



High-Performance Power Tools & Equipment

ELECTRIC • PNEUMATIC
HYDRAULIC • GAS • BATTERY

...the power of innovation!®

Metalworking Tools & Equipment

for Fabricating, Finishing, & Cutting



Magnetic Drills

Annular Cutters & Cutting Tools

Portable Saws

Surface Finishing

Flap Discs

Drills & Drive Units

Surface Preparation

Wet/Dry Industrial Vacuums

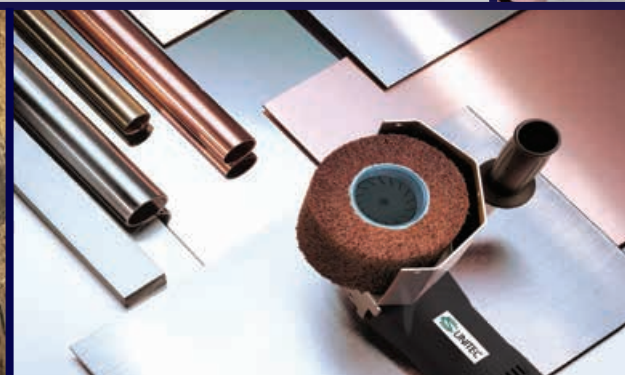



Trelawny™ Surface Preparation Equipment and Dust Collection Vacuums

p. 4-21

Deck Hammers, Scaling Hammers

p. 6-7

Heavy-Duty Needle/Chisel Scalars, incl. Low-Vibration & ATEX models

p. 8-14

Needles

p. 14

Long-Reach Chisels/Scrapers/Scalers

p. 15

Floor Scarifiers

p. 16-17

Hand-Held Scarifiers

p. 18

Deck Descalers

p. 19

Dust Collection Vacuums

p. 21



Magnetic Drills, Annular Cutters, Drills & Drive Units and Bevelers

p. 22-81

MABasic Portable Magnetic Drills

p. 26-29

Portable Magnetic Drills up to 2" dia.

p. 26-35

Pipe-Mount Magnetic Drills

p. 36-38

NEW Battery Powered eMAB450

p. 39

Portable Magnetic Drills from 2-1/16" to 3-1/8" dia.

p. 40-47

Portable Magnetic Drills from 4-1/16" to 5-1/8" dia.

p. 48-53

Pneumatic Portable Magnetic Drill

p. 54

Hydraulic Portable Magnetic Drills

p. 55-56

Underwater Tools

p. 57-59

Annular Cutters (including one-touch and rail cutters)

p. 60-68

Carbide-Tipped Hole Saws

p. 69

Mag Drill Accessories

p. 70-75

Electric Drills and Drive Units

p. 76-77

Pneumatic Drills and Drive Units

p. 78

Corner Drills and Drives

p. 79

SDS Rotary Hammer Drills

p. 80

Pneumatic Woodboring Air Drills

p. 81

Nut Runners

p. 82

Special Tools and Information

SAFEWRENCH® Safe Striking Wrench

p. 19

Tools for Hot Work Zones

p. 20

Underwater Tools

p. 57-58

ATEX Directive

p. 83



UNITEC Metalworking Tools

Surface Finishing Tools and Accessories

p. 84-109

| | |
|--|------------|
| PTX Eco Smart Linear Grinding System and Kits | p. 86-88 |
| PTX Abrasives and Accessories | p. 89-93 |
| VARILEX® Speed-Controlled Surface Finishing/Blending Tool | p. 94-95 |
| Flap Discs PLANTEX ™ | p. 96-97 |
| FIX Hook & Loop Abrasives & Systems | p. 98-99 |
| Poly-Magic Unitized Wheels | p. 100 |
| Fleece Discs | p. 100-101 |
| Cleaning Discs | p. 101 |
| PIPE-MAX Pipe Belt Grinder | p. 102 |
| King-BOA Round Tubing Sander | p. 103-104 |
| Gladius®1800 Multifunctional Grinder | p. 104 |
| Abrasives & Accessories for PIPE-MAX, King-BOA, & Gladius® | p. 105 |
| ROLEI® Deburring Machines | p. 106-107 |
| Portable Beveling Machines | p. 108-109 |

Saws, Pipe Cutting Machines and Accessories

p. 110-123

| | |
|--|------------|
| Dry Cutting Circular Saws | p. 110-111 |
| Portable Reciprocating Saws & Accessories | p. 112-113 |
| Portable Band Saws & Accessories | p. 114-115 |
| Power Hacksaws & Accessories | p. 116-118 |
| Pipe Cutting Machines | p. 119-121 |
| Electric Nibblers | p. 122 |
| Air Tool Accessories & Hydraulic Power Units | p. 123 |



METALWORKING TOOL INDEX



Safety Guidelines

Use all products according to the safety regulations of OSHA and directives by ANSI (American National Safety Institute) B7.1, European DIN EN 13743 and all other applicable international safety standards.



UNITEC Tool Index

SURFACE PREPARATION INDEX

Abrasives & Accessories for PIPE-MAX, King-BOA, & Gladius®.....p. 105

Air Tool Accessories & Hydraulic Power Units.....p. 123

Annular Cutters (including one-touch and rail cutters).....p. 58-68

Battery Powered Magnetic Drill.....p. 39

Carbide-Tipped Hole Saws.....p. 69

Cleaning Discs.....p. 101

Corner Drills and Drives.....p. 79

Deck Descalers.....p. 19

Deck Hammers, Scaling Hammers.....p. 6-7

Dry Cutting Circular Saws.....p. 110-111

Dust Collection Vacuums.....p. 21

Electric Drills and Drive Units.....p. 76-77

Electric Nibblers.....p. 122

FIX Hook & Loop Abrasives & Systems.....p. 98-99

Flap Discs.....p. 96-97

Fleece Discs.....p. 100-101

Floor Scarifiers.....p. 16-17

Gladius®1800 Multifunctional Grinder.....p. 104

Hand-Held Scarifiers.....p. 18

Hydraulic Portable Magnetic Drills.....p. 55-56

King-BOA Round Tubing Sander.....p. 103-104

Long-Reach Chisels/Scrapers/Scalers.....p. 15

MABasic Portable Magnetic Drills.....p. 26-29

Mag Drill Accessories.....p. 70-75

Magnetic Drills, Annular Cutters, Drills & Drive Units and Bevelers.....p. 22-81

Needle/Chisel Scalers, incl. Low-Vibration & ATEX models.....p. 8-14

Needle Scaler Needles.....p. 14

Nut Runners.....p. 82

Pipe Cutting Machines.....p. 119-121

PIPE-MAX Pipe Belt Grinder.....p. 102

Pipe-Mount Magnetic Drills.....p. 36-38

Pneumatic Drills and Drive Units.....p. 78

Pneumatic Portable Magnetic Drill.....p. 54

Pneumatic Woodboring Air Drills.....p. 81

Poly-Magic Unitized Wheels.....p. 100

Portable Band Saws & Accessories.....p. 114-115

Portable Beveling Machines.....p. 108-109

Portable Magnetic Drills from 2-1/16" to 3-1/8" dia.....p. 40-47

Portable Magnetic Drills from 4-1/16" to 5-1/8" dia.....p. 48-53

Portable Magnetic Drills up to 2" dia.....p. 26-35

Portable Reciprocating Saws & Accessories.....p. 112-113

Power Hacksaws & Accessories.....p. 116-118

PTX Abrasives and Accessories.....p. 89-93

PTX Eco Smart Linear Grinding System and Kits.....p. 86-88

ROLEI® Deburring Machines.....p. 106-107

Saws, Pipe Cutting Machines and Accessories.....p. 110-123

SDS Rotary Hammer Drills.....p. 80

Surface Finishing Tools and Accessories.....p. 84-109

Trelawny™ Surface Preparation Equipment and Dust Collection Vacuums.....p. 4-21

Underwater Tools.....p. 57-59

VARILEX® Speed-Controlled Surface Finishing/Blending Tool.....p. 94-95



New & Exclusive

BATTERY POWERED TOOLS



p.16



p.94



p.103



p.87



p.39



p.110



Surface Prep • Surface Finish • Cut • Drill

SF11 Steel Deck Hammer



11 heads deliver 33,000 BPM
Fracture and reduce scale, corrosion and thick coatings in minutes – and reduce blast media costs

CS Unitec's Trelawny™ ScaleForce Eleven Pneumatic Deck Hammer will fracture and reduce scale, corrosion and thick coatings in minutes. The machine's low profile body and adjustable handle mean the deck hammer needs only 6" clearance for working under pipes and other constructions.

- Includes Vibro-Lo™ vibration reduction technology
- Optional ATEX model beryllium copper replacement heads to reduce risk of explosion in potentially hazardous areas
- Replaceable taper fit cutter head reduces cost of replacement and extends piston life
- Vacuum shroud reduces hazardous and nuisance dust when used with dust collectors



11 heads provide 33,000 BPM (11 x 3000 BPM)



Applications Include:

- Ship Decks
- Tank Tops
- Bridge Decks
- Floating Platforms

CS Unitec's Trelawny™ ScaleForce Eleven Pneumatic Deck Hammer operates with 8x less vibration than standard models. This tool utilizes vibration damping components to offset the hammer vibration created when the heads impact the workpiece.

SF11 Accessories

| | Item ID: |
|---|----------|
| Cruciform Cutter Head | 426.5351 |
| Copper Beryllium (CuBe) Cruciform Cutter Head | 606.5303 |
| Bush Cutter Head | 426.5352 |
| Common Tapered Piston | 612.5301 |
| Vacuum Shroud | 437.0100 |



Bush

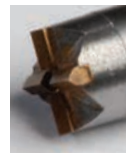

Cruciform



Copper Beryllium for use in potentially explosive areas



See page 21 for air-powered dust collection vacuum – ATEX classified for use in Gas Zone 2 and Dust Zone 22.

ScaleForce Eleven (SF11) Pneumatic Deck Hammer

| Item ID: | Motor Specifications | Cutting Width | Blows per Minute | Dimensions (WxH) | Noise Level dB(A) | Vibration Levels m/s ² | Weight (lbs.) |
|---|----------------------|---------------|------------------|------------------|-------------------|-----------------------------------|---------------|
| SF11 with Cruciform Heads and Dust Shroud | | | | | | | |
| 159.5910 | 70 CFM @ 90 PSI | 10" | 33,000 | 11.1" x 47.6" | 113.1 | 5.76 | 83 |
| SF11 (with ATEX certification) Copper Beryllium (CuBe) Heads | | | | | | | |
| 159.5930 | 70 CFM @ 90 PSI | 10" | 33,000 | 11.1" x 47.6" | 113.1 | 5.76 | 83 |

Pneumatic Hand-Held Scaling Hammers



Remove thick scale, heavy corrosion and hard coatings

CS Unitec's Trelawny™ line of pneumatic hand-held scaling hammers are ideal tools for the removal of thick scale, heavy corrosion and hard coatings. Areas of application include pipes, ship decks, oil platforms, storage tanks and bridge structures.

- Single-head scaling hammer includes Vibro-Lo™ vibration reduction technology
- Optional spark-resistant copper beryllium replacement heads reduce risk of explosion in potentially hazardous areas
- Detachable taper fit cutter head reduces cost of replacement and extends piston life

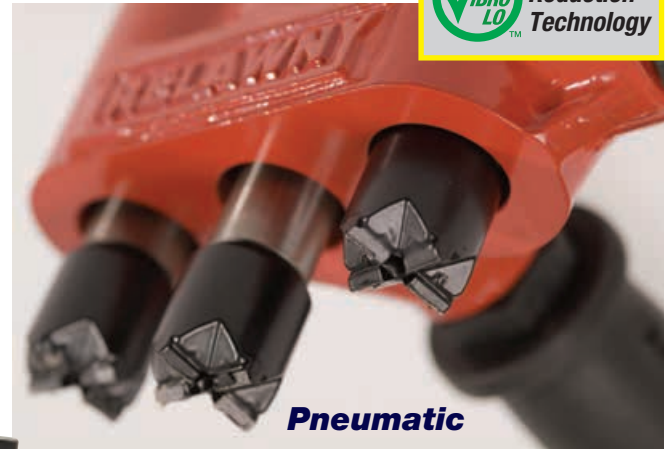







Applications Include:

- Pipes • Ship Decks • Oil Platforms
- Storage Tanks • Bridge Structures
- Gas / Utility Contractors



Pneumatic Hand-Held Scaling Hammers

- Air consumption @ 90 PSI – Single Head: 7 CFM; Triple Head: 11 CFM
- Noise level – 88.1 dB(A) to 92.7 dB(A)
- Hose Connection 3/8" NPT

| Description | Item ID: | Handle Type | Dimensions (LxH) | Vibration Levels (m/s ²) | Weight (lbs.) |
|---|----------|-------------|------------------|--------------------------------------|---------------|
| SF1 Single Head – 3000 Blows per minute | | | | | |
| TCT Cruciform Head | 151.5100 | Long | 19" x 6" | 6.8 | 5 |
| TCT Bush Head | 151.5105 | Long | 19" x 6" | 6.8 | 5 |
| VLSF1 Low-Vibration Single Head – 3000 Blows per minute | | | | | |
| TCT Cruciform Head  | 196.5095 | Long | 19" x 5.5" | 3.7 | 5 |
| CuBe Cruciform Head    | 196.5110 | Long | 19" x 5.5" | 3.7 | 5 |
| TCT Cruciform Head  | 196.5005 | Short | 9.25" x 6" | 6.8 | 4.5 |
| SF3 Triple Head – 9000 Blows per minute | | | | | |
| TCT Cruciform Head | 153.5300 | Long | 19" x 6" | 13.4 | 8 |
| TCT Bush Head | 153.5305 | Long | 19" x 6" | 13.4 | 8 |
| TCT Cruciform Head | 199.5350 | Short | 9.25" x 6" | 13.4 | 7 |
| CuBe Cruciform Head   | 153.5310 | Long | 19" x 6" | 13.4 | 8 |





CS Unitec's Trelawny™ Single-Head Hand-Held scaler operates with 8x less vibration than standard models. This tool utilizes vibration damping components to offset the hammer vibration created when the head impacts the workpiece.

Service kits available. Visit our website for more information.



Hand-Held Scaling Hammer Accessories

| | Item ID: |
|--|----------|
| TCT Cruciform Cutter Head | 426.5351 |
| Copper Beryllium (CuBe) Cruciform Cutter Head   | 606.5303 |
| TCT Bush Cutter Head | 426.5352 |
| Common Tapered Piston | 612.5301 |
| Single-Piece Steel Piston with Cruciform Head | 612.5305 |



SCAN TO SEE FULL PRODUCT DETAILS

Heavy-Duty Needle Scalers

Heavy-Duty Needle Scalers

Ideal for cleaning and stress-relieving weld seams and joints; texturing concrete; removing coatings, corrosion and other accumulated materials.

Power & Productivity

- Oversized piston with longer stroke
- Heavy-duty hardened anvil
- High-strength, long-lasting chisel-tipped needles

Low Maintenance & Less Downtime

- Air-powered – fewer moving parts
- Converts to chisel scaler in seconds
- Piston valve

Versatile

- One tool for different applications
- Lightweight – easy to handle



1B

Inline Grip



2B



2BPG

Pistol Grip



3BPG



2B Combination Kit

See next page for more information.

| Grip | Description | Item ID: | Needle Qty (3 mm) | Weight (lbs.) | Blows per minute | CFM @ 90 PSI | Noise Level dB(A) | Vibration Levels m/s ² |
|--------|--------------------|----------|-------------------|---------------|------------------|--------------|-------------------|-----------------------------------|
| Inline | 1B Needle Scaler | 111.1099 | 12 | 3.5 | 3800 | 3 | 110.4 | 8.5 |
| | 2B Needle Scaler | 121.2099 | 19 | 5.75 | 3000 | 5.5 | 113.3 | 9.3 |
| Pistol | 2BPG Needle Scaler | 123.2199 | 19 | 5.75 | 3000 | 5.5 | 113.3 | 12.6 |
| | 3BPG Needle Scaler | 133.3199 | 28 | 8.25 | 2200 | 8.0 | 114.5 | 18.9 |

Service kits available. Visit our website for more information.



Dust Collection Shroud for Standard Needle Scalers

Optional Dust Shroud for Needle Scalers – for use with dust extraction vacuums.
 Model 2B and 2BPG Needle Scalers – Order Dust Shroud Item ID: 418.2200
 Model 3BPG Needle Scaler – Order Dust Shroud Item ID: 418.3040



Scan to Learn More

Needle options – see page 14 for the following types of needles:

| Chisel | Flat | Pointed | Copper Beryllium | Stainless Steel |
|-----------------------|--------------------------------------|-----------------|--|--|
| light surface marking | light treatment and polishing effect | very hard scale | use in potentially explosive areas  | use in applications where corrosion or humidity is a problem, such as the food processing industry |

TVS™ Needle Scalers with Integrated Vacuum Shroud



Grip

Description

Item ID:

Weight (lbs.)

Blows per minute

CFM @ 90 PSI

Noise Level dB(A)

Vibration Levels m/s²

| | | | | | | | |
|--------|--------------------|----------|-----|------|-----|-------|------|
| Inline | 2B Needle Scaler | 139.2007 | 6.4 | 3000 | 5.5 | 98.6 | 17.4 |
| Pistol | 2BPG Needle Scaler | 139.2107 | 6.6 | 3000 | 5.5 | 98.6 | 22.4 |
| | 3BPG Needle Scaler | 139.3107 | 9.9 | 2200 | 8 | 105.1 | 19.9 |

Service kits available. Visit our website for more information.



Heavy-Duty Chisel Scalars

Ideal for splitting, chipping, pointing, brick raking and removing accumulated materials and corrosion.

- Inline, pistol and semi-pistol grip
- Ball bearing chisel retainer



Inline Grip



1B



2B

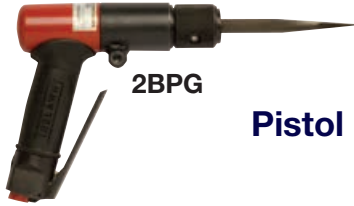

2BPG

Pistol Grip



3BPG

| Grip | Description | Item ID: | Weight (lbs.) | Blows per minute | CFM @ 90 PSI | Noise Level dB(A) | Vibration Levels m/s ² |
|--------|---------------------|----------|---------------|------------------|--------------|-------------------|-----------------------------------|
| Inline | 1B Chisel Scaler | 114.1200 | 3.3 | 3800 | 3 | 98.9 | 8.2 |
| | 2B Chisel Scaler | 124.2200 | 4.4 | 3000 | 5.5 | 98.6 | 17.4 |
| Pistol | 2BPG Chisel Scaler | 125.2300 | 4.5 | 3000 | 5.5 | 98.6 | 22.4 |
| | 3BPG Chisel Scaler | 135.3300 | 6.2 | 2200 | 8 | 105.1 | 25.6 |
| | 3BPG Chisel Scaler* | 135.3395 | 6.2 | 2200 | 8 | 105.1 | 25.6 |



Scan to Learn More

* 3BPG Chisel Scaler 135.3395 has 5/8" hexagonal chisel holder and is compatible with chisels shown on page 15. All others Chisel Scalars shown above have 1/2" square shank. Service kits available. Visit our website for more information.



2B & 2BPG Combination Kits



Inline Kit includes 2B Needle Scaler, 19 (3mm) needles, 3/4" width chisel and allen wrench. Item ID: 199.3120 (shown)

Pistol Grip Kit includes 2BPG Needle Scaler, 19 (3mm) needles, 3/4" width chisel and allen wrench. Item ID: 199.3121



Chisels for Standard Chisel Scalars

1/2" Square Shank

| Chisel Item ID: | Shank | Length | Width | Application |
|-----------------|--------------------|--------|------------|---|
| 704.1110 | Square | 7" | 2" | Spark-resistant Aluminum Bronze   for use in hazardous areas |
| 704.2105 | Square Cranked End | 7" | 1-3/8" | Weld flux and thick coating removal |
| 704.1101 | Square | 7" | 3/4" | Weld splatter removal |
| 704.1103 | Square | 7" | 2-1/2" | Wide flat chisel for the removal of rust or peeling paint |
| 704.1107 | Square | 10" | 3/4" | Flat chisel for weld splatter and sand cast cleaning |
| 704.1106 | Square | 8" | 1/4" | Mortar removal for repointing brick work |
| 704.1112 | Square | 7" | Moil Point | Concrete chipping |

CS Unitec offers a full line of non-sparking, non-magnetic chisels and safety hand tools for hazardous areas and Ex zones. Contact us for details.

Standard Needle Scalars and Chisel Scalars convert in seconds with optional head or when purchased as a Kit. Contact us for more information.



Low-Vibration Needle/Chisel Scalars



High power with low vibration – 8x less than standard models

CS Unitec's Trelawny™ line of Low-Vibration needle/chisel scalars offer high performance and low vibration for greater productivity and improved operator comfort. Ergonomically designed with low maintenance and quick change tooling option.

- Integrated Vibro-Lo™ vibration reduction technology
- Lightweight, easy to handle
- Optional dust shroud for dust and debris collection
- Tool-free needle changeover
- Converts to chisel scaler in seconds



CS Unitec's Trelawny™ Vibro-Lo™ line of Needle/Chisel Scalars operate with 8x less vibration than standard models. These tools utilize vibration damping components to offset the hammer vibration created when the needles/chisels impact the workpiece.



Dust Collection Shroud



VL223



VL203

VL303



Scan To Learn More

ATEX-Certified Needle Scalars available for hazardous environments and Ex Zones. See page 13 for details.

Needle Scalars and Chisel Scalars convert in seconds with optional head or when purchased as a Kit. See page 12 for Kit information.



Applications include:

- Cleaning and stress-relieving weld seams and joints
- Removing coatings, corrosion and other accumulated materials
- Texturing concrete
- Splitting, chipping, pointing and brick raking

Heavy-Duty Low-Vibration Needle Scalers



Heavy-Duty Vibro-Lo™ Needle Scalers

- Inline or pistol grip
- Remove coatings, corrosion and other accumulated materials
- Ideal for stress-relieving weld seams and joints



Needle Scalers and Chisel Scalers convert in seconds with optional head or when purchased as a Kit. See page 12 for Kit information.

| Grip | Description | Item ID: | Needle Qty (3 mm) | Weight (lbs.) | Blows per minute | CFM @ 90 PSI | Noise Level dB(A) | Vibration Levels m/s ² |
|--------|------------------------------------|-----------------|-------------------|---------------|------------------|--------------|-------------------|-----------------------------------|
| Inline | VL223 Needle Scaler | 199.2103 | 19 | 5.25 | 2400 | 4 | 90.7 | 2.56 |
| | VL223 Needle Scaler w/ dust shroud | 199.2313 | 19 | 5.25 | 2400 | 4 | 90.7 | 2.56 |
| Pistol | VL203 Needle Scaler | 199.2003 | 19 | 6 | 2400 | 4 | 90.7 | 2.75 |
| | VL203 Needle Scaler w/ Dust Shroud | 199.2303 | 19 | 6 | 2400 | 4 | 90.7 | 2.75 |
| | VL303 Needle Scaler | 199.3003 | 28 | 7.75 | 3000 | 5.5 | 109.5 | 2.30 |
| | VL303 Needle Scaler w/ Dust Shroud | 199.3005 | 28 | 7.75 | 3000 | 5.5 | 109.5 | 2.30 |

* Dust shroud and flat, corner and edge cuff included | Service kits available. Visit our website for more information.

Needle options – see page 14 for the following types of needles:

| Chisel | Flat | Pointed | Copper Beryllium | Stainless Steel |
|-----------------------|--------------------------------------|-----------------|------------------------------------|--|
| light surface marking | light treatment and polishing effect | very hard scale | use in potentially explosive areas | use in applications where corrosion or humidity is a problem, such as the food processing industry |

Dust Collection Shroud for Vibro-Lo™ Needle Scalers



Optional Dust Shroud for Needle Scalers – for use with dust extraction vacuums and flat cuff only.

VL223 / VL203 Needle Scaler – Dust Shroud Item ID: 418.2003

VL303 Needle Scaler – Dust Shroud Item ID: 418.3003

See page 21 for dust extraction systems.

Drop Protection Kit

CS Unitec offers a drop protection kit for our Vibro-Lo™ Needle/ Chisel Scalers. Protect your investment when working at heights or in applications where dropping/ losing the tool is likely, including: offshore platforms and rigs, bridges/ scaffolding, vessels and ships.

VL223 and VL203
Order Item ID: 720.2003*

VL303
Order Item ID: 720.3003*

* Safety clip and line not supplied



Heavy-Duty Low-Vibration Chisel Scalers

Equipped with Vibro-Lo™ low vibration technology for 8x less vibration than standard models



LOW-VIBRATION CHISEL SCALERS



| Grip | Description | Item ID: | Weight (lbs.) | Blows per minute | CFM @ 90 PSI | Noise Level dB(A) | Vibration Levels m/s ² |
|--------|---------------------|-----------------|---------------|------------------|--------------|-------------------|-----------------------------------|
| Inline | VL223 Chisel Scaler | 199.2213 | 6.5 | 2400 | 4 | 76.3 | 3.69 |
| Pistol | VL203 Chisel Scaler | 199.2203 | 7 | 2400 | 4 | 76.3 | 3.33 |
| | VL303 Chisel Scaler | 199.3203 | 9.5 | 3000 | 5.5 | 78.2 | 3.7 |



Service kits available. Visit our website for more information.

Chisels for Vibro-Lo™ Chisel Scalers

Scan To Learn More



| Chisel Item ID | Shank | Length | Width | Application |
|----------------|--------------------|--------|--------|--|
| 704.3110 | Square | 7" | 2" | Spark resistant Aluminum Bronze for use in hazardous areas |
| 704.3205 | Square Cranked End | 7" | 1-3/8" | Weld flux and thick coating removal |
| 704.3101 | Square | 7" | 3/4" | Weld splatter removal |
| 704.3103 | Square | 7" | 2-1/2" | Wide flat chisel for the removal of rust or peeling paint |
| 704.3107 | Square | 10" | 3/4" | Flat chisel for weld splatter and sand cast cleaning |

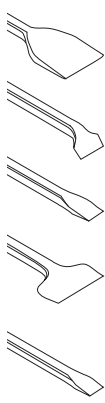

Ex **H** CS Unitec offers a full line of non-sparking, non-magnetic chisels and safety hand tools for hazardous areas and Ex zones. Contact us for details.



Vibro-Lo™ Needle/ Chisel Scaler Kits

CS Unitec offers Vibro-Lo™ Needle/Chisel Scaler Kits, each supplied with the Needle Scaler, 3mm needles, a chisel holder, anvil and a 3/4" blade chisel.

- VL223 Kit** – Order Item ID: 199.2113
- VL203 Kit** – Order Item ID: 199.2105
- VL303 Kit** – Order Item ID: 199.3103

VL223 Kit and VL303 Kit do not include a plastic carrying case.

ATEX-Certified Needle/Chisel Scalers



Specially-designed for use in hazardous environments – equipped with Vibro-Lo™ low vibration technology

These specially engineered Trelawny VL203Ex, VL223Ex and VL303Ex needle scalers are:

- Fully certified to the classification: EX II 2G Ex h IIB T6 Gb & Ex II 2 D Ex h IIIC T135 °C Db under the ATEX Directive 94/9/EC. Certified for use in Gas Zone 1 and Dust Zone 21.
- Ideal for use in Ex Zones, oil, gas & petrochemical industries such as refineries, offshore platforms, LPG terminals and all chemical processing environments.



ATEX Certified

For use in hazardous environments and ATEX and Ex Zones



VL223Ex



VL203Ex



VL303Ex

| | Grip | Description | Item ID: | Needle Qty (3 mm) | Weight (lbs.) | Blows per minute | CFM @ 90 PSI | Vibration Levels m/s ² |
|--|--------|--|-----------------|-------------------|---------------|------------------|--------------|-----------------------------------|
| | Inline | VL223Ex Needle Scaler with dust shroud | 196.2107 | 19 | 5.25 | 2400 | 4 | 2.56 |
| | Pistol | VL203Ex Needle Scaler with dust shroud | 196.2207 | 19 | 6 | 2400 | 4 | 2.75 |
| | | VL303Ex Needle Scaler with dust shroud | 196.3007 | 28 | 7.75 | 3000 | 5 | 2.3 |

3mm Copper Beryllium needles included. Service kits available: For VL223/VL203EX Item ID: 446.2003X, For VL303EX Item ID: 446.3003X

| | Grip | Description | Item ID: | Weight (lbs.) | Blows per minute | CFM @ 90 PSI | Vibration Levels m/s ² |
|--|--------|-----------------------|-----------------|---------------|------------------|--------------|-----------------------------------|
| | Inline | VL223Ex Chisel Scaler | 196.2117 | 6.5 | 2400 | 4 | 3.33 |
| | Pistol | VL203Ex Chisel Scaler | 196.2217 | 7 | 2400 | 4 | 3.69 |
| | | VL303Ex Chisel Scaler | 196.3017 | 9.5 | 3000 | 5 | 3.7 |

Service kits available. 2" wide flat Copper Beryllium chisel included. For VL223/VL203EX Item ID: 446.2003X, For VL303EX Item ID: 446.3003X

Standard Features



Copper Beryllium needles – high strength with non-sparking and non-magnetic properties. **For all Needles see pg. 14**



Dust shroud to protect user from hazardous dust and debris. Flat, corner, and edge ciff included.
VL223 / VL203: 418.2003
VL303: 418.3003



Fall arrestor eliminates the risk of dropping the tool causing injury or equipment damage
VL223 / VL203: 720.2003
VL303: 720.3003



Optional Accessory

Anti-static lanyard available for use with the fall arrestor (Item ID: 415.3003)



Safety Hand Tools LIFETIME WARRANTY



CS Unitec offers over 3000 safety hand tools for use in Ex Zones, ATEX Zones and hazardous environments where hazardous, flammable or combustible vapors, liquids, dusts or residues may be present. **Contact us for more information!**

Needles for Needle Scalers

CS Unitec's Trelawny™ needles last 10x longer than standard needles. Save time and money with fewer needle changes and less downtime.

All of CS Unitec's Needle Scalers are delivered from stock complete with 7" (180mm) long x 3mm diameter high performance needles. Other needle holders are available as accessories for use with 2mm and 4mm diameter needles.

We also offer spark resistant needles for use in potentially hazardous areas and Ex zones, as well as stainless steel needles for use in humid areas – such as applications in the food processing industry – where corrosion is a concern.



Chisel Tip

These needles will clean the same materials as a pointed tip, but will leave light surface marking



| Size | Description | Item ID |
|------|---------------------|----------|
| 3mm | Set of 19 needles | 403.2119 |
| 3mm | Box of 100 needles | 453.2110 |
| 3mm | Box of 1000 needles | 443.2107 |

Pointed Tip

Sharpened to a conical point, these are the most effective in breaking through very hard scale on materials where some surface indentation is permissible – or where a roughening or keying of the surface is actually desirable.



| Size | Description | Item ID |
|------|---------------------|----------|
| 3mm | Box of 100 needles | 453.3110 |
| 3mm | Box of 1000 needles | 443.3107 |

Flat Tip

Flat-tipped needles will reduce marking on metal surfaces and can give a polishing effect. For use on thin gauge metals and any surface where a light treatment is required.



2mm needles used on a welded joint produce a similar effect to shot peening, reducing stress in the weld.

| Size | Description | Item ID |
|------|---------------------|----------|
| 3mm | Set of 19 needles | 403.1119 |
| 3mm | Box of 100 needles | 453.1110 |
| 3mm | Box of 1000 needles | 443.1107 |

Spark-Resistant Copper Beryllium

Available in 3mm flat tip only; for use in potentially hazardous areas.



| Size | Description | Item ID |
|------|--------------------|----------|
| 3mm | Set of 19 needles | 403.1319 |
| 3mm | Set of 28 needles | 403.1328 |
| 3mm | Box of 100 needles | 453.1310 |
| 3mm | Box of 500 needles | 443.1307 |



Stainless Steel

Available in 3mm flat tip only, to be used in applications such as refurbishment of food processing machinery or areas of high humidity where the corrosive effect on needles would be prohibitive.



Used on decorative concrete surfaces where contamination of the surface from carbon steel needles is undesirable.

| Size | Description | Item ID |
|------|--------------------|----------|
| 3mm | Box of 100 needles | 453.1207 |
| 3mm | Box of 500 needles | 443.1207 |



Conversions:
3mm = 0.12"
180mm = 7"

See page 21 for dust extraction solutions.

Long-Reach Chisels/Scrapers/Scalers

Chip, scrape and descale with one versatile tool

CS Unitec's Trelawny™ Long-Reach Scrapers feature one tool with multiple applications.

- Available in 2', 4', 5' and 6' lengths
- 3 tools in 1 – chipper, scraper and descaler
- Quick-change chisel release
- Low air consumption
- Standard and "LITE" models

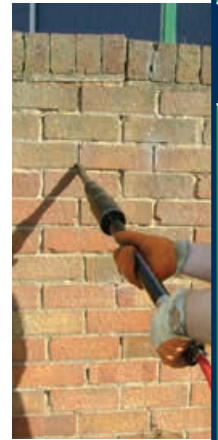

Applications include removal of:

- Ice
- Residue
- Adhesive
- Asbestos
- Linoleum
- Carpeting
- Plaster
- Mortar
- Floor tiles
- Metal slag
- Rubber coatings
- Roofing materials
- Chemical spillages
- Bituminous products



3 tools in 1:

Chipping A Scraping B Descaling C



Accessories sold separately.

Long-Reach Chisels/Scrapers

| Model | Description | Item ID: | Weight (lbs.) | Blows per minute | CFM @ 90 PSI | Noise Level dB(A) |
|-------------------|-------------|-----------------|---------------|------------------|--------------|-------------------|
| Standard Scrapers | 2ft. Chisel | 136.3299 | 8 | 2200 | 4.5 | 84 |
| | 4ft. Needle | 137.3400 | 11 | 2200 | 4.5 | 104 |
| | 4ft. Chisel | 136.3499 | 11 | 2200 | 4.5 | 84 |
| | 5ft. Chisel | 136.3599 | 12 | 2200 | 4.5 | 86 |
| LITE Scrapers | 4ft. Chisel | 136.3497 | 6.75 | 2200 | 4.5 | 89 |
| | 5ft. Chisel | 136.3597 | 7.5 | 2200 | 4.5 | 89 |
| | 6ft. Chisel | 136.3697 | 8.5 | 2200 | 4.5 | 84 |

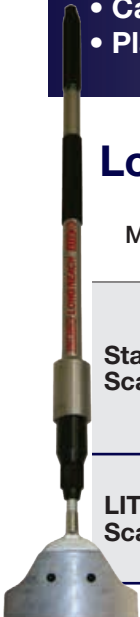

A: Chisel Accessories - 5/8" hex

| Chisel Item ID: | Chisel Length | Blade Width | Applications |
|-----------------|---------------|--------------------|--|
| 705.1100 | 9" | 2" | Spark-resistant aluminum bronze for use in hazardous areas |
| 705.1101 | 9" | 1" | Flat chisel for sand cast chipping |
| 705.1102 | 8" | 4" | Asphalt cutter/paint removal/general chipping applications |
| 705.1106 | 9" | 2" | Removal of linoleum from floor base |
| 705.1112 | 8" | 4" | Spark-resistant aluminum bronze for use in hazardous areas |
| 705.2102 | 8" | 4" | Floor tile removal |
| 708.1101 | 1" | 1-1/8" comb insert | Brick cleaning and reclamation (use with 8" long comb holder 708.1100) |



B: Scraper Accessories

(Assembly includes holder and 1 blade)

| Assembly Item ID: | Blade Pack | Blade Width | Applications |
|-------------------|---------------------|-------------|-------------------------------------|
| Flat | | | |
| 431.3504 | 439.3504 (5 Blades) | 4" | Adhesive and paint build up removal |
| 431.3508 | 439.3508 (5 Blades) | 8" | Paint and coating spillage removal |
| 431.3512 | 439.3512 (4 Blades) | 12" | Carpet and tile removal |
| Beveled | | | |
| 431.3904 | 439.3524 (5 Blades) | 4" | Stubborn adhesive removal |
| 431.3908 | 439.3528 (5 Blades) | 8" | Carpet and tile removal |
| 431.3912 | 439.3522 (4 Blades) | 12" | Adhesive removal |



C: Needle Scaler Accessories

All long-reach scrapers are available as needle scalers by changing the scraper/chisel with the needle attachment Item ID: 415.3532. See page 14 for needles.

Floor Scarifiers Electric • Pneumatic • Gas • Battery

Remove rust, scale, paint, adhesives and more from steel and concrete

Mounted Drum & TCT Cutter Set Included

CS Unitec's Trelawny™ Floor Scarifiers tackle the most demanding surface preparation and material removal applications. Ideal for the removal of coatings and corrosion from steel and concrete surfaces to prepare for re-coating. Produce an ideal keyed or grooved profile on concrete for waterproofing and non-slip surface applications.

- Depth control maximizes performance and extends cutter life
- Integrated vacuum connection and hold-to-run button
- Electric, Pneumatic, Gas, or Battery power



FLOOR SCARIFIERS

Applications include:

- Removal of rust, scale, paint, adhesives and more
- Keyed or grooved profiles
- Roughing concrete

Innovative Product Award Winner 2026

TFP 200 Battery

NEW



TFP 200 Electric

TFP 200 Pneumatic

TFP 200 Gas

| TFP 200 Cutters | Individual Cutter | Cutters/Spacers Required Per Drum | Drum Assembly |
|--|----------------------|-----------------------------------|---------------|
| Wire Brushes | N/A | N/A | 320.9620 |
| Beam Cutters | 320.5120 | 264 Pieces | 320.1020SB |
| Star Cutters | 320.3658 | 208 Pieces | 320.1020SS |
| TCT Cutters and Spacers | 320.5500 320.4140 | 80 Pieces 88 Pieces | 320.1020ST |
| Milling Cutters (22mm) | 320.5600 | 24 Pieces | 320.1020SM |
| TCT Cutters (for grooving) and Spacers | 320.5500 320.4140 | 20 Pieces 196 Pieces | 320.1020G |

Cutter Applications:

Wire Brushes are ideal for cleaning loose rust, flaking coatings, & cement deposits.

Beam Cutters are ideal for light paint/corrosion removal, with minimal damage to substrate.

Star Cutters are ideal for the removal of mastics and rubberized coatings.

Tungsten Carbide-Tipped (TCT) Cutters are ideal for aggressive applications such as roughing concrete and heavy corrosion removal, as well as grooving roadways for non-slip surface.

Milling Cutters are ideal for the removal of plastic road markings without penetrating the surface.



Scan To Learn More

TFP 200 Floor Scarifiers

Every TFP 200 machine includes mounted drum and TCT cutter set

| Item ID: | Motor Specifications | Max Cutting Depth per Pass | Cutting Width | Dimensions (WxLxH) | Weight (lbs.) |
|----------------------------|-------------------------------|----------------------------|---------------|--------------------|---------------|
| TFP 200 Electric | | | | | |
| 320.2342T | 120V, 50/60 Hz, 1Ph, 1.5 HP | 1/8" | 8" | 14" x 35" x 35" | 149 |
| 320.2404T | 230V, 50/60 Hz, 1Ph, 3 HP | 1/8" | 8" | 14" x 35" x 35" | 149 |
| TFP 200 Pneumatic | | | | | |
| 320.2412T | 165CFM @ 90 PSI, 3.5 HP | 1/8" | 8" | 14" x 35" x 35" | 99 |
| TFP 200 Gas | | | | | |
| 320.2400T | Honda GX160 Gas, 5.5 HP | 1/8" | 8" | 14" x 35" x 35" | 130 |
| NEW TFP 200 Battery | | | | | |
| 320.2520T | 2 x 8Ah Lithium-Ion Batteries | 1/8" | 8" | 14" x 35" x 35" | 128 |

For handheld scarifier models see page 18



Floor Scarifiers Gas • Electric

TFP 260 floor scarifier with 10" cutting width for medium to large jobs

Mounted Drum & TCT Cutter Set Included

Remove coatings and corrosion from steel and concrete surfaces to prepare for re-coating. Level and remove hard materials. Remove painted lines.

- Depth control maximizes performance and extends cutter life
- Integrated vacuum connection for dust-free operation
- Quick-lift drum lever for operator control
- Gas or electric power



| TFP 260 Cutters | Individual Cutter | Cutters/Spacers Required Per Drum | Drum Assembly |
|--|----------------------|-----------------------------------|---------------|
| Beam Cutters | 326.5120 | 332 Pieces | 326.1016DB |
| Star Cutters | 326.3658 | 342 Pieces | 326.1016DS |
| TCT Cutters and Spacers | 320.7009 320.4160 | 123 Pieces 129 Pieces | 326.1016ST |
| Milling Cutters (16mm) | 320.5680 | 60 Pieces | 326.1016DM |
| TCT Cutters (for grooving) and Spacers | 320.7009 320.4160 | 36 Pieces 224 Pieces | 326.1016GT |

TFP 260 Floor Scarifiers

Every TFP 260 machine includes a mounted drum and TCT cutter set

| Item ID: | Motor Specifications | Max Cutting Depth per Pass | Cutting Width | Dimensions (WxLxH) | Weight (lbs.) |
|-------------------------|---------------------------------|----------------------------|---------------|--------------------|---------------|
| TFP 260 Gas | | | | | |
| 326.2400T | Honda GX240 Gas, 8 HP | 1/4" | 10" | 17" x 44" x 45" | 408 |
| TFP 260 Electric | | | | | |
| 326.2406T | 415V, 50/60 Hz, 3-Phase, 7.5 HP | 1/4" | 10" | 17" x 44" x 45" | 408 |

Scan To Learn More



For handheld scarifier models, see page 18

Hand-Held Scarifiers - Rotopeen™ Air Powered

Peening Preparation Tool (PPT) – ideal alternative to small-area shot blasting

CS Unitec's Genuine Trelawny™ Rotopeen™ hand-held scarifiers are the ideal alternative to small-area shot blasting for cleaning and preparing steel and concrete surfaces. They utilize Rotopeen™ 'C' flaps to offer a captive shot method of surface preparation.



ROTOPEEN FLAP FINISH

- Integrated dust shroud for dust and debris collection, as well as cleaner, safer removal of lead-based paints and contaminated particles



Air Models
194.0405 and
194.C405,
4" cutting width

Applications include:

- Aggressive removal of alkyds, adhesives, lead-based paints, mastics, coatings, corrosion, anti-skid material & more
- Cleaning & preparing steel and concrete surfaces



See page 21 for dust extraction systems.

Hand-Held Scarifier Accessories

Star Cutter
Item ID: 312.S200
Aggressive removal of thick coatings

Beam Cutter
Item ID: 312.R200
Removal of hard coatings, less aggressive than star cutter

3M™ Rotopeen™ 'C' Flap
Item ID: 312.MRPC
Removal of paint and rust to bare metal finish
Produces SSPC 11 Finish

HEAVY SCALING

SURFACE PROFILING

| | Star Cutter | Beam Cutter | 3M™ Rotopeen™ 'C' Flap |
|----------------------|-------------------|------------------------------|-----------------------------------|
| Nuclear | — | — | Radioactive waste removal/capture |
| Ships decks | Non-slip coatings | — | General paint removal |
| Construction | Plaster removal | Ceiling / wall paint removal | Ceiling / wall paint removal |
| Factory Floors | — | Floor marking removal | Floor marking removal |
| Swimming Pools | Adhesive removal | Adhesive removal | — |
| Bridge Maintenance | Sealant removal | — | Paint / sealant removal |
| Pipeline Maintenance | — | — | Protective coating removal |



Star Cutter
Cutting Width Quantity Required
2" 80
4" 160



Beam Cutter
Cutting Width Quantity Required
2" 56
4" 112



Rotopeen™ 'C' Flap*
Cutting Width Quantity Required
2" 6
4" 12

* Set of 6 C FLAPS order Item ID: 312.MRPC-6

Pneumatic Hand-Held Scarifiers

| Item ID: | CFM @ 90 PSI | Speed (RPM) | Cutting Width | Cutting Media | Weight (lbs.) | Vibration Levels m/s ² |
|----------|--------------|-------------|---------------|---------------|---------------|-----------------------------------|
| 194.0205 | 30 | 2700 | 2" | 'C' Flaps | 7.5 | 3.5 |
| 194.C205 | 30 | 2700 | 2" | Star Cutters | 11.5 | 6 |
| 194.0405 | 30 | 2700 | 4" | 'C' Flaps | 9 | 3.1 |
| 194.C405 | 30 | 2700 | 4" | Star Cutters | 13.25 | 4.6 |

These models are compatible with Star Cutters, Beam Cutters and Rotopeen™ 'C' Flaps



Floor Models Available
See Pages 16 & 17



SCAN TO SEE FULL PRODUCT DETAILS

Deck Descalers

Rapidly remove scale, rust, paint and other unwanted deposits

CS Unitec's Trelawny™ Trident Neptune Deck Descaler is ideal for the rapid removal of scale, rust, paint and other unwanted deposits on ship decks and other metal surfaces, leaving a receptive surface for priming/painting or coating application.



- 9' x 5/8" flexible shaft for wide coverage area
- Unique non-corrosive D-coupling with positive locking mechanism
- Two-skid base design keeps unit stable and upright; optional swivel base available



Scan To Learn More

Trident Neptune Deck Descalers

| Item ID: | Motor Specifications | ISSA Number | IMPA Number | Cutter Speed (RPM) | Dimensions (LxWxH) |
|--------------------------------|----------------------|-------------|-------------|--------------------|---------------------|
| Electric with Skid Base | | | | | |
| 340.TN/S/110 | 110V / .75 HP | 55.077.00 | 59 12 41 | 2850 | 106" x 8.3" x 11.4" |
| 340.TN/S/220 | 220V / .75 HP | 55.077.00 | 59 12 42 | 3450 | 106" x 8.3" x 11.4" |

Standard equipment includes: 9' x 5/8" flexible shaft; heavy-duty leaf scaling head; 6-cutter scaling head; 6" dia. power brush, spanner set and hand guard.

SAFEWRENCH® SAFE Striking Wrench

Hands-free – secures itself in any position



Spring washers keep SAFEWRENCH secure on bolt and nut – even upside down
Can be used as a counter-wrench
Drop protection

Prevent Hand Injuries
Operate hammer with 2 hands



- Manufactured of CRV30 chrome vanadium steel
- Black coated surface for maximum rust protection



Metric

| Item ID: | Bolt Size |
|----------|-----------|
| SW-2024S | 24mm |
| SW-2027S | 27mm |
| SW-2030S | 30mm |
| SW-2032S | 32mm |
| SW-2036S | 36mm |
| SW-2041S | 41mm |
| SW-2046S | 46mm |
| SW-2050S | 50mm |
| SW-2055S | 55mm |
| SW-2060S | 60mm |
| SW-2065S | 65mm |
| SW-2070S | 70mm |
| SW-2075S | 75mm |

US Inch - Imperial

| Item ID: | Bolt Size |
|----------|-----------|
| SW-3031S | 1-1/4" |
| SW-3036S | 1-7/16" |
| SW-3041S | 1-5/8" |
| SW-3046S | 1-13/16" |
| SW-3050S | 2" |
| SW-3055S | 2-3/16" |
| SW-3060S | 2-3/8" |
| SW-3065S | 2-9/16" |
| SW-3070S | 2-3/4" |

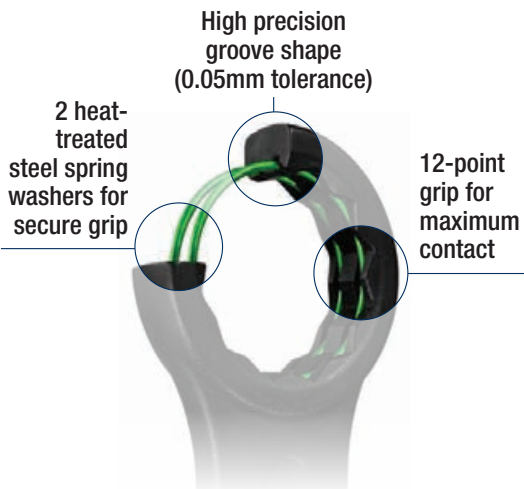

High precision groove shape (0.05mm tolerance)

2 heat-treated steel spring washers for secure grip

12-point grip for maximum contact

Tools for Hot Work – Ex Zones

CS Unitec's heavy-duty pneumatic and hydraulic power tools and non-sparking hand tools are specifically designed, manufactured and tested for use in hazardous areas and Ex Zones.



NEW RECIPROCATING SAWS

For cutting steel and pipe up to 6" dia.
See page 112-113

ATEX Certified
Air and Hydraulic Tools

See page 83 for ATEX details or visit
www.csunitec.com



Scan To
see all of our
ATEX tools



PORTABLE HACKSAWS

For on-site cutting of pipe up to 30" OD and structural steel
See page 116-118



SDS Plus and SDS Max ROTARY HAMMER DRILLS

See page 80



CIRCULAR SAWS

7-1/2", 9" & 12-5/8" dia., cut 90°
and 45° angles up to 4-3/4" deep
See page 110-111



PORTABLE BAND SAWS

Cut up to 9"
See page 114-115



MAGNETIC DRILLS

Air & Hydraulic

For drilling up to 4" dia. holes
See page 54 - 56



Explosion-proof
AXIAL FANS
12" to 24" diameter

ATEX IMPACT WRENCHES



Safety Tools – Non-Sparking, Non-Magnetic

- Lifetime Warranty
- Non-sparking, non-magnetic, & corrosion-resistant safety tools
- Aluminum Bronze (AlBr) or Copper Beryllium (CuBe) alloys
- For Ex and hot work zones where hazardous, flammable or combustible materials are present
- Hammers, wrenches, sockets, wedges, chisels and more
- Over 5000 different SKU's
- Produced in an ISO9001:2015 facility

TÜV Certified
*for explosive
atmospheres*



Scan for
Full-Line



For use in Ex and Hot Work Zones

Dust Collection Vacuums

Electric • Pneumatic



Dust Collection Vacuums with HEPA Filtration
For use Wet & Dry



| Specifications | Powerhouse Basic | Powerhouse TOP | Powerhouse XL | The Ultimate |
|-----------------------|------------------------------|----------------|---------------|--------------|
| Item ID | 103860 | 103464 | 103761 | 103365 |
| Power (Amp) | 13 | 13 | 13 | 13 |
| Volume | 6.6 (gal) | 6.6 (gal) | 13.2 (gal) | 9.2 (gal) |
| Sound Level | 69 (dB(A)) | 69 (dB(A)) | 69 (dB(A)) | 69 (dB(A)) |
| Filter Bag | 1x Fleece (Item ID: 468495) | | | |
| Weight | 26.9 (lbs) | 26.9 (lbs) | 40.3 (lbs) | 37 (lbs) |
| Cable Length | 26.2 (ft) | 26.2 (ft) | 26.2 (ft) | 26.2 (ft) |
| Max. Reach | 42.6 (ft) | 42.6 (ft) | 42.6 (ft) | 42.6 (ft) |
| CFM | 157 | 157 | 157 | 157 |
| Filtration Efficiency | HEPA: 99.995% to .03 Microns | | | |



Dustfixx Pre-Separator
(Item ID: 103402) - Catch large quantities of dust before reaching the main filter to extend filter life



Starbox (Item ID: 468518)
For convenient carrying of vacuum accessories



Wide range of accessories, including but not limited to: vacuum hoses, nozzles, filters, filter bags, & more

To Learn More about our Dust Collection Vacuums, Scan Here:
Air-Powered Dust Collection Vacuum – KAV 30 AIR



- Antistatic vacuum and air supply hose
- ATEX classified Ex II 2 GcT6 for use in Gas Zone 2 and Dust Zone 22
- Robust stainless steel construction
- Floor tool kit for general cleaning work
- Double filtration with optional 14" Permaflow filter
- Optional HEPA filter – for collection of hazardous dust
- Disposable paper filter or cloth bag for wet use

KAV 30 AIR Vacuum Specifications

| | Dry Model 303.10KAV30/D | Wet/Dry Model 303.10KAV30/WD |
|--------------------------------|----------------------------|---------------------------------|
| CFM @ 90 PSI | 35 | 35 |
| Output flow | 70 CFM | 70 CFM |
| Tank capacity | 6.8 gal. | 6.8 gal. |
| Weight | 32 lbs. | 32 lbs. |
| Paper Filter Item ID: (10pk.) | 303.1030 | 303.1030 |
| HEPA Filter Item ID: | 303.1060 | 303.1060 |
| K4 Paper Bags Item ID: (10pk.) | 303.1005 | 303.1005 |
| Micro Fiber Bags (5 pk.) | 303.1003 | 303.1003 |

CS Unitec make no claim that use of a vacuum will eliminate contaminants. Wear an approved respirator mask and follow all appropriate OSHA safety regulations for proper ventilation, dust handling, eye protection, etc. when using a dust extraction grinder and vacuum.

Portable Magnetic Drilling Machines

Fast, accurate hole cutting... on the job site or in the shop!



Designed for continuous operation, CS Unitec's portable magnetic drills are ideal for drilling structural steel and virtually any metal. We offer the most compact, powerful and reliable series of portable magnetic drills for holes up to 6" diameter. All CS Unitec drills are heavy-duty for use in construction and industry. Our complete line includes electric, pneumatic and hydraulic tools. They are available for prompt delivery.

CS Unitec is the industry leader in:

- Power-to-weight ratios
- Strongest clamping force with high-density (HD) dual-coil magnets
- Magnetic drills for tapping
- Annular Cutters: TiAlN, HSS, cobalt steel and carbide-tipped

Our drills have unique features:

- Longest drills stroke in the industry
- Variable-speed, multiple-gear models
- Electric, pneumatic and hydraulic power
- Reversible motors for tapping
- Swivel base stand for hard-to-reach areas
- mm drill models for in place machining
- Patented pipe swivel base models



Rugged construction and sophisticated functionality.

Intuitive magnets, ergonomic controls and simple operation for superior cuts.

Overheating Protection with CoolMag

COOLMAG™ Electromagnets

ensure that the magnet does not overheat. When the magnet is switched on for long periods of time, the coils could overheat or even burn out. The CoolMag feature reduces the power of the magnets when the drill motor is not active. Therefore, it won't build up heat.

CS Unitec high-density dual-coil magnets are ground, not cast, and are wound into two circles to increase the surface area and density of the magnetic field.



Keyless, quick-change system for annular cutters saves time and money. Just twist and lock.



Twist Drilling



Tapping



Reaming



Countersinking

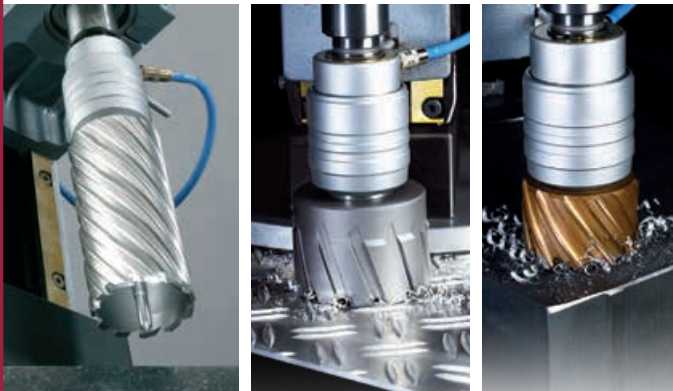

Custom machines for unique applications

Our engineers can create a drill, drill rig, or other application-specific arrangement to meet your needs.

For more information, or call 1-800-700-5919 for design assistance.

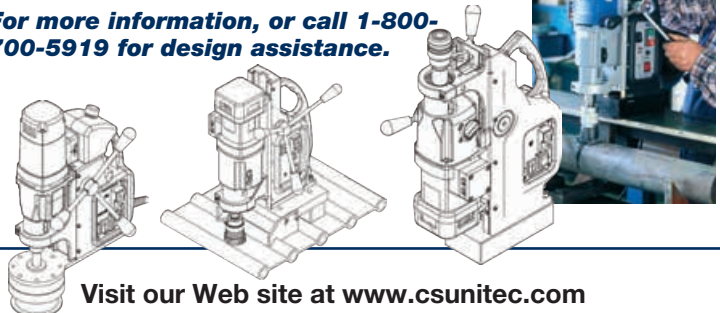

The value is in the engineering...
the payback is in the performance.



IQ Magnetic System for Active Safety

Magnetic force is the key to safety and success.

The magnetic force of your magnet depends on a number of factors:

- ▶ Thickness of material being drilled
- ▶ Coatings or paint layers on material
- ▶ Chips, dirt or grease between the magnet and the material

SafeMag
System

Electronic Safety
Shutoff Sensor

The **SAFEMAG™ System** measures whether the magnet has sufficient adhesive force on the material. An LED indicator on the switch panel warns you of insufficient magnetic force (**Red Light**) or tells you if the correct force is present (**Green Light**).



LED red... insufficient magnetic force. Drilling should not take place. Possible causes are too-thin material, coatings of paint, scale or zinc.

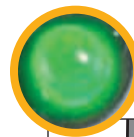
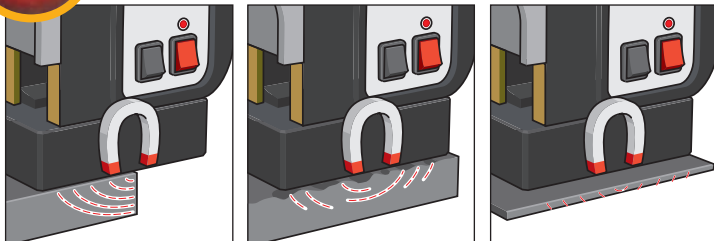

LED green... the magnetic adhesion meets the minimum requirements. Drilling can take place.

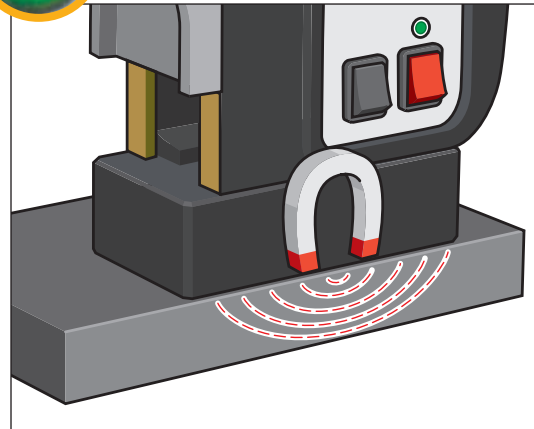

Our **Electronic Safety Shutoff Sensor** automatically shuts down the drill motor if the magnet loses contact with the material. This emergency-off feature helps to protect both operator and equipment.

Integrated cable routing: MAB Series

The new generation of our MAB portable magnetic drilling machines has been developed for increased safety. This includes complete cable routing within the casing.

- ▶ No threading and getting caught
- ▶ No tearing or snapping off

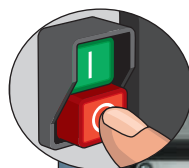

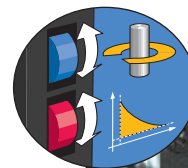

Simple, ergonomic arrangement of controls for one-handed operation. Emergency-off function for quick shutdown.



High power at low speeds. Electronic torque control prevents damage to motor.



Magnetic Drill Comparison Chart



| | MABasic 200 | MABasic 400 | MABasic 450 | MABasic 850 | MAB 100 K | MAB 155 PRO | AutoMAB 350 | AutoMAB 450 | PipeMAB 200 | PipeMAB 525 | PipeMAB 825 |
|---|-----------------|-----------------|-----------------|-----------------|--------------------|------------------------|-----------------|-----------------|-------------------------------|-------------------------------|-------------------------------|
| Annular Cutters Diameter (ø) | up to ø 1-3/8" | up to ø 1-5/8" | up to ø 2" | up to ø 3-1/16" | 1-3/8" | up to ø 1-1/2" | up to ø 1-1/2" | up to ø 2" | up to ø 1-3/8" | up to ø 2-3/8" | up to ø 3-15/16" |
| Twist Drills Diameter (ø) | up to ø 1/2" | up to ø 5/8" | up to ø 3/4" | up to ø 1-1/4" | up to ø 1/2" | | up to ø 1/2" | up to ø 3/4" | up to ø 1/2" | up to ø 1" | up to ø 1-1/4" |
| Tapping Diameter (ø) | | | | | | | | | | up to ø 15/16" | up to ø 1-3/16" |
| Countersinking Diameter (ø) | | | | | | | | | | up to ø 2" | up to ø 2" |
| Reaming Diameter (ø) | | | | | | | | | | | up to ø 1-1/4" |
| Stroke | 6-1/3" | 6-1/3" | 6-1/3" | 10" | 2-3/4" | 1-1/2" | 6" | 6" | 6-1/3" | 6-1/3" | 10" |
| Weight | 27 lbs. | 27 lbs. | 29 lbs. | 53 lbs. | 21.8 lbs. | 24 lbs. | 33 lbs. | 35-1/4 lbs. | 27 lbs. | 43 lbs. | 55.1 lbs. |
| Speed Range 1 | 450 RPM | 430 RPM | 250 RPM | 110 RPM | 460 RPM | 320 RPM | 460 RPM | 250 RPM | 450 RPM | 70-280 RPM | 40-110 RPM |
| Speed Range 2 | | 760 RPM | 450 RPM | 175 RPM | | | | 450 RPM | | 180-580 RPM | 65-175 RPM |
| Speed Range 3 | | | | 245 RPM | | | | | | | 140-360 RPM |
| Speed Range 4 | | | | 385 RPM | | | | | | | 220-600 RPM |
| Speed Range 5 | | | | | | | | | | | |
| Power Type | Electric | Electric | Electric | Electric | Electric | Electric | Electric | Electric | Electric | Electric | Electric |
|  | | | | | | | | | | ✓ | ✓ |
|  | | | | | | | | | Patented Permanent Mag System | Patented Permanent Mag System | Patented Permanent Mag System |
|  | | | | | | | ✓ | ✓ | | | |
| Electronic Safety Shutoff Sensor | ✓ | ✓ | ✓ | ✓ | ✓ | ✓ | | | | | |
| Special Features | | | | | Quick-change | Low Profile, LED Light | Automatic | Automatic | Patented Pipe Base | Patented Pipe Base | Patented Pipe Base |
| Morse Taper (MT) | | | MT2 | MT3 | | | | MT2 | | MT3 | MT3 |
| Safety Friction Clutch | | | | | | | | | | | |
| Torque Control | | | | | | | | | | ✓ | ✓ |
| Pipe Adapted or Adjustable Base | | | | | | | | | ✓ | ✓ | ✓ |
| Magnet Size | 6-5/8" x 3-1/3" | 6-5/8" x 3-1/3" | 6-5/8" x 3-1/3" | 8-5/8" x 4-1/3" | 6-19/64" x 3-5/32" | 6-5/16" x 3-3/16" | 6-5/8" x 3-1/3" | 6-5/8" x 3-1/3" | 10.5" L x 7.5" W x 3.5" H | 10.5" L x 7.5" W x 3.5" H | 10.5" L x 7.5" W x 3.5" H |
| Catalog Page | 26 | 27 | 28 | 29 | 30-31 | 32-33 | 34 | 35 | 36 | 37 | 38 |

PORTABLE MAGNETIC DRILLS



| eMAB 450 | MAB 455 MAB 455 SB | MAB 485 MAB 485 SB | MAB 525 MAB 525 SB | MAB 825 KTS | MAB 825 MAB 825 V MAB 845 MAB 845 V | MAB 1300 MAB 1300 V | AIRBOR™ | HB 4400 | 2 1345 0020 | |
|-------------------------------------|-----------------------|-----------------------|-----------------------|------------------------|--|-----------------------------|--------------------|--------------------|---------------------|---|
| up to ø 1-9/16" | up to ø 2-1/16" | up to ø 2-1/16" | up to ø 2-1/2" | up to ø 3-1/8" | up to ø 4-1/16" | up to ø 6" | up to ø 2-1/16" | up to ø 2-1/16" | up to ø 4" | Annular Cutters Diameter (ø) |
| up to ø 11/16" | up to ø 7/8" | up to ø 7/8" | up to ø 1" | up to ø 1-1/4" | up to ø 1-1/4" | up to ø 1-3/4" | up to ø 5/8" | up to ø 1/2" | up to ø 1-1/4" | Twist Drills Diameter (ø) |
| | | up to ø 15/16" | up to ø 15/16" | up to ø 1-3/16" | up to ø 1-3/16" | up to ø 1-5/8" | | | up to ø 1" | Tapping Diameter (ø) |
| | | up to ø 1-5/8" | up to ø 2" | up to ø 2" | up to ø 2" | up to ø 3" | | | up to ø 2" | Countersinking Diameter (ø) |
| | | up to ø 7/8" | up to ø 7/8" | up to ø 1-1/4" | up to ø 1-1/4" | up to ø 2" | | | up to ø 1-1/8" | Reaming Diameter (ø) |
| 5-5/16" | 6-1/3" | 6-1/3" | 6-1/3" | 10" | 10" | up to 12" w/out retainer | up to 10-1/4" | up to 3-3/4" | 12" | Stroke |
| 25.4 lbs. (w/o Battery) | 29 lbs. | 29 lbs. | 35 lbs. | 127 lbs. | 55 lbs. | 112 lbs. | 43 lbs. | 48-1/2 lbs. | 50 lbs. | Weight |
| 134 RPM | 250 RPM | 50-250 RPM | 70-280 RPM | 40-110 RPM | 40-110 RPM | 30-80 RPM | 400 RPM | 0-630 RPM | 40-250 RPM | Speed Range 1 |
| 189 RPM | 450 RPM | 100-450 RPM | 180-580 RPM | 65-175 RPM | 65-175 RPM | 50-120 RPM | | | | Speed Range 2 |
| 246 RPM | | | | 140-360 RPM | 140-360 RPM | 130-350 RPM | | | | Speed Range 3 |
| 298 RPM | | | | 220-600 RPM | 220-600 RPM | 210-550 RPM | | | | Speed Range 4 |
| 355 RPM | | | | | | | | | | Speed Range 5 |
| Battery | Electric | Electric | Electric | Electric | Electric | Electric | Pneumatic | Hydraulic | Hydraulic | Power Type |
| | | ✓ | ✓ | ✓ | ✓ | ✓ | | | ✓ |  |
| Patented Permanent Mag System | ✓ | ✓ | ✓ | ✓ | ✓ | ✓ | | | |  |
| | ✓ | ✓ | ✓ | ✓ | ✓ | ✓ | | | |  |
| | ✓ | ✓ | ✓ | ✓ | ✓ | ✓ | | | | Electronic Safety Shutoff Sensor |
| 18 V / 10.4 Ah Battery | Quick-change | Quick-change | Quick-change | X,Y-MILLING | Automatic - Quick-change | Automatic | Air & ATEX | Hydraulic | Hydraulic & ATEX | Special Features |
| | MT2 | MT2 | MT3 | MT3 | MT3 | MT4 | | | MT3 | Morse Taper (MT) |
| | | | | ✓ | ✓ | ✓ | | | | Safety Friction Clutch |
| | | | ✓ | ✓ | ✓ | ✓ | | | | Torque Control |
| | ✓ | ✓ | ✓ | ✓ | ✓ | | | | | Pipe Adapted or Adjustable Base |
| 2-7/8" x 8-15/16" | 6-5/8" x 3-1/3" | 6-5/8" x 3-1/3" | 7-1/8" x 3-1/2" | 8-11/16" x 8-11/16" | 8-5/8" x 4-1/3" | 14" x 4-3/4" | 8-3/4" x 3-1/2" | 7-1/4" x 3" | 11-11/16" x 4" | Magnet Size |
| 39 | 40-41 | 42-43 | 44-45 | 45-47 | 48-49 | 50-52 | 54 | 55 | 56 | Catalog Page |

*Annular cutter drilling capacity 6" diameter up to 1" thick in carbon steel - Use TCT cutters for large diameters

MABasic 200

Cutter capacity
1 3/8" dia.

Heavy-duty, purpose-built, single-speed workhorse



Powerful • Reliable

- Strong 8.2 Amp motor
- Compact, lightweight and portable – 12-1/4" high, 27 lbs.

Drill up to 1-3/8" dia.

- Uses annular cutters up to 1-3/8" dia.; 6-1/3" stroke
- Twist drilling capacity up to 1/2" dia.
- 3-1/3" stroke with included geared chuck
- Internal lubrication system



With included 1/2" geared chuck (IBC 18), this model easily converts to a standard drill press with a 3 1/3" stroke for conventional twist drills.

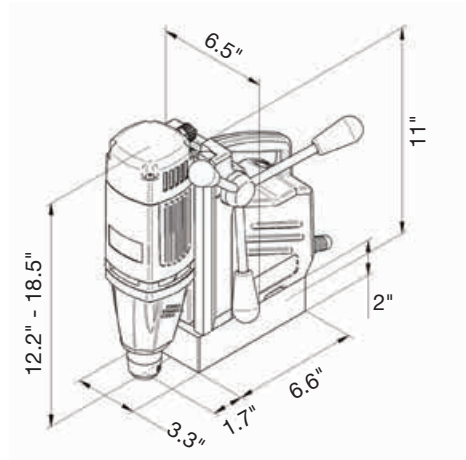

Equipped with Electronic Safety Shutoff Sensor (see p. 23)



Scan to
Learn More!

Standard Equipment includes lubrication bottle, 3/4" weldon arbor, 1/2" geared chuck, safety strap, allen keys, pilot pin and carrying case.



MABasic 200 Specifications

| | |
|---------------------------|-----------------------------|
| Motor Power | 8.2 Amp / 110 Volt |
| Weight | 27 lbs. |
| Hole Capacity | 1 3/8" dia. |
| Twist Drill Capacity | 1/2" dia. |
| Speed | 450 RPM |
| Magnet Base Size | 6 5/8" L x 3 1/3" W |
| Dimensions | 12 1/4" H x 9" L x 6 1/2" W |
| Magnetic Force (1" plate) | 3080 lbs. |
| Arbor Bore | 3/4" Weldon Shank |
| Internal Lubrication | Oil Bottle Included |

➤ Annular Cutters: pages 60-68 ➤ Accessories: pages 70-75

MABasic 400



Two gears – powerful and reliable

Powerful • Reliable

- 9.5 Amp double-insulated motor
- 3/4" direct arbor

Drill up to 1-5/8" dia.

- Uses annular cutters up to 1-5/8" dia.
- Twist drilling capacity up to 5/8" dia.
- 3-1/3" stroke with chuck
- Internal lubrication system
- Compact and lightweight



With included 1/2" geared chuck (IBC 18), the MABasic 400 easily converts to standard drill press with a 3 1/3" stroke for conventional twist drills.

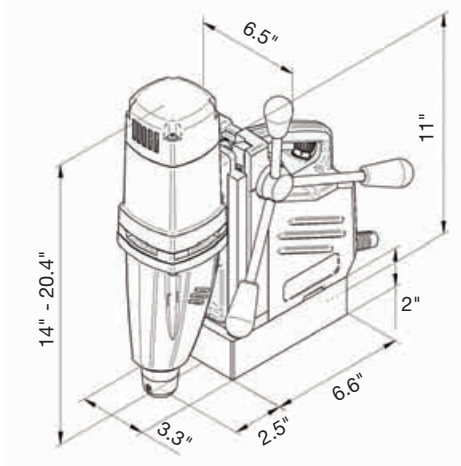

Equipped with Electronic Safety Shutoff Sensor (see p. 23)



MABasic 400 Specifications

| | |
|---------------------------|-----------------------------|
| Motor Power | 9.5 Amp / 110 Volt |
| Weight | 27 lbs. |
| Hole Capacity | 1 5/8" dia. |
| Twist Drill Capacity | 5/8" dia. |
| Speed | 430 / 760 RPM (2 gears) |
| Magnet Base Size | 6 5/8" L x 3 1/3" W |
| Dimensions | 14" H x 9 1/2" L x 6 1/2" W |
| Magnetic Force (1" plate) | 3080 lbs. |
| Arbor Bore | 3/4" Weldon Shank |
| Internal Lubrication | Oil Bottle Included |



Scan to Learn More!

Standard Equipment includes lubrication bottle, 3/4" weldon arbor, 1/2" geared chuck, safety strap, allen keys, pilot pin and carrying case.



> Annular Cutters: pages 60-68 > Accessories: pages 70-75



Cutter capacity
1 3/4" dia.

MABasic 450



Professional-grade, two-speed versatility

Powerful • Reliable

- 10.5 Amp double-insulated motor
- MT2 – 3/4" direct arbor with automatic cooling

Drill up to 2" dia.

- Uses annular cutters up to 2" dia.
- Twist drilling capacity up to 3/4" dia.
- Internal lubrication system
- Compact and lightweight



With included 1/2" geared chuck (ZBK-113 & ZKD-216), the MABasic 450 easily converts to standard drill press for conventional twist drills.

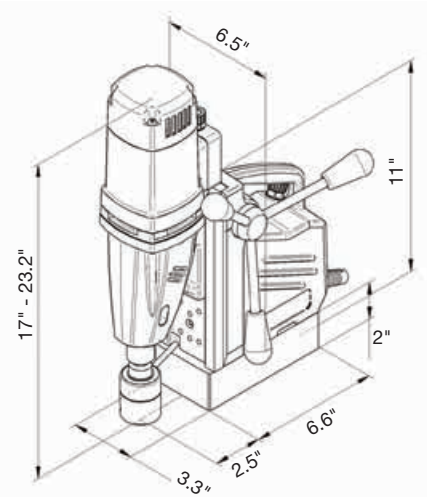

Equipped with Electronic Safety Shutoff Sensor (see p. 23)



Scan to Learn More!

MABasic 450 Specifications

| | |
|---------------------------|-----------------------------|
| Motor Power | 10.5 Amp / 110 Volt |
| Weight | 29 lbs. |
| Hole Capacity | 2" dia. |
| Twist Drill Capacity | 3/4" dia. |
| Speed | 250 / 450 RPM (2 gears) |
| Magnet Base Size | 6 5/8" L x 3 1/3" W |
| Dimensions | 17" H x 9 1/2" L x 6 1/2" W |
| Magnetic Force (1" plate) | 3080 lbs. |
| Arbor Bore | 3/4" Weldon Shank |
| Spindle | MT2 |
| Internal Lubrication | Oil Bottle Included |

Standard Equipment
includes: ZIA 219KN - MT2 to 3/4 weldon internal lubrication tool holder, lubrication bottle, 1/2" geared chuck, safety strap, allen keys, pilot pin and carrying case.



➤ Annular Cutters: pages 60-68 ➤ Accessories: pages 70-75

MABasic 850



4-gear, powerful motor for demanding jobs

Powerful • Reliable

- 16 Amp double-insulated motor
- MT3 – 3/4" direct arbor with automatic cooling
- 19-3/8" high, 53 lbs.
- High-speed, 4-speed gearbox

Drill up to 3-1/16" dia.

- Uses annular cutters up to 3-1/16"; 10" stroke
- Twist drilling capacity up to 1-1/4" dia.
- Internal lubrication system



With included 1/2" chuck (IBC 24), this model easily converts to a standard drill press for conventional twist drills.

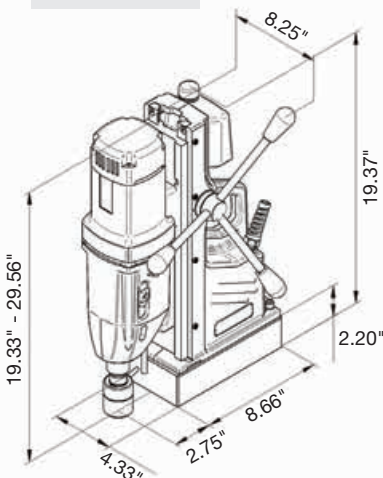

Scan to Learn More!

MABasic 850 Specifications

| | |
|---------------------------|--|
| Motor Power | 16 Amp / 110 Volt |
| Weight | 53 lbs. |
| Hole Capacity | 3 1/16" dia.* |
| Twist Drill Capacity | 1 1/4" dia. |
| Speed | 1: 110 RPM, 2: 175 RPM 3: 245 RPM, 4: 385 RPM |
| Magnet Base Size | 8 5/8" L x 4 1/3" W |
| Dimensions | 19 3/8" H x 11 5/8" L x 8 1/4" W |
| Magnetic Force (1" plate) | 6000 lbs. |
| Arbor Bore | 3/4" Weldon Shank |
| Spindle | MT3 |
| Internal Lubrication | Included |

* Cutters larger than 3-1/16" have 1-1/4" Weldon shank. Item ID: ZIA 30/32 arbor is required.

Standard Equipment includes ZIA 319KN - MT3 to 3/4 weldon internal lubrication tool holder, 1/2" geared chuck, safety strap, allen keys, pilot pin and carrying case.



> Annular Cutters: pages 60-68 > Accessories: pages 70-75



Cutter capacity
1 3/8" dia.

MAB 100 K



Ultra Lightweight, Compact and Fast to Use!



Powerful • Reliable

- 9 Amp double-insulated motor
- 3/4" Quick Change Keyless Chuck

Drill up to 1-3/8" dia.

- Uses annular cutters up to 1-3/8" dia.
- Twist drilling capacity up to 1/2" dia.
- Internal lubrication system
- Compact and lightweight

Equipped with Electronic Safety Shutoff Sensor (see p. 23)

OUR LIGHTEST WEIGHT MAB MAGNETIC DRILL EVER Only 21.8lbs!



Weldon Shank Twist Drill Bits Available, see page 72



Quick-Change Chuck for Fast, Easy Cutter Changeover!

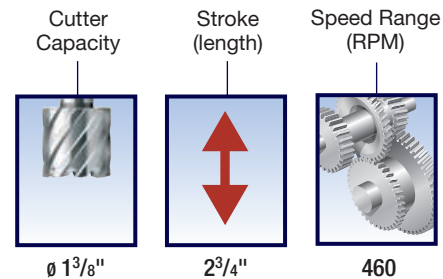

➤ Annular Cutters: pages 60-68 ➤ Accessories: pages 70-75

MAB 100 K Specifications

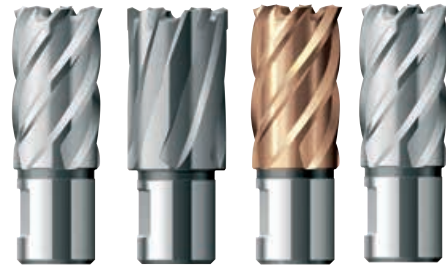
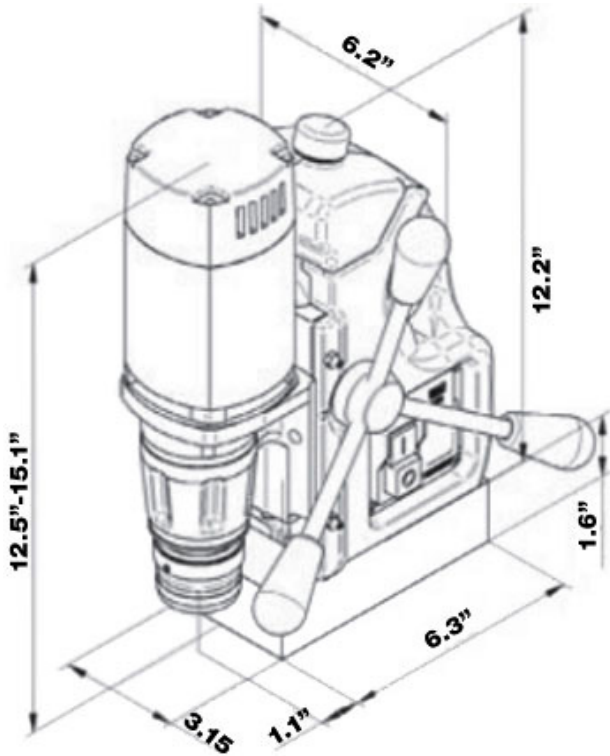

See pages 58-68 for our Annular Cutters - HSS, Carbide-tipped, Armor Plated, & Cobalt. Available up to 6" Dia. and 10" Depth.



MAB 100 K Specifications

| | |
|---------------------------|---|
| Motor Power | 9 Amp / 110 Volt |
| Weight | 21.8 lbs. |
| Hole Capacity | 1 3/8" dia. |
| Twist Drill Capacity | 1/2" dia. |
| Stroke | 2-3/4" |
| Speed | 460 RPM |
| Magnet Base Size | 6 ⁵ / ₁₆ " L x 3 ³ / ₁₆ " W |
| Dimensions | 12-1/2" H x 7 ² / ₅ " L x 6 ¹ / ₅ " W |
| Magnetic Force (1" plate) | 3080 lbs. |
| Arbor Bore | 3/4" Quick Change Keyless Chuck |
| Internal Lubrication | Oil Bottle Included |

Standard Equipment

- 1 Magnetic drilling machine
- 1 3/4" Weldon Quick Change chuck (affixed)
- 1 Heavy-Duty Carrying Case
- 1 1" Pilot Pin
- 1 2" Pilot Pin
- 1 Safety strap
- 1 Operating manual
- 1 Warranty certificate



Scan to Learn More!



> Annular Cutters: pages 60-68 > Accessories: pages 70-75

MAB 155 PRO



Cutter capacity
1 1/2" dia.

Horizontal motor mount for drilling in tight spaces



Powerful • Reliable

- 9.25 Amp double-insulated motor
- Ultra compact, 7-3/32" high
- Ratchet-style advancing mechanism for work in spaces with limited clearance
- Lightweight, 24 lbs.
- Intelligent electronic torque control
- Designed for continuous use

Drill up to 1-1/2" dia.*

- Uses annular cutters up to 1-1/2" dia.

Integrated Safety

- Emergency-off function
- Internal cable routing
- Simple, ergonomic arrangement of controls for one-handed operation

NEW Integrated LED
Light for improved
visibility and precise
drilling!



Equipped with Electronic
Safety Shutoff Sensor (see p. 23)



Internal
cable routing
protects the motor
power cord from
external damage

MAB 155 PRO uses standard
3/4" weldon shank annular
cutters



Cutter Capacity



ø 1 1/2"

Stroke
(length)



1 1/2"

Speed Range
(RPM)



320

* Model MAB 155 PRO accepts cutters with a 3/4" weldon shank and a maximum depth of cut of 1-1/2".

Switches for
power and magnet
adhesion are
arranged for simple,
uncomplicated
operation.



➤ Annular Cutters: pages 60-68 ➤ Accessories: pages 70-75

MAB 155 PRO



Specifications

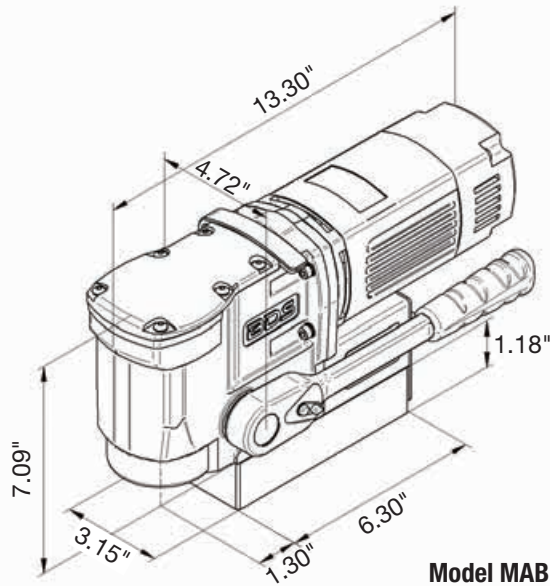

Model MAB 155PRO

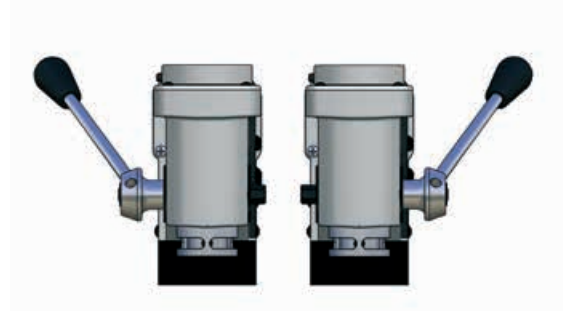

Advancing ratchet can be mounted on either the left or right side of the MAB 155PRO.

MAB 155 PRO Specifications

| | |
|---------------------------|-------------------------------------|
| Item ID: | MAB 155 PRO |
| Motor Power | 9.25 Amp / 110 Volt |
| Weight | 24 lbs. |
| Hole Capacity | 1 1/2" dia. |
| Speed | 320 RPM |
| Magnet Base Size | 1-17/32" H x 6-19/64" L x 3-5/32" W |
| Dimensions | 7-1/8" H x 13-5/16" L x 4-3/4" W |
| Magnetic Force (1" plate) | 2640 lbs. |
| Arbor Bore | 3/4" Weldon Shank |

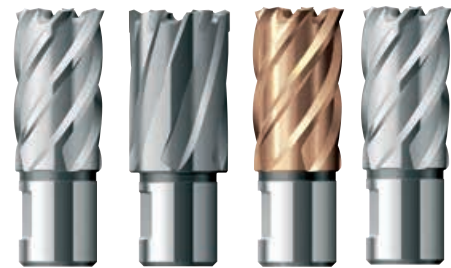

See pages 58-68 for our Annular Cutters - HSS, Carbide-tipped, Armor Plated, & Cobalt. Available up to 6" Dia. and 10" Depth.



Scan to
Learn More!

Standard Equipment

- 1 Magnetic drilling machine
- 1 Pilot pin
- 1 Heavy-Duty Carrying Case
- 1 Safety strap
- 1 Hexagon socket screw key SW 4
- 1 Operating manual
- 1 Warranty certificate

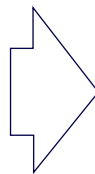

Standard Equipment
also includes
safety strap,
carabin hook and
allen keys.



> Annular Cutters: pages 60-68 > Accessories: pages 70-75

AutoMAB 350



Cutter capacity
1 1/2" dia.

Compact drill with automatic feed – forward and reverse

Powerful • Reliable

- 10.5 Amp double-insulated motor
- Designed for continuous use
- Lightweight, 33 lbs.
- Automatic feed with auto stop and retraction or manual feed
- Power feed automatically controls drill pressure to maintain optimal RPM and feed rate

Drill up to 1-1/2" dia.

- Uses annular cutters up to 1-1/2" dia.
- Twist drilling capacity up to 1/2" dia.
- 6" stroke, 3-1/3" stroke with chuck
- Integrated cutting oil reservoir
- Automatic internal lubrication

Integrated Safety

- Simple, ergonomic arrangement of controls for one-handed operation



With optional 1/2" geared chuck (IBC 18), this model easily converts to a standard drill press with a 3 1/3" stroke for conventional twist drills.



Scan to
Learn More!

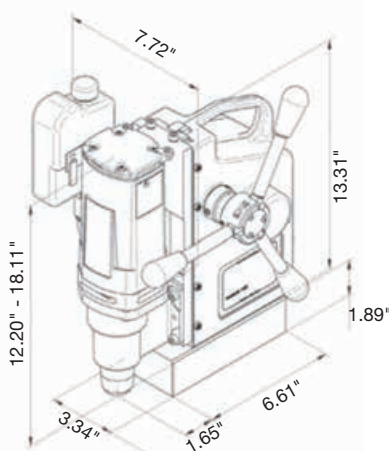

Model AutoMAB 350 Specifications

| | |
|-----------------------------|---------------------------------|
| Motor Power | 10.5 Amp / 110 Volt |
| Weight | 33 lbs. |
| Hole Capacity | 1 1/2" dia. |
| Drilling Depth w/ Pilot Pin | 2-3/8" dia. |
| Drilling Depth | 4-3/8" dia. |
| Twist Drill Capacity | 1/2" dia. |
| Speed | 460 RPM |
| Magnet Base Size | 6 5/8" L x 3 1/3" W |
| Dimensions | 12 1/4" H x 8 3/4" L x 7 3/4" W |
| Magnetic Force (1" plate) | 3750 lbs. |
| Arbor Bore | 3/4" Weldon Shank |
| Automatic Lubrication | Included |
| Spindle | – |

Standard Equipment includes auto lubrication, safety strap, allen keys and heavy-duty carrying case.

AutoMAB 450



Cutter capacity
2" dia.



Powerful • Reliable

- 10.5 Amp double-insulated motor
- Designed for continuous use
- Lightweight, 33 lbs.
- Automatic feed with auto stop and retraction or manual feed
- Power feed automatically controls drill pressure to maintain optimal RPM and feed rate

Drill up to 2" dia.*

- Uses annular cutters up to 2" dia. (*with TCT Carbide cutters, 1-3/4" dia. with all other annular cutters)
- Twist drilling capacity up to 3/4" dia.
- 6" stroke, 3-1/3" stroke with chuck
- Integrated cutting oil reservoir
- Automatic internal lubrication

Integrated Safety

- Simple, ergonomic arrangement of controls for one-handed operation



Model AutoMAB 450 Specifications

| | |
|-----------------------------|---------------------------------|
| Motor Power | 10.5 Amp / 110 Volt |
| Weight | 35 1/4 lbs. |
| Hole Capacity | 2" dia.* |
| Drilling Depth w/ Pilot Pin | 2-3/8" dia. |
| Drilling Depth | 4-3/8" dia. |
| Twist Drill Capacity | 1/2" dia. |
| Speed | 250 / 450 RPM (2 gears) |
| Magnet Base Size | 6 5/8" L x 3 1/3" W |
| Dimensions | 16 7/8" H x 9 1/8" L x 7 3/4" W |
| Magnetic Force (1" plate) | 3750 lbs. |
| Arbor Bore | 3/4" Weldon Shank |
| Automatic Lubrication | Included |
| Spindle | MT2 |

Standard Equipment includes ZIA 219KN - MT2 to 3/4" weldon internal lubrication tool holder, lubrication bottle, safety strap, MT2 drift key, allen keys and heavy-duty carrying case.

* 2" dia. with TCT Annular Cutters; 1-3/4" capacity with all other annular cutters



Scan to
Learn More!

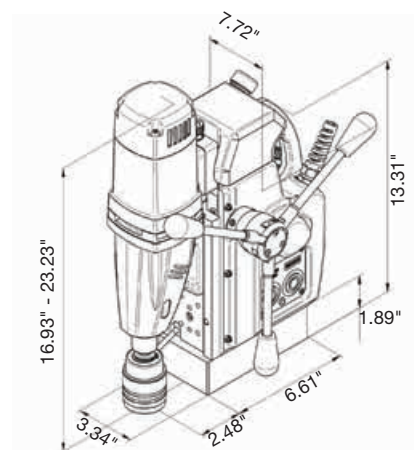



Cutter capacity
1 3/8" dia.

PipeMAB 200



Game Changer for Pipe Drilling, Tapping, & More



Powerful • Reliable

- Ideal for drilling on pipe, flat or curved surfaces
- Strong magnets adhere to material as thin as 9/64" (3mm)
- 8.2 Amp double-insulated motor
- Designed for continuous use
- Lightweight, 27 lbs

Drill up to 1-3/8" dia.

- Uses annular cutters up to 1-3/8" dia.
- Twist drilling capacity up to 1/2" dia.
- 6-1/3" stroke, 3-1/3" stroke with chuck
- Elongated tool holder for maximum utilization of machine stroke
- Integrated cutting oil reservoir
- Automatic internal lubrication

Integrated Safety

- Highly stable, permanent magnet stays active independent of electricity



With optional 1/2" geared chuck (IBC 18), this model easily converts to a standard drill press with a 3 1/3" stroke for conventional twist drills.



Scan to Learn More!

Model PipeMAB 200 Specifications

| | |
|---------------------------|-----------------------------|
| Motor Power | 8.2 Amp / 110 Volt |
| Weight | 35 lbs. |
| Hole Capacity | 1 3/8" dia. |
| Twist Drill Capacity | 1/2" dia. |
| Stroke | 6-1/3" |
| Speed | 450 RPM |
| Magnet Base Size | 10.5" L x 7.5" W x 3.5" H |
| Dimensions | 13.75" H x 10.5" L x 7.5" W |
| Magnetic Force (1" plate) | 2250 lbs. |
| Arbor Bore | 3/4" Weldon Shank |
| Automatic Lubrication | Included |

Standard Equipment includes auto lubrication, safety strap, allen keys and heavy-duty carrying case.

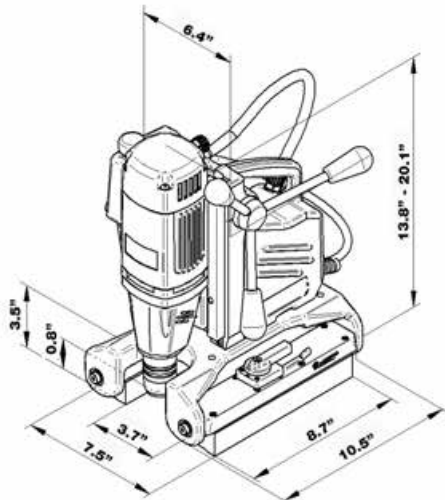

➤ Annular Cutters: pages 60-68 ➤ Accessories: pages 70-75

PipeMAB 525



Powerful • Reliable

- Ideal for drilling on pipe, flat or curved surfaces
- Strong magnets adhere to material as thin as 9/64" (3mm)
- 14.5 Amp double-insulated motor
- Designed for continuous use
- Lightweight, 43 lbs

Drill up to 2-1/2" dia.

- Uses annular cutters up to 2-1/2" dia.
- Twist drilling capacity up to 1" dia.
- 6-1/3" stroke
- Integrated cutting oil reservoir
- Automatic internal lubrication

Integrated Safety

- Highly stable, permanent magnet stays active independent of electricity

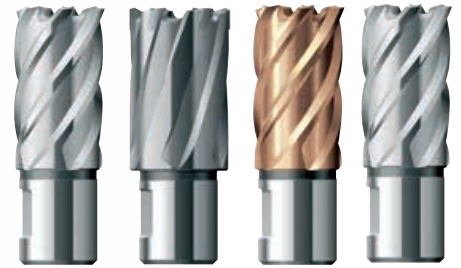

See pages 58-68 for our Annular Cutters - HSS, Carbide-tipped, Armor Plated, & Cobalt. Available up to 6" Dia. and 10" Depth.



An optional 3/4" geared chuck (Item ID: IBC 21) is also available.

Model PipeMAB 525 Specifications

| | |
|-----------------------------|----------------------------|
| Motor Power | 14.5 Amp / 110 Volt |
| Weight | 43 lbs. |
| Hole Capacity | 2-3/8" dia.* |
| Twist Drill Capacity | 1" dia. |
| Stroke | 6-1/3" |
| Speed | 70-280 & 180-580 RPM |
| Magnet Base Size | 10.5" L x 7.5" W x 3.5" H |
| Dimensions | 20.7" H x 10.5" L x 7.5" W |
| Magnetic Force (3/4" plate) | 2250 lbs. |
| Arbor Bore | 3/4" Weldon Shank |
| Automatic Lubrication | Included |
| Spindle | MT3 |

Standard Equipment includes auto lubrication, safety strap, MT#3 to 3/4" Weldon, MT3 drift key, allen keys, operation manual, warranty certificate and heavy-duty carrying case.

* 2-1/2" dia. drilling capacity for pipes 8" OD and larger. For smaller pipe maximum drilling diameter is 2"



Scan to Learn More!

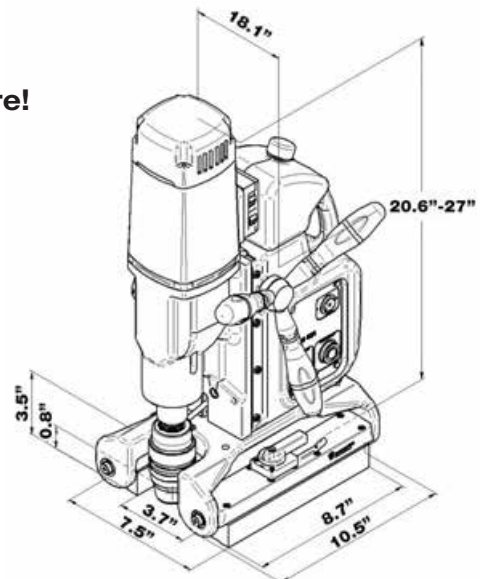

➤ Annular Cutters: pages 60-68 ➤ Accessories: pages 70-75



Cutter capacity
4" dia.

NEW! PipeMAB 825



Game Changer Power, Mobility, and Lifespan



Powerful • Reliable

- Ideal for drilling on pipe, flat or curved surfaces
- Strong magnets adhere to material as thin as 9/64" (3mm)
- 16 Amp double-insulated motor
- Designed for continuous use

Drill up to 4" dia.

- Uses annular cutters up to 3-15/16" dia.
- Twist drilling capacity up to 1-1/4" dia.
- 10" stroke, 7" stroke with chuck
- Elongated tool holder for maximum utilization of machine stroke
- Integrated cutting oil reservoir
- Automatic internal lubrication

Integrated Safety

- Highly stable, permanent magnet stays active independent of electricity



With included 1/2" chuck (IBC 24), this model easily converts to a standard drill press for conventional twist drills.

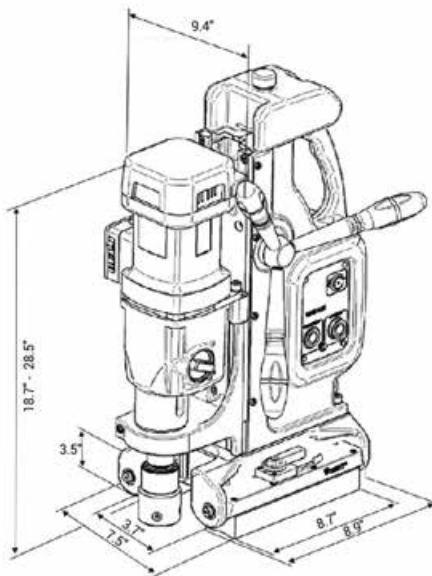

Model PipeMAB 825 Specifications

| | |
|---------------------------|-------------------------------------|
| Motor Power | 16 Amp / 110 Volt |
| Weight | 55.1 lbs. |
| Hole Capacity | 3-15/16" dia. |
| Twist Drill Capacity | 1-1/4" dia. |
| Stroke | 10" |
| Speed | 40-110 65-175 140-360 220-600 |
| Magnet Base Size | 10.5" L x 7.5" W x 3.5" H |
| Dimensions | 18.7" H x 10.5" L x 7.5" W |
| Magnetic Force (1" plate) | 2250 lbs. |
| Arbor Bore | 3/4" Weldon Shank |
| Automatic Lubrication | Included |

Standard Equipment includes auto lubrication, safety strap, allen keys and heavy-duty carrying case.



➤ Annular Cutters: pages 60-68 ➤ Accessories: pages 70-75



Compact Battery Powered Magnetic Drill with Battery & Charger Included

Powerful • Reliable

- Li-Ion 18 V / 10.4 Ah / 187 Wh motor
- Designed for continuous use up to 70 holes per charge
- Lightweight, 25.4 lbs. (w/o Battery).
- 5-Speed
- Adjustable lifting handle
- Permanent Magnet

Drill up to 1-9/16" dia.

- Uses annular cutters up to 1-9/16" dia.
- Twist drilling capacity up to 11/16" dia.
- 5-5/16" stroke
- Reversible Motor



An optional 1/2" geared chuck (Item ID: IBC 18) is also available.

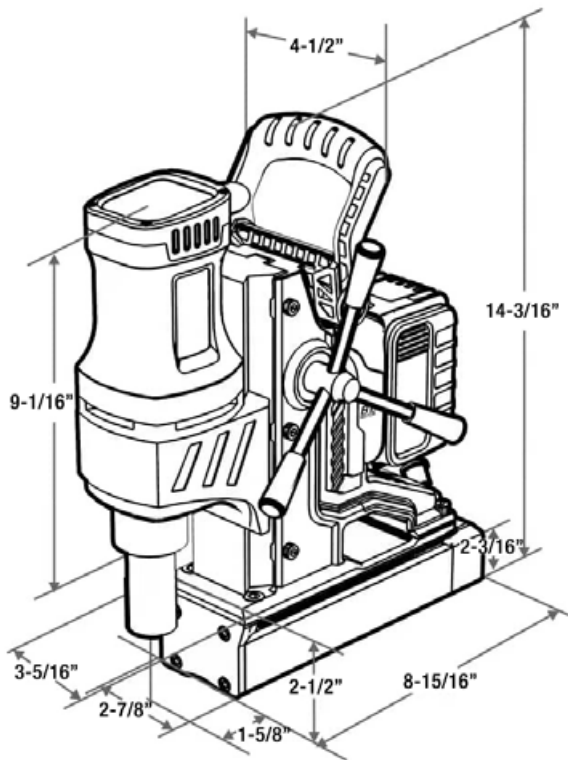

Model eMAB 450 Specifications

| | |
|-----------------------|--------------------------------|
| Motor Output | 1100 Watts |
| Battery | Li-Ion 18 V / 10.4 Ah / 187 Wh |
| Weight | 25.4 lbs |
| Hole Capacity | 1-9/16" dia. |
| Twist Drill Capacity | 11/16" dia. |
| Stroke | 5-5/16" |
| Speed | 134, 189, 246, 298, 355 RPM |
| Magnet Base Size | 2-7/8" x 8-15/16" |
| Dimensions | 14.2" H x 12.2" L x 9.6" W |
| Automatic Lubrication | Yes |

Standard Equipment includes battery, charger, auto lubrication, safety strap, allen keys and heavy-duty carrying case.

➤ Annular Cutters: pages 60-68 ➤ Accessories: pages 70-75



MAB 455 & MAB 455 SB



Powerful • Reliable

- 10.5 Amp double-insulated motor
- 17-1/4" high, 29 lbs.
- 2-speed oilbath gearbox, ideal for annular cutters and twist drills
- Designed for continuous use
- Intelligent electronic torque control

Drill up to 2-1/16" dia.

- Uses annular cutters up to 2-1/16" dia.
- Twist drilling capacity up to 7/8" dia.
- Integrated cutting oil reservoir
- Automatic internal lubrication
- Swivel base (model MAB 485 SB)

Keyless Cutter Mount

- Quick-change keyless cutter system for 3/4" Weldon shank, standard. Item ID: **(ZSS 200)**
- Also includes manual arbor for 3/4" Weldon shank (MT2) with set screws Item ID: **(ZIA 219 KN)**



With included 1/2" chuck (ZBK 113 and MT2 spindle ZKD 216), this model easily converts to a standard drill press for conventional twist drills.



Integrated Safety

- Green/Red LED magnetic force indicator for safe operation
- Internal cable routing
- Simple, ergonomic arrangement of controls for one-handed operation
- Emergency-off function

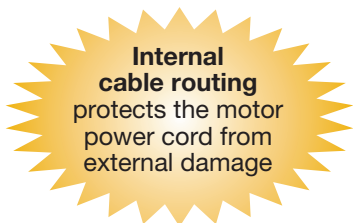





Equipped with Electronic Safety Shutoff Sensor (see p. 23)

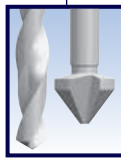
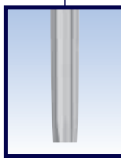

Model MAB 455 SB features a swivel base providing 20° movement left and right and 5/8" forward and backward.

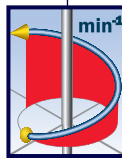
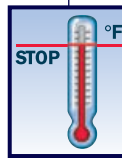

| Cutter Capacity | Twist Drill / Countersink | Ream | Stroke (length) | Electronics | Overheat Protection | Magnet Force Indicator |
|--|--|---|---|---|--|---|
|  ø 2 1/16" |  ø 7/8" / ø 1 5/8" |  ø 7/8" |  6 1/3" |  Variable-speed Control |  CoolMag™ |  SafeMag™ |

➤ Annular Cutters: pages 60-68 ➤ Accessories: pages 70-75

MAB 455 & MAB 455 SB

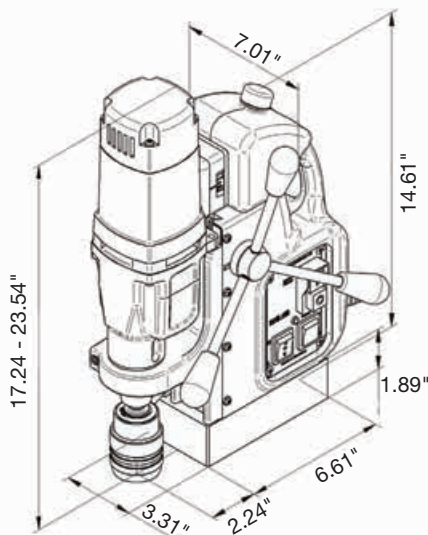

Model MAB 455
& MAB 455 SB



Scan to
Learn More!

Model MAB 455 & MAB 455 SB Specifications

| | |
|---------------------------|--|
| Motor Power | 10.5 Amp / 110 Volt |
| Weight | 29 lbs. |
| Hole Capacity | 2 ¹ / ₁₆ " dia. |
| Twist Drill Capacity | 7/8" dia. |
| Speed | 250 / 450 RPM |
| Magnet Base Size | 6 ⁵ / ₈ " L x 3 ¹ / ₃ " W |
| Dimensions | 17 ¹ / ₄ " H x 11 ⁵ / ₈ " L x 7" W |
| Magnetic Force (1" plate) | 3750 lbs. |
| Arbor Bore | 3/4" Weldon Shank |
| Spindle | MT2 |
| Automatic Lubrication | Included |
| Swivel Base | Order MAB 455 SB |



Standard Equipment

- 1 Magnetic drilling machine
- 1 Heavy-Duty Carrying Case
- 1 Quick-change arbor system
KEYLESS Weldon 3/4" (ZSS 200)
- 1 Manual arbor with set screws, Weldon 3/4",
MT2 (ZIA 219 KN)
- 1 Geared chuck, 1/2" (ZBK 113 & ZKD 216)
- 2 Pilot pins - 1" and 2" depth
- 1 Safety strap
- 1 Drift key MT2 (1960002)
- 1 Warranty certificate



Shown with optional Pipe Saddle Clamp (ZRO 250) System for safe, secure drilling of pipes and tubular material. See page 75 for details.

➤ Annular Cutters: pages 60-68 ➤ Accessories: pages 70-75

MAB 485 & MAB 485 SB

Cutter capacity
2 1/16" dia.

Versatile for workshop and assembly applications



Powerful • Reliable

- 10.5 Amp double-insulated motor
- 17-1/4" high, 29 lbs.
- High-speed, variable-speed oilbath gearbox, ideal for annular cutters and twist drills
- Designed for continuous use
- Intelligent electronic torque control

Drill up to 2-1/16" dia. Tap up to 15/16" dia.

- Uses annular cutters up to 2-1/8" dia.
- Twist drilling capacity up to 7/8" dia.
- Tapping capacity 3/16" to 15/16" dia.
- Integrated cutting oil reservoir
- Automatic internal lubrication
- Swivel base (model MAB 485 SB)

Keyless Cutter Mount

- Quick-change keyless cutter system for 3/4" Weldon shank, standard. Item ID: **(ZSS 200)**
- Also includes manual arbor for 3/4" Weldon shank (MT2) with set screws Item ID: **(ZIA 219 KN)**



With included 1/2" chuck (ZBK 113 and MT2 spindle ZKD 216), this model easily converts to a standard drill press for conventional twist drills.



Integrated Safety









- Green/Red LED magnetic force indicator for safe operation
- Internal cable routing
- Simple, ergonomic arrangement of controls for one-handed operation
- Emergency-off function

Internal cable routing protects the motor power cord from external damage

Equipped with Electronic Safety Shutoff Sensor (see p. 23)

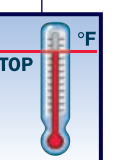

Model MAB 485 SB features a swivel base providing 20° movement left and right and 5/8" forward and backward.

| Cutter Capacity | Twist Drill / Countersink | Ream / Tap | Stroke (length) | 2-gear Variable Speed (RPM) | Electronics | Overheat Protection | Magnet Force Indicator | Reversible (CW/CCW) |
|---|---|---|---|---|--|---|---|---|
|  |  |  |  |  |  |  |  |  |
| ø 2 1/16" | ø 7/8" / ø 1 5/8" | ø 7/8" / ø 1 5/16" | 6 1/3" | 50-250 100-450 | Variable-speed Control | CoolMag™ | SafeMag™ | |

➤ Annular Cutters: pages 60-68 ➤ Accessories: pages 70-75

MAB 485 & MAB 485 SB Specifications

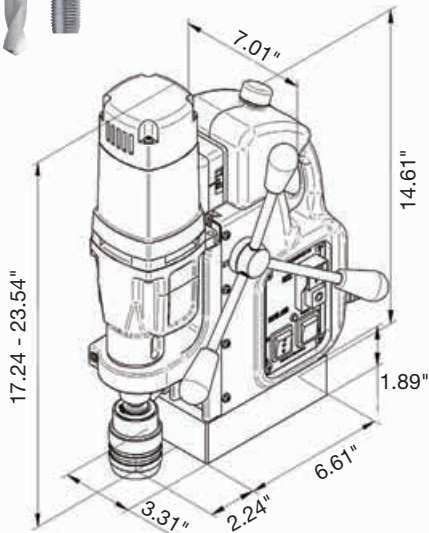

Model MAB 485
& MAB 485 SB



Scan to
Learn More!



Shown with optional Pipe Saddle Clamp System (Item ID: ZRO 250 for safe, secure drilling of pipes and tubular material. See page 75 for details.

Model MAB 485 & MAB 458 SB Specifications

| | |
|---------------------------|--|
| Motor Power | 10.5 Amp / 110 Volt |
| Weight | 29 lbs. |
| Hole Capacity | 2 ¹ / ₁₆ " dia. |
| Twist Drill Capacity | 7/8" dia. |
| Speed | 50-250 and 100-450 RPM |
| Magnet Base Size | 6 ⁵ / ₈ " L x 3 ¹ / ₃ " W |
| Dimensions | 17 ¹ / ₄ " H x 11 ⁵ / ₈ " L x 7" W |
| Magnetic Force (1" plate) | 3750 lbs. |
| Arbor Bore | 3/4" Weldon Shank |
| Spindle | MT2 |
| Automatic Lubrication | Included |
| Swivel Base | Order MAB 485 SB |

Standard Equipment

- 1 Magnetic drilling machine
- 1 Heavy-Duty Carrying Case
- 1 Quick-change arbor system KEYLESS Weldon 3/4" (**ZSS 200**)
- 1 Manual arbor with set screws, Weldon 3/4", MT2 (**ZIA 219 KN**)
- 1 Geared chuck, 1/2" (**ZBK 113 & ZKD 216**)
- 2 Pilot pins - 1" and 2" depth
- 1 Safety chain
- 1 Drift key MT2 (**1960002**)
- Tap collet adapters - 1/4" (**TCM 1/4**), 3/8" (**TCM 3/8**), 1/2" (**TCM 1/2**) and 3/4" (**TCM 3/4**)
- 1 Warranty certificate



> Annular Cutters: pages 60-68 > Accessories: pages 70-75



Cutter capacity
2 1/2" dia.

MAB 525 & MAB 525 SB



High power, ideal for production use



Powerful • Reliable

- 14.5 Amp double-insulated motor
- 19" high, 35 lbs.
- High-speed, 2-speed oilbath gearbox, ideal for annular cutters and twist drills
- Designed for continuous use
- Intelligent electronic torque control

**Drill up to 2-1/2" dia.
Tap up to 15/16" dia.**

- Uses annular cutters up to 2-1/2" dia.
- Twist drilling capacity up to 1" dia.
- Tapping capacity up to 15/16" dia.
- Integrated cutting oil reservoir
- Automatic internal lubrication
- Swivel base (model MAB 525 SB)

Keyless Cutter Mount

- Quick-change keyless cutter system for 3/4" Weldon shank (ZSS 300)
- Also includes manual arbor for 3/4" Weldon shank (MT3) with set screws (ZIA 319 KN)

Integrated Safety

- Green/Red LED magnetic force indicator for safe operation
- Internal cable routing
- Simple, ergonomic arrangement of controls for one-handed operation
- Emergency-off function

Model MAB 525 SB features a swivel base providing 20° movement left and right and 5/8" forward and backward.



REVERSIBLE

Internal cable routing protects the motor power cord from external damage

Equipped with Electronic Safety Shutoff Sensor (see p. 23)



With the included 1/2" chuck, (IBC 24) this model easily converts to a standard drill press with a 5" stroke for conventional twist drills.



| Cutter Capacity | Twist Drill / Countersink | Ream / Tap | Stroke (length) | 2-gear Variable Speed (RPM) | Electronics | Overheat Protection | Magnet Force Indicator | Reversible (CW/CCW) |
|----------------------|-------------------------------------|---|-----------------|-----------------------------|------------------------|---------------------|------------------------|---------------------|
| \varnothing 2 1/2" | \varnothing 1" / \varnothing 2" | \varnothing 7/8" / \varnothing 15/16" | 6 1/3" | 70-280 / 180-580 | Variable-speed Control | CoolMag™ | SafeMag™ | |

➤ Annular Cutters: pages 60-68 ➤ Accessories: pages 70-75

MAB 525 & MAB 525 SB Specifications

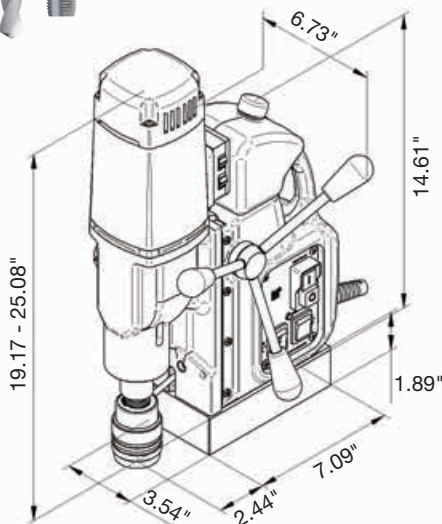

Model MAB 525
& MAB 525 SB



Scan to
Learn More!



Model MAB 525 & MAB 525 SB Specifications

| | |
|---------------------------|------------------------------|
| Motor Power | 14.5 Amp / 110 Volt |
| Weight | 35 lbs. |
| Hole Capacity | 2 1/2" dia. |
| Twist Drill Capacity | 1" dia. |
| Speed | 70-280 and 180-580 RPM |
| Magnet Base Size | 7 1/8" L x 3 1/2" W |
| Dimensions | 19" H x 11 3/4" L x 6 3/4" W |
| Magnetic Force (1" plate) | 4500 lbs. |
| Arbor Bore | 3/4" Weldon Shank |
| Spindle | MT3 |
| Automatic Lubrication | Included |
| Swivel Base | Order MAB 525 SB |

Standard Equipment

- 1 Magnetic drilling machine
- 1 Quick-change arbor system KEYLESS Weldon 3/4" (ZSS 300)
- 1 Manual arbor with set screws, Weldon 3/4", MT3 (ZIA 319 KN)
- 1 Geared chuck, 1/2" (IBC 24)
- 2 Pilot pins - 1" and 2" depth
- 1 Safety strap
- 1 Drift key MT3 (5301)
- Tap collet adapters - 1/4" (TCM 1/4), 3/8" (TCM 3/8), 1/2" (TCM 1/2) and 3/4" (TCM 3/4)
- 1 Heavy-Duty carrying case
- 1 Operating manual
- 1 Set of Allen Keys
- 1 Warranty certificate

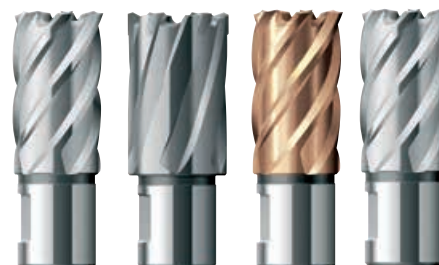

See pages 58-68 for our Annular Cutters - HSS, Carbide-tipped, Armor Plated, & Cobalt. Available up to 6" Dia. and 10" Depth.



➤ Annular Cutters: pages 60-68 ➤ Accessories: pages 70-75



Cutter capacity
3 1/8" dia.

MAB 825 KTS



Milling & Drilling with adjustable X and Y positioning



Powerful • Reliable

- 16 Amp double-insulated motor
- 4-speed oilbath gearbox for applications requiring high power
- Designed for continuous use
- Infinitely variable torque control and full-wave control electronics
- Ideal for drilling, boring and slotting applications
- Includes servo-assisted drilling feature to help maintain feed pressure during operation

Drill up to 3-1/8" dia. Tap up to 1-3/16" dia.

- Multi-axis positioning
- Uses annular cutters up to 3-1/8" dia.
- Twist drilling capacity up to 1-1/4" dia.
- 10" stroke
- Integrated cutting oil reservoir
- Automatic internal lubrication

Integrated Safety

- Simple, ergonomic arrangement of controls for one-handed operation
- Emergency-off function

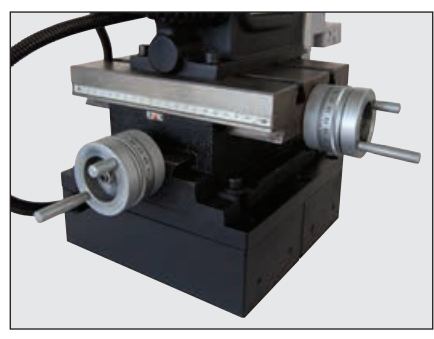



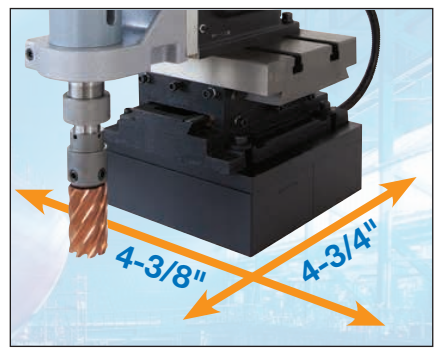





REVERSIBLE

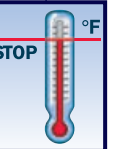

Model MAB 825 KTS features multi-axis positioning, allowing the drill to be adjusted up to 4-3/4" forward/backward and up to 4-3/8" left/right after magnet is adhered to surface. Ideal for job site drilling, boring and slotting applications where dismantling is not feasible.

2021 REDDOT WINNER INNOVATIVE PRODUCT

| Cutter Capacity | Twist Drill / Countersink | Ream / Tap | Stroke (length) | 4-gear Variable Speed (RPM) | Electronics | Overheat Protection | Magnet Force Indicator | Reversible (CW/CCW) |
|---|--|--|--|---|--|---|---|---|
|  ø 3 1/8" |  ø 1 1/4" / 1 37/64" |  ø 1 1/4" / ø 1 1/4" |  10" |  40-110, 65-175, 140-360, 220-600 |  Variable-speed Control |  CoolMag™ |  SafeMag™ |  |

➤ Annular Cutters: pages 60-68 ➤ Accessories: pages 70-75

MAB 825 KTS

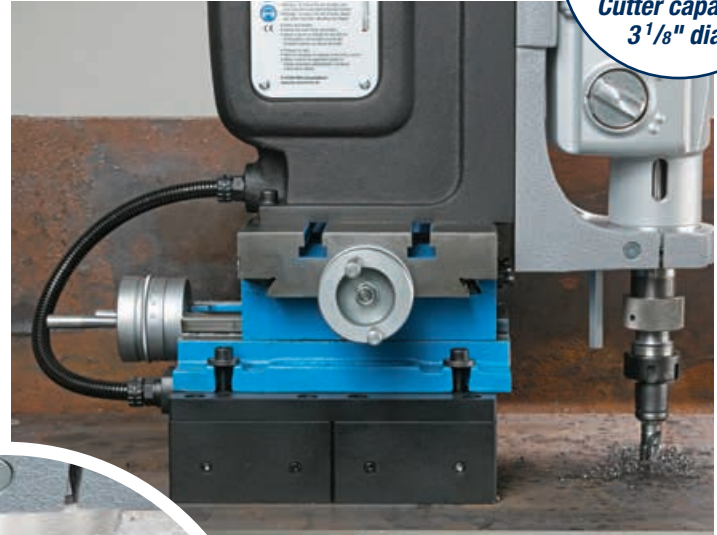

Chuck Collet Tool Holder Set with Case

Item ID: ZSF 316 (included) can hold most standard end mills with shanks from 1/8" to 5/8" dia. (3mm to 16mm dia.). Kit includes:

- MT3 collet holder with threaded adapter piece
- 15 collets for shank diameters 1/8" to 5/8" (3 to 16mm)
- 2 collet tightening spanner wrenches

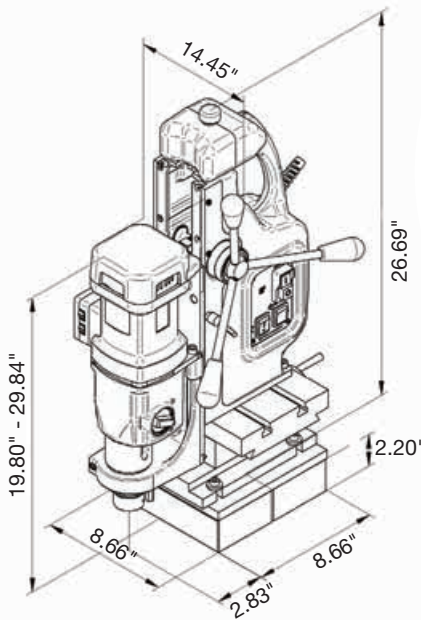

Scan to
Learn More!

Standard Equipment

- 1 Magnetic drilling machine
- 1 Chuck collet tool holder set (ZSF 316)
- 1 Quick-change arbor system KEYLESS Weldon 3/4" (ZSS 300)
- 1 Manual arbor with set screws, Weldon 3/4", MT3 (ZIA 319M)
- 1 Heavy-duty carrying case with wheels
- 1 Arbor 1 1/4" Weldon, MT3* (ZIA 30/32)
- 1 Safety strap
- 1 Set of Allen Keys
- 1 Drift key MT3 (5301)
- 1 Operating manual
- 1 Warranty certificate

Model MAB 825 KTS Specifications

| | |
|---------------------------|--|
| Motor Power | 16 Amp / 110 Volt |
| Weight | 127 lbs. |
| Hole Capacity | 3 1/8" dia. |
| Twist Drill Capacity | 1 1/4" dia. |
| Tapping Capacity | 1 3/16" dia. |
| Speed | 40-110, 65-175 140-360, 220-600 RPM |
| Magnet Base Size | 8 11/16" L x 8 11/16" W |
| Dimensions | 19 3/4" H x 13" L x 14 1/2" W |
| Magnetic Force (1" plate) | 6600 lbs. |
| Arbor Bore | 3/4" and 1 1/4", standard |
| Spindle | MT3 |
| Automatic Lubrication | Included |

Optional 3/4" geared chucks available (Item ID: IBC 21)

> Annular Cutters: pages 60-68 > Accessories: pages 70-75



Cutter capacity
4 1/16" dia.

MAB 825/845, MAB 825 V/845 V



Ideal for steel engineering, plant construction and more



Powerful • Reliable

- 16 Amp double-insulated motor
- 4-speed oilbath gearbox for applications requiring high power
- Designed for continuous use
- Infinitely variable torque control and full-wave control electronics

Drill up to 4-1/16" dia.
Tap up to 1-3/16" dia.

- Uses annular cutters up to 4-1/16" dia.
- Twist drilling and reaming capacities up to 1-1/4" dia.
- Tapping capacity up to 1-3/16" dia.
- Integrated cutting oil reservoir
- Automatic internal lubrication
- Automatic feed (model MAB 825 V), ideal for production applications
- Swivel base (model MAB 845)

Keyless Cutter Mount

- Quick-change keyless cutter system for 3/4" Weldon shank **(ZSS 300)**
- Arbor for 1-1/4" Weldon shank **(ZIA 30/32)**
- Also includes manual arbor for 3/4" Weldon shank (MT3) with set screws **(ZIA 319M)**

Integrated Safety

- Green/Red LED magnetic force indicator for safe operation
- Internal cable routing
- Simple, ergonomic arrangement of controls for one-handed operation
- Emergency-off function



Internal cable routing protects the motor power cord from external damage

Equipped with Electronic Safety Shutoff Sensor (see p. 23)



4 Gears with Variable Speed



Twist Drilling



Tapping



Reaming



Countersinking

MAB 825

Standard model with 16 Amp motor

MAB 825 V

Includes automatic feed – ideal for production applications

MAB 845

Includes 30° movement left and right and 3/4" forward and backward

MAB 845 V

Includes automatic feed & 30° movement left and right and 3/4" forward and backward

See pages 52 & 72-74 for Tap Holders and Accessories

| Cutter Capacity | Twist Drill / Countersink | Ream / Tap | Stroke (length) | 4-gear Variable Speed (RPM) | Electronics | Overheat Protection | Magnet Force Indicator | Reversible (CW/CCW) |
|------------------------------|--|--|-----------------|--|--|---------------------|------------------------|---------------------|
| $\varnothing 4\frac{1}{16}"$ | $\varnothing 1\frac{1}{4}" / \varnothing 2"$ | $\varnothing 1\frac{1}{4}" / \varnothing 1\frac{3}{16}"$ | 10" | 40-110 65-175 140-360 220-600 | min ⁴ Variable-speed Control | STOP °F CoolMag™ | SafeMag™ | |

➤ Annular Cutters: pages 60-68 ➤ Accessories: pages 70-75

Specifications



Cutter capacity
4 1/16" dia.

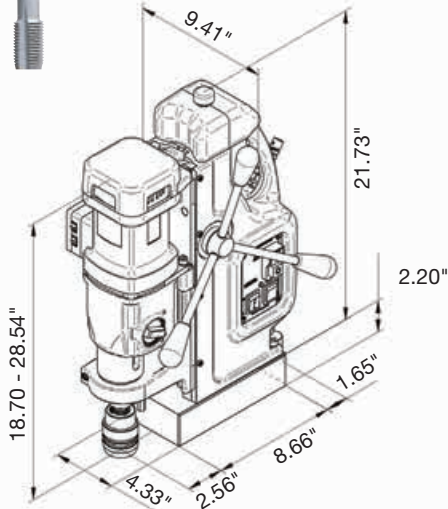

Model MAB 825, 825 V, 845, 845 V



With an optional 3/4" geared chuck (Item ID: IBC 21), this model easily converts to a standard drill press for conventional twist drills.



Model MAB 845 & MAB 845 V features a swivel base providing 30° movement left and right and 3/4" forward and backward.

Model MAB 825 V & MAB 845 V features automatic forward and reverse motor for faster drilling, and increased cutter life. See page 48

Model MAB 825 & 845 Specifications

| | |
|---------------------------|--------------------------------------|
| Motor Power | 16 Amp / 110 Volt |
| Weight | 55 lbs. |
| Hole Capacity | 4 1/16" dia. |
| Twist Drill Capacity | 1 1/4" dia. |
| Tapping Capacity | 1 3/16" dia. |
| Speed | 40-110, 65-175, 140-360, 220-600 RPM |
| Magnet Base Size | 8 5/8" L x 4 1/3" W |
| Dimensions | 18 5/8" H x 14 7/16" L x 9 7/16" W |
| Magnetic Force (1" plate) | 6600 lbs. |
| Arbor Bore | 3/4" and 1 1/4", standard |
| Spindle | MT3 |
| Automatic Lubrication | Included |
| Automatic Feed Model | Order MAB 825 V, MAB 845 V |
| Swivel Base Model | Order MAB 845, MAB 845 V |

Standard Equipment

- 1 Magnetic drilling machine
- 1 Quick-change arbor system KEYLESS Weldon 3/4" (ZSS 300)
- 1 Manual arbor with set screws, Weldon 3/4", MT3 (ZIA 319M)
- 1 Arbor 1 1/4" Weldon, MT3* (ZIA 30/32)
- 4 Pilot pins - 1", 2", 3" and 4" depth
- 1 Safety strap
- 1 Hexagon socket screw key SW 6
- 1 Drift key MT3 (5301)
- 1 Operating manual
- 1 Set of allen keys
- 1 Warranty certificate
- 1 Heavy-Duty Carrying Case with wheels



Scan to
Learn
More!

Rolling Transport Case

Robust transport case with wheels, carrying handle and sturdy closures. Included with MAB 825/845 – protect your drill from water and dust with this rugged case. (Item ID: ZHK 825)



* Optional accessory for MAB 825 V, MAB 845 V

> Annular Cutters: pages 60-68 > Accessories: pages 70-75



MAB 1300 & 1300V

Large holes – up to 6" diameter
Tapping up to 1⁵/₈" diameter



4 Gears with Variable Speed

Powerful • Reliable

- 20 Amp double-insulated motor
- 34-1/2" high, 112 lbs.
- 4-speed oilbath gearbox for applications requiring high power
- Stroke length up to 12"*
- Infinitely variable torque control and full-wave control electronics

Drill up to 6" dia.*
Tap up to 1-5/8" dia.

- Uses annular cutters 7/16" to 6" dia., 1" and 2" depth 7/16" to 6" dia., 3" to 8" depth**
- Twist drilling up to 1-3/4" - uses MT4, countersinking up to 3" dia.
- Tapping up to 1-5/8"
- Reaming up to 2"
- Automatic internal lubrication

Integrated Safety

- Green/Red LED magnetic force indicator for safe operation
- Equipped with Electronic Safety Shutoff Sensor
- Emergency-off function

Ideal for use with TCT Carbide cutters up to 6" dia. – see pages 64-65.



* 3" depth cutters or longer, use arbor ZIA 419 KN for diameters up to 3" and arbor ZIA 432 KN for over 3".



Equipped with Electronic Safety Shutoff Sensor
 (see p. 23)



Twist Drilling



Tapping









Reaming

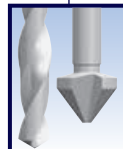
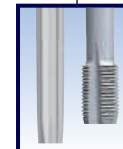
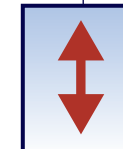

Countersinking

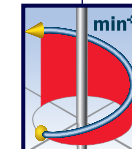

Optional Special-Purpose Cutting Tool

| Cutter Capacity | Twist Drill / Countersink | Ream / Tap | Stroke (length) | 4-gear Variable Speed (RPM) | Electronics | Overheat Protection | Magnet Force Indicator | Reversible (CW/CCW) |
|---|---|---|---|---|---|--|---|---|
|  |  |  |  |  |  |  |  |  |
| ø 6" up to 1" thick in carbon Steel | ø 1 ³ / ₄ " / ø 3" | ø 2" / ø 1 ⁵ / ₈ " | 10" *(12" without retainer) | 30-80 50-120 130-350 210-550 | Variable-speed Control | CoolMag™ | SafeMag™ | |

➤ Annular Cutters: pages 60-68 ➤ Accessories: pages 70-75

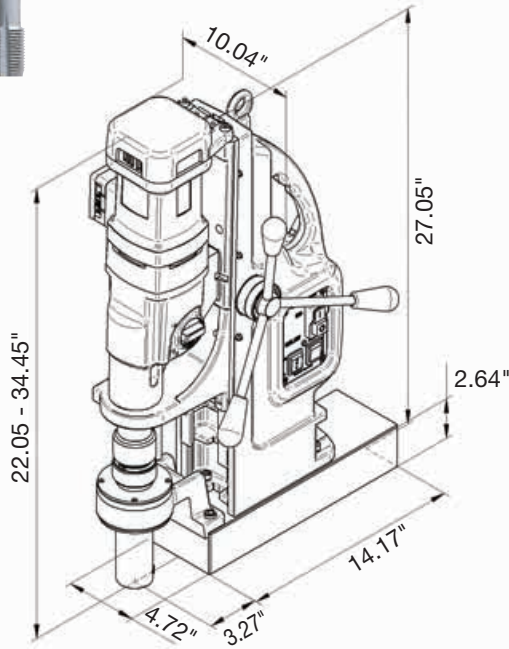

Model MAB 1300



Model MAB 1300 & MAB 1300 V Specifications

| | |
|---------------------------|--|
| Motor Power | 20 Amp / 110 Volt |
| Weight | 112 lbs. |
| Hole Capacity | 6" dia.* |
| Twist Drill Capacity | 1 ³ / ₄ " dia. |
| Tapping Capacity | 1 ⁵ / ₈ " dia. |
| Speed | 30-80, 50-120, 130-350, 210-550 RPM |
| Magnet Base Size | 14" L x 4 ³ / ₄ " W |
| Dimensions | 27.05" H x 19 ¹ / ₂ " L x 10" W |
| Magnetic Force (1" plate) | 23,600 lbs. |
| Arbor Bore | 1 ¹ / ₄ " (3 ³ / ₄ " adapter included) |
| Spindle | MT4 |
| Automatic Lubrication | Included |
| Automatic Feed Model | Order MAB 1300 V |

* Annular cutter drilling capacity 6" diameter up to 1" thick in carbon steel. Use TCT cutters for large diameters - see p. 64-65

Standard Equipment

- 1 Magnetic drilling machine
- 1 Heavy-duty carrying case on wheels
- 1 Arbor adapter to 3/4" Weldon (**ZAP 200**)
- 1 Safety strap
- 1 Hexagon socket screw key SW 6
- 1 Drift key MT4 (**5301**)
- 1 Operating manual
- 1 Set of allen keys
- 1 Warranty certificate



Scan to
Learn
More!

Accessories

See pages 58-68 for annular cutters and page 52 for tapping accessories.



> Annular Cutters: pages 60-68 > Accessories: pages 70-75

Tapping Accessories for MAB 1300, MAB 825, MAB 845 and CSU 100/3RL

Heavy-duty Tap Holders

- Positive, accurate driving of larger-sized taps
- No slippage or tap damage
- Tap shank square engages with square drive socket
- 3 set screws secure tap in holder



| Order Number | Morse Taper | Tap Size | Tap Shank Diameter | Tap Shank Square |
|--------------|-------------|----------|--------------------|------------------|
| 70308 | 3 | 5/8" | .480 | .366 |
| 70301 | 3 | 3/4" | .590 | .442 |
| 70302 | 3 | 7/8" | .697 | .523 |
| 70303 | 3 | 1" | .800 | .600 |
| 70304 | 3 | 1-1/8" | .896 | .672 |
| 70305 | 3 | 1-1/4" | 1.02 | .765 |
| 70307 | 3 | 1-1/2" | 1.23 | .925 |
| 70401 | 4 | 3/4" | .590 | .442 |
| 70402 | 4 | 7/8" | .697 | .523 |
| 70403 | 4 | 1" | .800 | .600 |
| 70404 | 4 | 1-1/8" | .896 | .672 |
| 70405 | 4 | 1-1/4" | 1.021 | .766 |
| 70406 | 4 | 1-3/8" | 1.108 | .831 |
| 70407 | 4 | 1-1/2" | 1.233 | .925 |
| 70408 | 4 | 1-5/8" | 1.305 | .979 |

Item ID: **GSW 444** quick-change tapping chuck with MT4 connection (for MAB 1300). Collets not included. *GSW 444 and GSS.4xx collet set shown below.*

| Order Number | Tap Collet | Shank Diameter | Square Drive |
|----------------|------------|----------------|--------------|
| GSS.420 | 20mm | 16mm | 12mm |
| GSS.422 | 22mm | 18mm | 14.5mm |
| GSS.427 | 27mm | 20mm | 16mm |
| GSS.433 | 33mm | 32mm | 20mm |
| GSS.442 | 42mm | 32mm | 24mm |



See page 72-73 for additional tapping options.

Tap Collets and Reducing Adapters



Tap Collets with 3/4" or 1-1/4" Weldon shank
all threads shown are ASA Standard (or DIN 376 for metric)

| Thread | Item ID: | Thread | Item ID: |
|----------------------|------------------|----------------------|----------------|
| 1/4 | TCM 1/4 | 10mm | ZGA 010 |
| 5/16 | TCM 5/16 | 12mm | ZGA 012 |
| 3/8 | TCM 3/8 | 14mm | ZGA 014 |
| 7/16 | TCM 7/16 | 16mm | ZGA 016 |
| 1/2 | TCM 1/2 | 18mm | ZGA 018 |
| 9/16 | TCM 9/16 | 20mm | ZGA 020 |
| 5/8 | TCM 5/8 | 22mm | ZGA 022 |
| 11/16 | TCM 11/16 | 24mm | ZGA 024 |
| 3/4 | TCM 3/4 | 27mm | ZGA 027 |
| 1-1/4" Weldon shank: | | 30mm | ZGA 030 |
| 1 | TCM 1 | 1-1/4" Weldon shank: | |
| 1-1/4 | TCM 1-1/4 | 33mm | ZGA 033 |
| | | 42mm | ZGA 042 |

Bushing – Reduces 1-1/4" Weldon shank to 3/4" Weldon shank
Item ID: **ZAP 200**



Reducing Sleeves



Item ID: **ZRH 320** for **MT 3:2**
(adapts MT3 to MT2)

Item ID: **ZRH 430** for **MT 4:3**
(adapts MT4 to MT3)

Unibroach® Large-Hole Cutting

Cut holes up to 6" dia., 10" deep!

Available in TCT Carbide, HSS, Cobalt and ARMOR-PLATED Unibroach™



Drill perfect holes without runout

- Pilot pin included up to 4" depth*
- Standard with 3/4" or 1 1/4" shank diameters
- More cutting teeth to distribute the load evenly – increase tool life and achieve faster feed rates
- Use on milling machines, drill presses, CNC and other equipment

* For sizes over 4" depth pilot pins can be purchased separately.



Automatic Magnetic Drills

AutoMAB 350 & 450

- Power feed controls drill pressure to maintain optimal RPM and feed rate
- Continuously optimized drilling pressure for extend annular cutter life and reduced cutter breakage
- Increased productivity one operator can run multiple machines
- Manual drilling mode on all models



MAB 825 V / MAB 845 V

- Drill up to 4-1/16" dia.*; Tap up to 1-1/8" dia, Ream up to 2" dia.
- Power feed controls drill pressure to maintain optimal RPM and feed rate
- Extend annular cutter life and reduce cutter breakage, reducing cutting tool cost
- Ideal for production applications
- Swivel base model available, order MAB 845 V. *The largest capacity automatic-feed, swivel base magnetic drill in the industry.*



Drill automatically



Drill manually

**AUTOMATIC FEED
BOTH UP & DOWN**

See Pages 48-49 for Full Specifications

MAB 1300 V

Largest capacity automatic magnetic drill in the industry!



**AUTOMATIC FEED
BOTH UP & DOWN**



- Drill up to 6" dia.*; Tap up to 1-5/8" dia, Ream up to 2" dia.
- Power feed controls drill pressure to maintain optimal RPM and feed rate
- Extend annular cutter life and reduce cutter breakage, while increasing productivity and profit
- Ideal for production applications



Drill automatically



Drill manually

**See Pages 50-51
for Full Specifications**



Cutter capacity
2 1/16" dia.

AIRBOR™ AB-4300

Motor and magnet are powered completely by compressed air

Pneumatic power for hazardous environments

ATEX Certified

Safe • Reliable

- Inherently safer than electromagnetic drills in hazardous atmospheres and wet environments where electricity requires "hot work permits"
- ATEX certified
- Industry's first completely air-operated magnetic drill – NO ELECTRICITY!
- Fail-safe permanent magnet is activated "on" and "off" by air pressure; in the event of a loss of air flow, the magnet will not disengage
- 1600 lbs. magnet holding strength

Drill up to 2-1/16" dia.

- Uses annular cutters up to 2-1/16" dia.
- Twist drilling capacity up to 5/8" dia.
- Powerful 1.6 HP drill motor
- Long drill stroke – up to 10 1/4"
- Pressurized coolant system lubricates cutter and reduces risk of sparking



Model AB-4300-2



With optional geared chuck adapter (Item ID: IBC 18) and extra rack (Model No. AB-4300-2R), AIRBOR™ easily converts to a standard drill press with a 7 1/2" stroke.







Pressurized lubrication system (Item ID: 9 4002 0020 N)



Scan to Learn More!



AB-4300-2R shown with extra rack up (left) and extra rack down (right).

| Cutter Capacity | Twist Drill / Countersink | Stroke (length) | Speed Range (RPM) |
|---|--|---|---|
|  |  |  |  |
| ø 2 1/16" | 5/8" | Up to 10 1/4" | 400 |

Model AB-4300-2 / AB-4300-2R Specifications

| | |
|---------------------------|----------------------------------|
| Motor Power (Pneumatic) | 1.6 HP |
| Air Consumption @ 90 PSI | 64 CFM (3/8" NPT Air Connection) |
| Hole Capacity | 2 1/16" dia. |
| No Load Speed | 400 RPM |
| Magnet Base Size | 8 3/4" L x 3 1/2" W |
| Dimensions | 13 1/2" H x 12 1/2" L x 4 3/4" W |
| Magnetic Force (1" plate) | 1600 lbs. |
| Arbor Bore | 3/4" Weldon Shank |
| Automatic Lubrication | Included |
| Stroke Length 4 7/8" | Order Model AB-4300-2 |
| Stroke Length 10 1/4" | Order Model AB-4300-2R |

Model Comparison

| AB-4300-2R | | AB-4300-2 | |
|---------------------|---------|-----------|---------|
| Drill Stroke | | | |
| w/cutters | w/chuck | w/cutters | w/chuck |
| 10 1/4" | 7 1/2" | 4 7/8" | 1 3/4" |
| Height | | | |
| closed | open | closed | open |
| 13 1/2" | 22" | 13 1/2" | 17 1/2" |
| Weight | | | |
| 43 lbs. | 20 kg | 38 lbs. | 18 kg |

➤ Annular Cutters: pages 60-68 ➤ Accessories: pages 70-75

HB 4400 for Subsea Drilling

Hydraulic for marine and construction – works underwater



Safe • Reliable

- Ideal for industrial, construction, marine and mining applications
- Drill structural steel and other metals
- Hydraulic motor safe for underwater use
- Manually operated permanent magnet with ratchet control has holding strength of 1300 lbs.

Drill up to 2-1/16" dia.





- Uses annular cutters up to 2-1/16" dia.
- Twist drilling capacity up to 1/2" dia.
- Automatic lubrication



With optional 3/4" chuck (Item ID: 602045A), this model easily converts to a standard drill press with a 3" stroke.

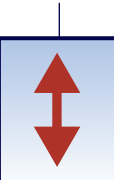

Scan to Learn More!

| | | | |
|---|---|---|---|
| Cutter Capacity | Twist Drill | Stroke (length) | Speed Range (RPM) |
|  |  |  |  |
| Ø 2 1/16" | 1/2" | Up to 3 3/4" | 0-630 |



Model HB 4400
1/2" Flush Face Quick-Connect,
Hoses not included

Model HB 4400 Specifications

| | |
|---------------------------|------------------------------|
| Motor Power (Hydraulic) | 1.5 HP |
| Weight | 48 1/2 lbs. |
| Hole Capacity | 2 1/16" dia. |
| Twist Drill Capacity | 1/2" dia. |
| No Load Speed, Variable | 0-630 RPM |
| Hydraulic Supply | Flow 6.5 GPM @ 2000 PSI |
| Magnet Base Size | 7 1/4" L x 3" W |
| Dimensions | 18 1/2" H x 12 1/2" L x 7" W |
| Magnetic Force (1" plate) | 1300 lbs. |
| Automatic Lubrication | Included |

➤ Annular Cutters: pages 60-68 ➤ Accessories: pages 70-75



Cutter capacity
4" dia.

Model 2 1345 0020 – Hydraulic

Ideal for use in Ex Zones and subsea applications

ATEX Certified

Safe • Reliable

- Hydraulic motor safe for underwater use
- Ideal for industrial, construction, marine and mining applications
- ATEX Certified EX II 2Gc IIB T5
- Drill structural steel and other metals
- Manually operated permanent magnet with lever control has holding strength of 1874 lbs.

Drill up to 4" dia.

- Uses annular cutters up to 4" dia.
- Twist drilling capacity up to 1-1/4" dia.
- Tapping capacity up to 1" dia.



Scan to
Learn More!



Model 2 1345 0020 Specifications

| | |
|-----------------------------|---|
| Motor Power (Hydraulic) | 3.4 HP |
| Weight | 50 lbs. |
| Hole Capacity | 4" dia. |
| Twist Drill Capacity | 1 1/4" dia. |
| No Load Speed, Variable | 40-250 RPM |
| Hydraulic Supply | Flow 5.3 GPM @ 2000 PSI |
| Magnet Base Size | 12 ^{13/16} " L x 7- ^{7/16} " W |
| Dimensions | 21 ^{1/2} " H x 15 ^{7/16} " L x 7 ^{3/4} " W |
| Magnetic Force (3/8" plate) | 3307 lbs. |
| Spindle | MT3 |

Pipe Clamp – Model 2 1330 8500



Optional clamp allows right angle drilling of steel, cast iron, cement and plastic pipes up to 19-1/2" dia.

Extension chains available for pipes up to 43-1/4" dia.
 Item ID: 5 1201 9030* – For pipes up to 31-1/2" (800mm)
 Item ID: 5 1201 9020* – For pipes up to 43-1/4" (1100mm)
 * 2 pieces needed for one clamp

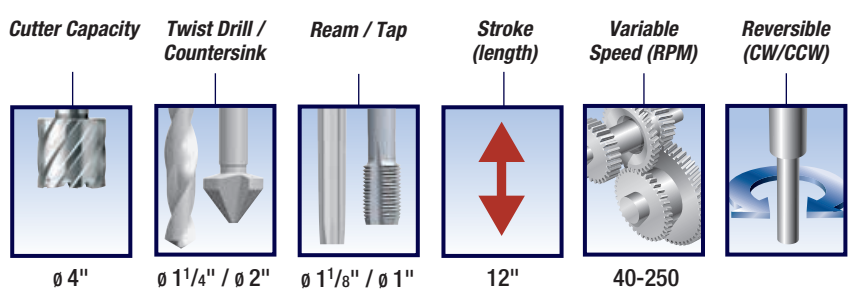

Standard Equipment includes hydraulic hose set, coolant bottle, arbor adapter to 3/4" Weldon, arbor adapter to 1-1/4" Weldon, safety chain, drift key, allen keys and carrying case.

➤ Annular Cutters: pages 60-68 ➤ Accessories: pages 70-75

Underwater Tools

Hydraulic and air-powered tools for use in subsea applications

Over 50 models of underwater tools available visit csunitec.com/underwater learn more about CS Unitec's wide range of underwater tools

Grinders - Hydraulic

- 1 1580 0060 N Underwater Hydraulic Horizontal Grinder, 1.3HP, 7000 RPM, Twist throttle, straight grinding wheels
- 1 1585 0010 Underwater Hydraulic Angle Grinder, 1.3HP, 5500 RPM, Lever throttle, grinding wheels up to 7"
- 1 5080 0020 Underwater Hydraulic Peanut Die Grinder, 1.0 HP, 11,500 RPM, Lever throttle, 1/4" collet
- 1 2060 0010 Underwater Hydraulic Vertical Grinder, 4.75 HP, 3600 RPM, grinding wheels up to 9"

Rotary Hammer Drills - Hydraulic and Pneumatic

- 2 2404 0030 Underwater Air Rotary Hammer Drill, SDS Plus, 1" cap. in concrete, 0-3000 BPM, .5 HP, 90 PSI / 21 CFM
- 2 2417 0010 Underwater Air Rotary Hammer Drill, SDS Max, 2" cap. in concrete, 0-2500 BPM, 1.2 HP, 90 PSI / 21 CFM
- 2 2426 0010 Underwater Hydraulic Rotary Hammer Drill, SDS Plus, 1" cap. in concrete, 0-3400 BPM, .8 HP; includes built-in pressure reducing valve
- 2 2418 0020 Underwater Hydraulic Rotary Hammer Drill, SDS Max, 2" cap. in concrete, 2500 BPM, 1.75 HP

Core Drills - Hydraulic and Pneumatic

- 2 1317 0030 Underwater Hydraulic Core Drill, 6" max. dia., 3.6 HP, 380/900/1800 RPM
- 2 1335 0010 Underwater Pneumatic Core Drill, 6" max. dia., 3.8 HP, 300/700/1350 RPM

Impact Wrenches - Hydraulic and Pneumatic

- 6 1316 0070 3/4" Air Impact Wrench, 1-1/8" (M 30) max. bolt size, 995 ft-lbs. torque
- 6 1316 0060 1" Air Impact Wrench, 1-1/8" (M 30) max. bolt size, 995 ft-lbs. torque
- 6 1515 0010 3/4" Hydraulic Impact Wrench, 1" (M 27) max. bolt size, 1220 ft-lbs. torque
- 6 1520 0010 1" Hydraulic Impact Wrench, 1-3/8" (M 36) max. bolt size, 1840 ft-lbs.



Caution: User must follow all appropriate safety regulations when choosing a tool for their particular working environment.



Woodboring Drills - Pneumatic See page 81

Circular Saws - Hydraulic See page 110-111

Reciprocating Saws - Hydraulic and Air See page 112-113

Portable Band Saws - Air, Electric, Hydraulic See page 114-115

Hacksaws - Hydraulic See page 116-118



Underwater Chainsaws

Hydraulic and air-powered tools for use in subsea or other applications

Fast, accurate cutting on the job site! Our saws can be used as hand-held tools or with an assortment of clamps for pipe and other materials. Our complete saw line includes pneumatic, electric and hydraulic-powered tools, saw blades and accessories.

- **Fast, consistent & accurate cutting**
- **Carbide tipped and ripping saw chains for faster, longer, and easier cutting**
- **Superior power to weight ratio to cut through tough materials**



ATEX Certified

ATEX certified models are available.



Hydraulic Chainsaws

- 5 1030 0010 17" Hydraulic Chain Saw With Chain Brake
10 HP, 12 GPM @ 2000 PSI, 5000 RPM
- 5 1030 0020 21" Hydraulic Chain Saw With Chain Brake
10 HP, 12 GPM @ 2000 PSI, 5000 RPM
- 5 1030 0040 25" Hydraulic Chain Saw With Chain Brake
10 HP, 12 GPM @ 2000 PSI, 5000 RPM



Pneumatic Chainsaws

- 5 1008 0020 17" Pneumatic Chain Saw
4 HP, 92 CFM @ 90 PSI, 3/4" NPT (ID)
- 5 1008 0030 21" Pneumatic Chain Saw
4 HP, 92 CFM @ 90 PSI, 3/4" NPT (ID)
- 5 1008 0040 25" Pneumatic Chain Saw
4 HP, 92 CFM @ 90 PSI, 3/4" NPT (ID)
- 5 1028 0010 17" Pneumatic Chain Saw With Chain Brake
4 HP, 92 CFM @ 90 PSI, 3/4" NPT (ID)
- 5 1028 0020 21" Pneumatic Chain Saw With Chain Brake
4 HP, 92 CFM @ 90 PSI, 3/4" NPT (ID)
- 5 1028 0040 25" Pneumatic Chain Saw With Chain Brake
4 HP, 92 CFM @ 90 PSI, 3/4" NPT (ID)



Alternate / Custom blade sizes available by request

Underwater Hydraulic Drills



Hydraulic-powered tools for use in subsea applications

Engineered for extreme subsea conditions, these hydraulic drills deliver reliable power, precision, and safety where conventional equipment can't operate.



| Model 2 3060 0010 | Specifications |
|-------------------------|-----------------------------------|
| Motor Power (Hydraulic) | 2.15 HP |
| Speed (Free) | 280 RPM |
| Hole Capacity in Steel | 1-1/4" dia. |
| Max Drilling Depth | 472" |
| Reversible | Yes |
| Operating Pressure | 90-140 bar (1300-2030 PSI) |
| Hydraulic Supply | 2.6-11.9 GPM @ 1300-2030 PSI |
| Weight | 18.74 lbs. |
| Spindle | MT3 (optional IBC 21 Drill Chuck) |



| Model 2 1360 0010 | Specifications |  |
|-------------------------|-------------------------|---|
| Motor Power (Hydraulic) | 2.7 HP | |
| Speed (Free) | 1,120 RPM | |
| Speed (Load) | 900 RPM | |
| Hole Capacity in Steel | 1/2" dia. | |
| Hole Capacity in Wood | 1-1/4" dia. | |
| Shank | Geared chuck up to 1/2" | |
| Operating Pressure | 140 bar | |
| Hydraulic Supply | 4-8 GPM @ 2000 PSI | |
| Weight | 18 lbs. | |
| Chuck | 1/2" Drill Chuck | |



Unibroach® Annular Cutters

High-speed steel for drilling 3x faster than twist drills



**Annular Cutter
Recommended
Revolutions Per Minute**
Recommended Feed Rate:
.002 - .004 inches per revolution

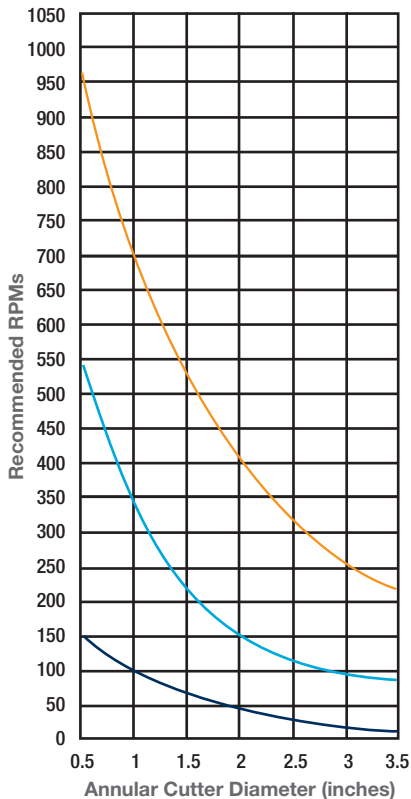

Annular Cutters are the standard hole-making drills in the industry. Ideal for heavy-duty use on-site or in the shop, our HSS Unibroach™ cutters are available in the following sizes: **Larger diameter & Longer Lengths available upon request**

| Drill Depth | 1" | 2" | 3" | 4" | 6" | 8" |
|-------------|-------------------------|-------------------------|-------------------------|-----------------------|-----------------------|-----------------------|
| Diameter | ø 7/16" to ø 5/8" | ø 7/16" to ø 5/8" | ø 3/4" to ø 5/8"+ | ø 3/4" to ø 6"+ | ø 3/4" to ø 6"+ | ø 3/4" to ø 6"+ |

Metric, Stack and 32nd Size Cutters also Available. Every annular cutter up to 4" DOC includes a pilot pin.*

- CNC precision ground for fast penetration, accuracy and long life
- Flutes run the length of the cutter for efficient chip clearance, increased drilling productivity and decreased cutter breakage
- Drill holes 3 times faster than twist drills
- Produce reamed-quality, burr-free holes and solid slugs
- Reduce machine size and weight
- Cutting edges are resharpenable
- Eliminate time-consuming, costly pilot holes and step drilling

HSS Cutters must be used with lubricant. See page 70 for CS Unitec lubricants and cutting oil.



Aluminum
200 ft./min.
Mild Steel (Carbon)
80 ft./min.
High Tensile Steel (Stainless)
30 ft./min.



Scan to Learn More!

HSS Annular Cutter kits are also available



* Pilot pins supplied with annular cutters up to 4" DOC. Other pilot pins can be purchased separately.

Unibroach® Stack Cutters are available in diameters from 9/16" to 1 1/8" in 1", 2" and 3" depths. Drill multiple layers of steel without stopping to remove the center slug. Please contact us or consult our price list for more information.

6-Series HSS Metric & Stack Sizes Available

| 1" Depth | | 2" Depth | | 3" Depth* | |
|----------|----------|----------|----------|-----------|----------|
| Item ID: | Diameter | Item ID: | Diameter | Item ID: | Diameter |
| 6-1-114 | 7/16" | 6-1-214 | 7/16" | N/A | |
| 6-1-116 | 1/2" | 6-1-216 | 1/2" | N/A | |
| 6-1-118 | 9/16" | 6-1-218 | 9/16" | N/A | |
| 6-1-120 | 5/8" | 6-1-220 | 5/8" | N/A | |
| 6-1-122 | 11/16" | 6-1-222 | 11/16" | 6-1-322 | 11/16" |
| 6-1-124 | 3/4" | 6-1-224 | 3/4" | 6-1-324 | 3/4" |
| 6-1-126 | 13/16" | 6-1-226 | 13/16" | 6-1-326 | 13/16" |
| 6-1-128 | 7/8" | 6-1-228 | 7/8" | 6-1-328 | 7/8" |
| 6-1-130 | 15/16" | 6-1-230 | 15/16" | 6-1-330 | 15/16" |
| 6-1-132 | 1" | 6-1-232 | 1" | 6-1-332 | 1" |
| 6-1-134 | 1-1/16" | 6-1-234 | 1-1/16" | 6-1-334 | 1-1/16" |
| 6-1-136 | 1-1/8" | 6-1-236 | 1-1/8" | 6-1-336 | 1-1/8" |
| 6-1-138 | 1-3/16" | 6-1-238 | 1-3/16" | 6-1-338 | 1-3/16" |
| 6-1-140 | 1-1/4" | 6-1-240 | 1-1/4" | 6-1-340 | 1-1/4" |
| 6-1-142 | 1-5/16" | 6-1-242 | 1-5/16" | 6-1-342 | 1-5/16" |
| 6-1-144 | 1-3/8" | 6-1-244 | 1-3/8" | 6-1-344 | 1-3/8" |
| 6-1-146 | 1-7/16" | 6-1-246 | 1-7/16" | 6-1-346 | 1-7/16" |
| 6-1-148 | 1-1/2" | 6-1-248 | 1-1/2" | 6-1-348 | 1-1/2" |
| 6-1-150 | 1-9/16" | 6-1-250 | 1-9/16" | 6-1-350 | 1-9/16" |
| 6-1-152 | 1-5/8" | 6-1-252 | 1-5/8" | 6-1-352 | 1-5/8" |
| 6-1-154 | 1-11/16" | 6-1-254 | 1-11/16" | 6-1-354 | 1-11/16" |
| 6-1-156 | 1-3/4" | 6-1-256 | 1-3/4" | 6-1-356 | 1-3/4" |
| 6-1-158 | 1-13/16" | 6-1-258 | 1-13/16" | 6-1-358 | 1-13/16" |
| 6-1-160 | 1-7/8" | 6-1-260 | 1-7/8" | 6-1-360 | 1-7/8" |
| 6-1-162 | 1-15/16" | 6-1-262 | 1-15/16" | 6-1-362 | 1-15/16" |
| 6-1-164 | 2" | 6-1-264 | 2" | 6-1-364 | 2" |
| 6-1-166 | 2-1/16" | 6-1-266 | 2-1/16" | 6-1-366 | 2-1/16" |
| 6-1-168 | 2-1/8" | 6-1-268 | 2-1/8" | 6-1-368 | 2-1/8" |
| 6-1-170 | 2-3/16" | 6-1-270 | 2-3/16" | 6-1-370 | 2-3/16" |
| 6-1-172 | 2-1/4" | 6-1-272 | 2-1/4" | 6-1-372 | 2-1/4" |
| 6-1-174 | 2-5/16" | 6-1-274 | 2-5/16" | 6-1-374 | 2-5/16" |
| 6-1-176 | 2-3/8" | 6-1-276 | 2-3/8" | 6-1-376 | 2-3/8" |
| 6-1-178 | 2-7/16" | 6-1-278 | 2-7/16" | 6-1-378 | 2-7/16" |
| 6-1-180 | 2-1/2" | 6-1-280 | 2-1/2" | 6-1-380 | 2-1/2" |
| 6-1-182 | 2-9/16" | 6-1-282 | 2-9/16" | 6-1-382 | 2-9/16" |
| 6-1-184 | 2-5/8" | 6-1-284 | 2-5/8" | 6-1-384 | 2-5/8" |
| 6-1-186 | 2-11/16" | 6-1-286 | 2-11/16" | 6-1-386 | 2-11/16" |
| 6-1-188 | 2-3/4" | 6-1-288 | 2-3/4" | 6-1-388 | 2-3/4" |
| 6-1-190 | 2-13/16" | 6-1-290 | 2-13/16" | 6-1-390 | 2-13/16" |
| 6-1-192 | 2-7/8" | 6-1-292 | 2-7/8" | 6-1-392 | 2-7/8" |
| 6-1-194 | 2-15/16" | 6-1-294 | 2-15/16" | 6-1-394 | 2-15/16" |
| 6-1-196 | 3" | 6-1-296 | 3" | 6-1-396 | 3" |
| 6-1-198 | 3-1/16" | 6-1-298 | 3-1/16" | 6-1-398 | 3-1/16" |
| 6-1-1100 | 3-1/8" | 6-1-2100 | 3-1/8" | 6-1-3100 | 3-1/8" |
| 6-1-1102 | 3-3/16" | 6-1-2102 | 3-3/16" | 6-1-3102 | 3-3/16" |
| 6-1-1104 | 3-1/4" | 6-1-2104 | 3-1/4" | 6-1-3104 | 3-1/4" |
| 6-1-1106 | 3-5/16" | 6-1-2106 | 3-5/16" | 6-1-3106 | 3-5/16" |
| 6-1-1108 | 3-3/8" | 6-1-2108 | 3-3/8" | 6-1-3108 | 3-3/8" |
| 6-1-1110 | 3-7/16" | 6-1-2110 | 3-7/16" | 6-1-3110 | 3-7/16" |
| 6-1-1112 | 3-1/2" | 6-1-2112 | 3-1/2" | 6-1-3112 | 3-1/2" |
| 6-1-1114 | 3-9/16" | 6-1-2114 | 3-9/16" | 6-1-3114 | 3-9/16" |
| 6-1-1116 | 3-5/8" | 6-1-2116 | 3-5/8" | 6-1-3116 | 3-5/8" |
| 6-1-1118 | 3-11/16" | 6-1-2118 | 3-11/16" | 6-1-3118 | 3-11/16" |
| 6-1-1120 | 3-3/4" | 6-1-2120 | 3-3/4" | 6-1-3120 | 3-3/4" |
| 6-1-1122 | 3-13/16" | 6-1-2122 | 3-13/16" | 6-1-3122 | 3-13/16" |
| 6-1-1124 | 3-7/8" | 6-1-2124 | 3-7/8" | 6-1-3124 | 3-7/8" |
| 6-1-1126 | 3-15/16" | 6-1-2126 | 3-15/16" | 6-1-3126 | 3-15/16" |
| 6-1-1128 | 4" | 6-1-2128 | 4" | 6-1-3128 | 4" |



Shank size:

**3/4" for cutters up to 3" dia.
1-1/4" for cutters 3-1/16 and larger.**

Pilot pin included with every annular cutter up to 4" DOC

Cutter Kits

Each HSS steel cutter kit comes with the following: 9/16", 11/16", 13/16", 15/16", 1-1/16", pilot pins & carrying case.

| Item ID: | Description |
|----------|---------------------|
| 6-1-001 | 1" depth Cutter Kit |
| 6-1-002 | 2" depth Cutter Kit |

Pilot Pins for 6-Series

| Item ID: | Description |
|--------------------------|---------------------------------|
| For 3/4" Shanks | |
| 7-3-102 | 7/16" - 3" dia., 1" depth |
| 7-3-202 | 7/16" - 3" dia., 2" depth |
| 7-3-302 | 3/4" - 3" dia., 3" depth |
| For 1-1/4" Shanks | |
| 7-3-1002 | 3-1/16" - 5-1/8" dia., 1" depth |
| 7-3-2002 | 3-1/16" - 5-1/8" dia., 2" depth |
| 7-3-3002 | 3-1/16" - 5-1/8" dia., 3" depth |

Option for Cutters 3" and 4" Depth

| | |
|---------|--|
| 7-3-402 | 2-piece pin for 3" and 4" depth cutters with 8mm pilot hole. |
|---------|--|

Option for Cutters 6" and 8" Depth

| | |
|-----------|---|
| 9-3-602 C | Pin for 6" depth cutters with 8mm pilot hole. |
| 9-3-802 C | Pin for 8" depth cutters with 8mm pilot hole. |

* Cutters with 3" depth have an 8mm dia. pilot hole.



Scan or visit
www.csunitec.com to
see all sizes available

Metric, Strack, 32nd size cutters, and 4", 6", 8" depth HSS annular cutters also available. Large diameter & custom sizes available with low MOQ. Call today to speak to a CS Unitec specialist

➤ See pages 70-75 for Drill Accessories

Unibroach[®] Annular Cutters

TiAlN Carbide coating for up to 4x tool life, less friction and more power

Less Friction = Less Heat = More Holes!

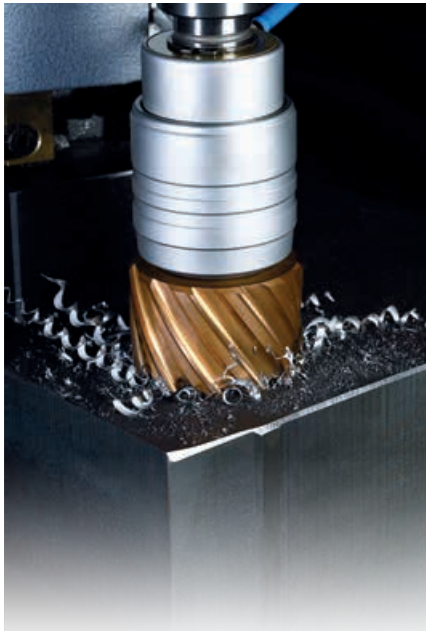

ARMOR-PLATED Unibroach[™] Cutters, at 90Rc hardness, are the state-of-the-art in hole cutting technology. They multiply service life, reduce cost and increase productivity.

ARMOR-PLATED Unibroach[™] cutters are available in the following sizes:

| Drill Depth | 1" | 2" | 3" |
|-------------|-----------------------|-----------------------|----------------------|
| Diameter | ø 7/16" to ø 1-5/8" + | ø 7/16" to ø 1-5/8" + | ø 3/4" to ø 1-5/8" + |

Metric, Stack and 32nd Size Cutters also Available.
Every annular cutter up to 4" DOC includes a pilot pin.*

- 3 to 4 times longer tool life with TiAlN Carbide coating
- Drill with less friction and more power
- Withstands higher working temperatures – up to 1480°F (800°C)
- Dry drilling or lubricating with water simplifies working conditions and cleanup
- Prevents cold weld – metal chips do not adhere to the cutter
- Ideal for structural steel and hard metal
- 3/4" dia. shank, 1 1/4" dia. shank on cutters larger than 3" diameter

After the TiAlN Carbide coating is worn, lubricate with cutting oil



Scan to Learn More!

Annular Cutter Recommended Revolutions Per Minute
Recommended Feed Rate:
.002 - .004 inches per revolution

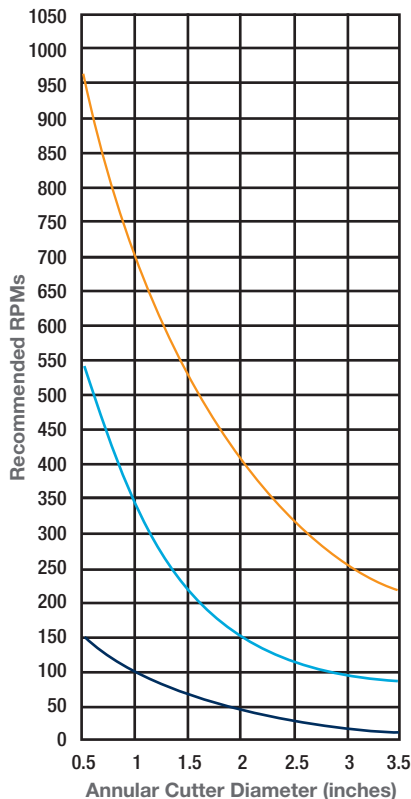

Aluminum
200 ft./min.

Mild Steel (Carbon)
80 ft./min.

High Tensile Steel (Stainless)
30 ft./min.



Pilot pin included with every annular cutter up to 4" DOC



ARMOR-PLATED Unibroach[™] TiAlN Carbide-Coated Annular Cutter Starter Kits also available

8-Series ARMOR-PLATED TiAIN

ARMOR-PLATED = Less Friction = Less Heat = More Holes!
Increase tool life and achieve faster feed rates



Shank size: 3/4" up to 3" dia.

ARMOR-PLATED Unibroach™ Cutters, at 90Rc hardness, are the state-of-the-art in hole cutting technology. They multiply service life, reduce cost and increase productivity.



| 1" Depth | |
|-----------|----------|
| Item ID: | Diameter |
| 8-1-114 T | 7/16" |
| 8-1-116 T | 1/2" |
| 8-1-118 T | 9/16" |
| 8-1-120 T | 5/8" |
| 8-1-122 T | 11/16" |
| 8-1-124 T | 3/4" |
| 8-1-126 T | 13/16" |
| 8-1-128 T | 7/8" |
| 8-1-130 T | 15/16" |
| 8-1-132 T | 1" |
| 8-1-134 T | 1-1/16" |
| 8-1-136 T | 1-1/8" |
| 8-1-138 T | 1-3/16" |
| 8-1-140 T | 1-1/4" |
| 8-1-142 T | 1-5/16" |
| 8-1-144 T | 1-3/8" |
| 8-1-146 T | 1-7/16" |
| 8-1-148 T | 1-1/2" |
| 8-1-150 T | 1-9/16" |
| 8-1-152 T | 1-5/8" |
| 8-1-154 T | 1-11/16" |
| 8-1-156 T | 1-3/4" |
| 8-1-158 T | 1-13/16" |
| 8-1-160 T | 1-7/8" |
| 8-1-162 T | 1-15/16" |
| 8-1-164 T | 2" |
| 8-1-166 T | 2-1/16" |

| 2" Depth | |
|-----------|----------|
| Item ID: | Diameter |
| 8-1-214 T | 7/16" |
| 8-1-216 T | 1/2" |
| 8-1-218 T | 9/16" |
| 8-1-220 T | 5/8" |
| 8-1-222 T | 11/16" |
| 8-1-224 T | 3/4" |
| 8-1-226 T | 13/16" |
| 8-1-228 T | 7/8" |
| 8-1-230 T | 15/16" |
| 8-1-232 T | 1" |
| 8-1-234 T | 1-1/16" |
| 8-1-236 T | 1-1/8" |
| 8-1-238 T | 1-3/16" |
| 8-1-240 T | 1-1/4" |
| 8-1-242 T | 1-5/16" |
| 8-1-244 T | 1-3/8" |
| 8-1-246 T | 1-7/16" |
| 8-1-248 T | 1-1/2" |
| 8-1-250 T | 1-9/16" |
| 8-1-252 T | 1-5/8" |
| 8-1-254 T | 1-11/16" |
| 8-1-256 T | 1-3/4" |
| 8-1-258 T | 1-13/16" |
| 8-1-260 T | 1-7/8" |
| 8-1-262 T | 1-15/16" |
| 8-1-264 T | 2" |
| 8-1-266 T | 2-1/16" |

| 3" Depth* | |
|-----------|----------|
| Item ID: | Diameter |
| N/A | |
| N/A | |
| N/A | |
| N/A | |
| N/A | |
| 8-1-324 T | 3/4" |
| 8-1-326 T | 13/16" |
| 8-1-328 T | 7/8" |
| 8-1-330 T | 15/16" |
| 8-1-332 T | 1" |
| 8-1-334 T | 1-1/16" |
| 8-1-336 T | 1-1/8" |
| 8-1-338 T | 1-3/16" |
| 8-1-340 T | 1-1/4" |
| 8-1-342 T | 1-5/16" |
| 8-1-344 T | 1-3/8" |
| 8-1-346 T | 1-7/16" |
| 8-1-348 T | 1-1/2" |
| 8-1-350 T | 1-9/16" |
| 8-1-352 T | 1-5/8" |
| 8-1-354 T | 1-11/16" |
| 8-1-356 T | 1-3/4" |
| 8-1-358 T | 1-13/16" |
| 8-1-360 T | 1-7/8" |
| 8-1-362 T | 1-15/16" |
| 8-1-364 T | 2" |
| 8-1-366 T | 2-1/16" |

Pilot pin included with every annular cutter up to 4" DOC

ARMOR-PLATED Cutter Kits

Each armor-plated cutter kit comes with the following: 9/16", 11/16", 13/16", 15/16", 1-1/16", pilot pins & carrying case.

| Item ID: | Description |
|-----------|---------------------|
| 8-1-001 T | 1" depth Cutter Kit |
| 8-1-002 T | 2" depth Cutter Kit |

Pilot Pins for 8-Series

| Item ID: | Description |
|------------------------|---------------------------|
| For 3/4" Shanks | |
| 7-3-102 | 7/16" - 3" dia., 1" depth |
| 7-3-202 | 7/16" - 3" dia., 2" depth |
| 7-3-302 | 3/4" - 3" dia., 3" depth |

Option for Cutters 3" and 4" Depth

| | |
|---------|--|
| 7-3-402 | 2-piece pin for 3" and 4" depth cutters with 8mm pilot hole. |
|---------|--|

* Cutters with 3" depth have an 8mm dia. pilot hole.

3" + Diameter Cutters

Metric and larger diameter cutters available on request.

ARMOR-PLATED Unibroach™ TiAIN Carbide-Coated Cutters:

- Drill with less friction and more power
- Withstand higher working temperatures – up to 1480°F (800°C)
- Dry drill or lubricate with water to simplify working conditions and cleanup**
- Prevent cold weld – metal chips do not adhere to the cutter
- Are ideal for structural steel and hard metal

** After the TiAIN Carbide coating is worn, lubricate with cutting oil

Metric Sizes Available!



Scan or visit
www.csunitec.com to
 see all sizes available

➤ See pages 70-75 for Drill Accessories

Unibroach® Annular Cutters

TCT Carbide Hornet – tungsten carbide-tipped for high-speed cutting



- Use high-speed RPM for best results and faster holemaking
- Ideal for drilling steel with rust or paint and bolting applications
- Will outlast High-speed Steel cutters
- Leaves a burr-free finished hole
- Available in all sizes (fractional and metric)
- 2 flats
- 3/4" or 1 1/4" shank
- Pilot pins supplied with annular cutters up to 4" DOC



Closeup of tungsten-carbide teeth.

| Drill Depth | 1" | 1-3/8" | 2-3/8" | 3-3/8" | 4" | 6" | 8" | 10" |
|-------------|--------------------------|----------------------------|---------------------------|---------------------------|-----------------------|-------------------------|-------------------------|-------------------------|
| Diameter | Ø 1/2" to Ø 1-1/2" | Ø 1-9/16" to Ø 2" | Ø 1/2" to Ø 5-1/8"+ | Ø 3/4" to Ø 5-1/8"+ | Ø 3/4" to Ø 6"+ | Ø 13/16" to Ø 6"+ | Ø 13/16" to Ø 6"+ | Ø 13/16" to Ø 6"+ |

Metric, Stack and 32nd Size Cutters also Available.
Every annular cutter up to 4" DOC includes a pilot pin.*



*Armor plating
available upon
request.*



**Scan to
Learn More!**

9-Series Annular Cutter Recommended RPM Rates

| Cutter Size | Stainless & Alloy Steel | Mild Steel | Iron Plate |
|---------------------|----------------------------|---------------|---------------|
| | RPM | RPM | RPM |
| 1/2" - 5/8" | 500 - 800 | 600 - 1000 | 800 - 1200 |
| 11/16" - 13/16" | 400 - 640 | 480 - 800 | 640 - 960 |
| 7/8" - 15/16" | 330 - 530 | 400 - 660 | 530 - 800 |
| 1" - 1 3/16" | 270 - 420 | 320 - 530 | 420 - 640 |
| 1 1/4" - 1 3/8" | 230 - 370 | 270 - 460 | 360 - 550 |
| 1 7/16" - 1 9/16" | 200 - 320 | 240 - 400 | 320 - 480 |
| 1 5/8" - 1 3/4" | 180 - 280 | 210 - 350 | 280 - 420 |
| 1 13/16" - 2" | 160 - 260 | 190 - 320 | 260 - 380 |
| 2 1/16" - 2 3/16" | 145 - 230 | 170 - 290 | 230 - 350 |
| 2 1/4" - 2 3/8" | 135 - 210 | 160 - 270 | 210 - 320 |
| 2 7/16" - 2 9/16" | 120 - 200 | 150 - 250 | 200 - 300 |
| 2 5/8" - 2 3/4" | 115 - 180 | 140 - 230 | 180 - 270 |
| 2 13/16" - 2 15/16" | 110 - 170 | 130 - 210 | 170 - 260 |
| 3" - 3 1/8" | 100 - 160 | 120 - 200 | 160 - 240 |
| 3 3/16" - 3 3/8" | 95 - 150 | 115 - 190 | 150 - 230 |
| 3 7/16" - 3 9/16" | 90 - 140 | 110 - 180 | 140 - 210 |
| 3 5/8" - 3 3/4" | 85 - 135 | 105 - 170 | 135 - 200 |
| 3 13/16" - 3 15/16" | 80 - 130 | 95 - 160 | 130 - 195 |
| 4" - 4 5/16" | 70 - 120 | 90 - 145 | 120 - 170 |
| 4 3/8" - 4 3/4" | 70 - 110 | 80 - 135 | 110 - 160 |
| 4 13/16" - 5 1/8" | 65 - 100 | 75 - 125 | 100 - 150 |

9-Series - TCT Carbide Hornet

Metric & Stack Sizes Available

1" Depth

| Item ID: | Diameter |
|-----------|----------|
| 9-1-116 C | 1/2" |
| 9-1-118 C | 9/16" |
| 9-1-120 C | 5/8" |
| 9-1-122 C | 11/16" |
| 9-1-124 C | 3/4" |
| 9-1-126 C | 13/16" |
| 9-1-128 C | 7/8" |
| 9-1-130 C | 15/16" |
| 9-1-132 C | 1" |

1-3/8" Depth

| Item ID: | Diameter |
|-----------|----------|
| 9-1-150 C | 1-9/16" |
| 9-1-152 C | 1-5/8" |
| 9-1-154 C | 1-11/16" |
| 9-1-156 C | 1-3/4" |
| 9-1-158 C | 1-13/16" |
| 9-1-160 C | 1-7/8" |
| 9-1-162 C | 1-15/16" |
| 9-1-164 C | 2" |



Shank size:

3/4" for cutters up to 3" dia.
1-1/4" for cutters 3-1/16 and larger dia.

Pilot pin included with every annular cutter up to 4" DOC

2-3/8" Depth

| Item ID: | Diameter |
|-----------|----------|
| 9-1-216 C | 1/2" |
| 9-1-218 C | 9/16" |
| 9-1-220 C | 5/8" |
| 9-1-222 C | 11/16" |
| 9-1-224 C | 3/4" |
| 9-1-226 C | 13/16" |
| 9-1-228 C | 7/8" |
| 9-1-230 C | 15/16" |
| 9-1-232 C | 1" |
| 9-1-234 C | 1-1/16" |
| 9-1-236 C | 1-1/8" |
| 9-1-238 C | 1-3/16" |
| 9-1-240 C | 1-1/4" |
| 9-1-242 C | 1-5/16" |
| 9-1-244 C | 1-3/8" |
| 9-1-246 C | 1-7/16" |
| 9-1-248 C | 1-1/2" |
| 9-1-250 C | 1-9/16" |
| 9-1-252 C | 1-5/8" |
| 9-1-254 C | 1-11/16" |
| 9-1-256 C | 1-3/4" |
| 9-1-258 C | 1-13/16" |
| 9-1-260 C | 1-7/8" |
| 9-1-262 C | 1-15/16" |
| 9-1-264 C | 2" |

| Item ID: | Diameter |
|-----------|----------|
| 9-1-266 C | 2-1/16" |
| 9-1-268 C | 2-1/8" |
| 9-1-270 C | 2-3/16" |
| 9-1-272 C | 2-1/4" |
| 9-1-274 C | 2-5/16" |
| 9-1-276 C | 2-3/8" |
| 9-1-278 C | 2-7/16" |
| 9-1-280 C | 2-1/2" |
| 9-1-282 C | 2-9/16" |
| 9-1-284 C | 2-5/8" |
| 9-1-286 C | 2-11/16" |
| 9-1-288 C | 2-3/4" |
| 9-1-290 C | 2-13/16" |
| 9-1-292 C | 2-7/8" |
| 9-1-294 C | 2-15/16" |
| 9-1-296 C | 3" |
| 9-1-298 C | 3-1/16" |
| 9-1-300 C | 3-1/8" |
| 9-1-302 C | 3-3/16" |
| 9-1-304 C | 3-1/4" |
| 9-1-306 C | 3-5/16" |
| 9-1-308 C | 3-3/8" |
| 9-1-310 C | 3-7/16" |
| 9-1-312 C | 3-1/2" |

| Item ID: | Diameter |
|-----------|----------|
| 9-1-214 C | 3-9/16" |
| 9-1-216 C | 3-5/8" |
| 9-1-218 C | 3-11/16" |
| 9-1-220 C | 3-3/4" |
| 9-1-222 C | 3-13/16" |
| 9-1-224 C | 3-7/8" |
| 9-1-226 C | 3-15/16" |
| 9-1-228 C | 4" |
| 9-1-230 C | 4-1/16" |
| 9-1-232 C | 4-1/8" |
| 9-1-234 C | 4-3/16" |
| 9-1-236 C | 4-1/4" |
| 9-1-238 C | 4-5/16" |
| 9-1-240 C | 4-3/8" |
| 9-1-242 C | 4-7/16" |
| 9-1-244 C | 4-1/2" |
| 9-1-246 C | 4-9/16" |
| 9-1-248 C | 4-5/8" |
| 9-1-250 C | 4-11/16" |
| 9-1-252 C | 4-3/4" |
| 9-1-254 C | 4-13/16" |
| 9-1-256 C | 4-7/8" |
| 9-1-258 C | 4-15/16" |
| 9-1-260 C | 5" |
| 9-1-262 C | 5-1/16" |
| 9-1-264 C | 5-1/8" |

Cutter Kits

Each hornet carbide cutter kit comes with the following: 9/16", 11/16", 13/16", 15/16", 1-1/16", pilot pins & carrying case.

| Item ID: | Description |
|-----------|-------------------------|
| 9-1-001 C | 1" depth Cutter Kit |
| 9-1-002 C | 2-3/8" depth Cutter Kit |

****We also stock Metric Carbide cutters. Please call us for pricing and delivery. Larger diameters and special sizes are available upon request.**

Pilot Pins for 9-Series

| Item ID: | Description |
|--------------------------|-------------------------------------|
| For 3/4" Shanks | |
| 9-3-101 C | 1/2" - 1-1/2" dia., 1" depth |
| 9-3-102 C | 1-9/16" - 2" dia., 1-3/8" depth |
| 9-3-202 C | 1/2" - 3" dia., 2-3/8" depth |
| 9-3-302 C | 3/4" - 3" dia., 3-3/8" depth |
| For 1-1/4" Shanks | |
| 9-3-202A C | 3-1/16" - 5-1/8" dia., 2-3/8" depth |
| 9-3-302 C-L | 3-1/16" - 5-1/8" dia., 3-3/8" depth |

Option for Cutters 3-3/8" and 4" Depth

| Item ID: | Description |
|----------|--|
| 7-3-402 | 2-piece pin for 3-3/8" and 4" depth cutters with 8mm pilot hole. |

Option for Cutters 6" and 8" Depth

| | |
|-----------|---|
| 9-3-602 C | Pin for 6" depth cutters with 8mm pilot hole. |
| 9-3-802 C | Pin for 8" depth cutters with 8mm pilot hole. |



Scan or visit www.csunitec.com to see all sizes available

4", 6", 8", 10" depth TCT annular cutters also available.

➤ See pages 70-75 for Drill Accessories

Unibroach® 7-Series Cobalt Cutters

1" Depth

| Item ID: | Diameter |
|----------|----------|
| 7-1-114 | 7/16" |
| 7-1-116 | 1/2" |
| 7-1-118 | 9/16" |
| 7-1-120 | 5/8" |
| 7-1-122 | 11/16" |
| 7-1-124 | 3/4" |
| 7-1-126 | 13/16" |
| 7-1-128 | 7/8" |
| 7-1-130 | 15/16" |
| 7-1-132 | 1" |
| 7-1-134 | 1-1/16" |
| 7-1-136 | 1-1/8" |
| 7-1-138 | 1-3/16" |
| 7-1-140 | 1-1/4" |
| 7-1-142 | 1-5/16" |
| 7-1-144 | 1-3/8" |
| 7-1-146 | 1-7/16" |
| 7-1-148 | 1-1/2" |
| 7-1-150 | 1-9/16" |
| 7-1-152 | 1-5/8" |
| 7-1-154 | 1-11/16" |
| 7-1-156 | 1-3/4" |
| 7-1-158 | 1-13/16" |
| 7-1-160 | 1-7/8" |
| 7-1-162 | 1-15/16" |
| 7-1-164 | 2" |
| 7-1-166 | 2-1/16" |
| 7-1-168 | 2-1/8" |
| 7-1-170 | 2-3/16" |
| 7-1-172 | 2-1/4" |
| 7-1-174 | 2-5/16" |
| 7-1-176 | 2-3/8" |
| 7-1-178 | 2-7/16" |
| 7-1-180 | 2-1/2" |
| 7-1-182 | 2-9/16" |
| 7-1-184 | 2-5/8" |
| 7-1-186 | 2-11/16" |
| 7-1-188 | 2-3/4" |
| 7-1-190 | 2-13/16" |
| 7-1-192 | 2-7/8" |
| 7-1-194 | 2-15/16" |
| 7-1-196 | 3" |
| 7-1-198 | 3-1/16" |
| 7-1-1100 | 3-1/8" |
| 7-1-1102 | 3-3/16" |
| 7-1-1104 | 3-1/4" |
| 7-1-1106 | 3-5/16" |
| 7-1-1108 | 3-3/8" |
| 7-1-1110 | 3-7/16" |
| 7-1-1112 | 3-1/2" |
| 7-1-1114 | 3-9/16" |
| 7-1-1116 | 3-5/8" |
| 7-1-1118 | 3-11/16" |
| 7-1-1120 | 3-3/4" |
| 7-1-1122 | 3-13/16" |
| 7-1-1124 | 3-7/8" |
| 7-1-1126 | 3-15/16" |
| 7-1-1128 | 4" |

2" Depth

| Item ID: | Diameter |
|----------|----------|
| 7-1-214 | 7/16" |
| 7-1-216 | 1/2" |
| 7-1-218 | 9/16" |
| 7-1-220 | 5/8" |
| 7-1-222 | 11/16" |
| 7-1-224 | 3/4" |
| 7-1-226 | 13/16" |
| 7-1-228 | 7/8" |
| 7-1-230 | 15/16" |
| 7-1-232 | 1" |
| 7-1-234 | 1-1/16" |
| 7-1-236 | 1-1/8" |
| 7-1-238 | 1-3/16" |
| 7-1-240 | 1-1/4" |
| 7-1-242 | 1-5/16" |
| 7-1-244 | 1-3/8" |
| 7-1-246 | 1-7/16" |
| 7-1-248 | 1-1/2" |
| 7-1-250 | 1-9/16" |
| 7-1-252 | 1-5/8" |
| 7-1-254 | 1-11/16" |
| 7-1-256 | 1-3/4" |
| 7-1-258 | 1-13/16" |
| 7-1-260 | 1-7/8" |
| 7-1-262 | 1-15/16" |
| 7-1-264 | 2" |
| 7-1-266 | 2-1/16" |
| 7-1-268 | 2-1/8" |
| 7-1-270 | 2-3/16" |
| 7-1-272 | 2-1/4" |
| 7-1-274 | 2-5/16" |
| 7-1-276 | 2-3/8" |
| 7-1-278 | 2-7/16" |
| 7-1-280 | 2-1/2" |
| 7-1-282 | 2-9/16" |
| 7-1-284 | 2-5/8" |
| 7-1-286 | 2-11/16" |
| 7-1-288 | 2-3/4" |
| 7-1-290 | 2-13/16" |
| 7-1-292 | 2-7/8" |
| 7-1-294 | 2-15/16" |
| 7-1-296 | 3" |
| 7-1-298 | 3-1/16" |
| 7-1-2100 | 3-1/8" |
| 7-1-2102 | 3-3/16" |
| 7-1-2104 | 3-1/4" |
| 7-1-2106 | 3-5/16" |
| 7-1-2108 | 3-3/8" |
| 7-1-2110 | 3-7/16" |
| 7-1-2112 | 3-1/2" |
| 7-1-2114 | 3-9/16" |
| 7-1-2116 | 3-5/8" |
| 7-1-2118 | 3-11/16" |
| 7-1-2120 | 3-3/4" |
| 7-1-2122 | 3-13/16" |
| 7-1-2124 | 3-7/8" |
| 7-1-2126 | 3-15/16" |
| 7-1-2128 | 4" |

3" Depth*

| Item ID: | Diameter |
|----------|----------|
| N/A | |
| N/A | |
| N/A | |
| N/A | |
| N/A | |
| 7-1-324 | 3/4" |
| 7-1-326 | 13/16" |
| 7-1-328 | 7/8" |
| 7-1-330 | 15/16" |
| 7-1-332 | 1" |
| 7-1-334 | 1-1/16" |
| 7-1-336 | 1-1/8" |
| 7-1-338 | 1-3/16" |
| 7-1-340 | 1-1/4" |
| 7-1-342 | 1-5/16" |
| 7-1-344 | 1-3/8" |
| 7-1-346 | 1-7/16" |
| 7-1-348 | 1-1/2" |
| 7-1-350 | 1-9/16" |
| 7-1-352 | 1-5/8" |
| 7-1-354 | 1-11/16" |
| 7-1-356 | 1-3/4" |
| 7-1-358 | 1-13/16" |
| 7-1-360 | 1-7/8" |
| 7-1-362 | 1-15/16" |
| 7-1-364 | 2" |
| 7-1-366 | 2-1/16" |
| 7-1-368 | 2-1/8" |
| 7-1-370 | 2-3/16" |
| 7-1-372 | 2-1/4" |
| 7-1-374 | 2-5/16" |
| 7-1-376 | 2-3/8" |
| 7-1-378 | 2-7/16" |
| 7-1-380 | 2-1/2" |
| 7-1-382 | 2-9/16" |
| 7-1-384 | 2-5/8" |
| 7-1-386 | 2-11/16" |
| 7-1-388 | 2-3/4" |
| 7-1-390 | 2-13/16" |
| 7-1-392 | 2-7/8" |
| 7-1-394 | 2-15/16" |
| 7-1-396 | 3" |
| 7-1-398 | 3-1/16" |
| 7-1-3100 | 3-1/8" |
| 7-1-3102 | 3-3/16" |
| 7-1-3104 | 3-1/4" |
| 7-1-3106 | 3-5/16" |
| 7-1-3108 | 3-3/8" |
| 7-1-3110 | 3-7/16" |
| 7-1-3112 | 3-1/2" |
| 7-1-3114 | 3-9/16" |
| 7-1-3116 | 3-5/8" |
| 7-1-3118 | 3-11/16" |
| 7-1-3120 | 3-3/4" |
| 7-1-3122 | 3-13/16" |
| 7-1-3124 | 3-7/8" |
| 7-1-3126 | 3-15/16" |
| 7-1-3128 | 4" |

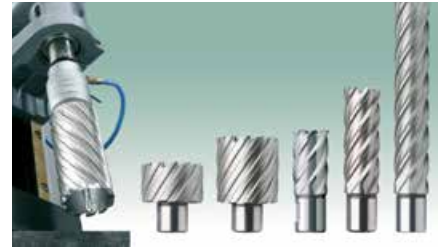

Shank size:

3/4" for cutters up to 3" dia.
1-1/4" for cutters 3-1/16 and larger.

Pilot pin not included with 7-series annular cutters

Cutter Kits

Each cobalt cutter kit comes with the following: 9/16", 11/16", 13/16", 15/16", 1-1/16", pilot pins & carrying case.

| Item ID: | Description |
|----------|---------------------|
| 7-1-002A | 2" depth Cutter Kit |

Pilot Pins for 7-Series

| Item ID: | Description |
|--------------------------|---------------------------------|
| For 3/4" Shanks | |
| 7-3-102 | 7/16" - 3" dia., 1" depth |
| 7-3-202 | 7/16" - 3" dia., 2" depth |
| 7-3-302 | 3/4" - 3" dia., 3" depth |
| For 1-1/4" Shanks | |
| 7-3-1002 | 3-1/16" - 5-1/8" dia., 1" depth |
| 7-3-2002 | 3-1/16" - 5-1/8" dia., 2" depth |
| 7-3-3002 | 3-1/16" - 5-1/8" dia., 3" depth |

Option for Cutters 3"

| | |
|---------|---|
| 7-3-402 | 2-piece pin for 3" cutters with 8mm pilot hole. |
|---------|---|

* Cutters with 3" depth have an 8mm dia. pilot hole.



Scan or visit
www.csunitec.com to
see all sizes available

For Larger Diameter up to 6" or larger, and longer lengths up to 10", please see our 9-series carbide annular cutters. Call today to speak to a CS Unitec specialist!

10-Series One-Touch TCT

Tungsten carbide-tipped with one-touch shank

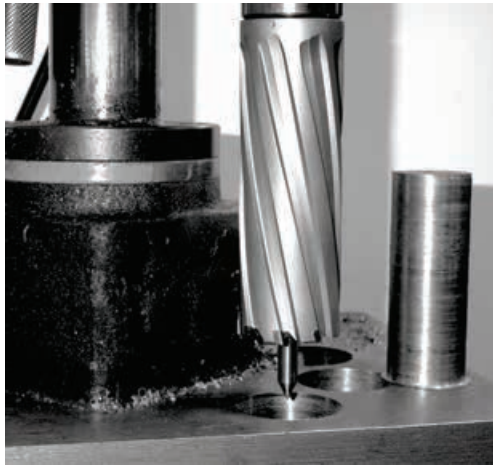

- No-tool cutter replacement
- When holding with a set screw, tighten to weldon flat rather than dimple area
- Leaves a burr-free finished hole
- 3/4" shank
- Compatible with Nitto Kohki and other auto-feed machines
- Armor plating also available upon request



One-Touch TCT cutters are available in the following sizes:

- 1-3/8" drill depth – \varnothing 1/2" to \varnothing 2"
- 2-3/8" drill depth – \varnothing 1/2" to \varnothing 2³/₄"
- 3-3/8" drill depth – \varnothing 1¹/₁₆" to \varnothing 1¹/₁₆"
- 4" drill depth – \varnothing 1¹/₁₆" to \varnothing 1¹/₁₆"

Metric, Stack and 32nd Size Cutters also Available.

Every annular cutter up to 4" DOC includes a pilot pin.*

- Metric cutters available on request

Pilot pin included with every 10-Series annular cutter



Pilot Pins for 10-Series

| Item ID: | Description |
|------------------------|-------------------------------------|
| For 3/4" Shanks | |
| 9-3-102 C | 9/16" - 2" dia., 1-3/8" depth |
| 9-3-202 C | 1/2" - 2-3/4" dia., 2-3/8" depth |
| 9-3-302 C | 11/16" - 1-1/16" dia., 3-3/8" depth |
| 9-3-402 C | 11/16" - 1-1/16" dia., 4" depth |

1-3/8" Depth

| Item ID: | Diameter |
|------------|----------|
| 10-1-116 C | 1/2" |
| 10-1-118 C | 9/16" |
| 10-1-120 C | 5/8" |
| 10-1-122 C | 11/16" |
| 10-1-124 C | 3/4" |
| 10-1-126 C | 13/16" |
| 10-1-128 C | 7/8" |
| 10-1-130 C | 15/16" |
| 10-1-132 C | 1" |
| 10-1-134 C | 1-1/16" |
| 10-1-136 C | 1-1/8" |
| 10-1-138 C | 1-3/16" |
| 10-1-140 C | 1-1/4" |
| 10-1-142 C | 1-5/16" |
| 10-1-144 C | 1-3/8" |
| 10-1-146 C | 1-7/16" |
| 10-1-148 C | 1-1/2" |
| 10-1-150 C | 1-9/16" |
| 10-1-152 C | 1-5/8" |
| 10-1-154 C | 1-11/16" |
| 10-1-156 C | 1-3/4" |
| 10-1-158 C | 1-13/16" |
| 10-1-160 C | 1-7/8" |
| 10-1-162 C | 1-15/16" |
| 10-1-164 C | 2" |

2-3/8" Depth

| Item ID: | Diameter | Item ID: | Diameter |
|------------|----------|------------|----------|
| 10-1-216 C | 1/2" | 10-1-266 C | 2-1/16" |
| 10-1-218 C | 9/16" | 10-1-268 C | 2-1/8" |
| 10-1-220 C | 5/8" | 10-1-270 C | 2-3/16" |
| 10-1-222 C | 11/16" | 10-1-272 C | 2-1/4" |
| 10-1-224 C | 3/4" | 10-1-274 C | 2-5/16" |
| 10-1-226 C | 13/16" | 10-1-276 C | 2-3/8" |
| 10-1-228 C | 7/8" | 10-1-278 C | 2-7/16" |
| 10-1-230 C | 15/16" | 10-1-280 C | 2-1/2" |
| 10-1-232 C | 1" | 10-1-282 C | 2-5/8" |
| 10-1-234 C | 1-1/16" | 10-1-288 C | 2-3/4" |
| 10-1-236 C | 1-1/8" | | |
| 10-1-238 C | 1-3/16" | | |
| 10-1-240 C | 1-1/4" | | |
| 10-1-242 C | 1-5/16" | | |
| 10-1-244 C | 1-3/8" | | |
| 10-1-246 C | 1-7/16" | | |
| 10-1-248 C | 1-1/2" | | |
| 10-1-250 C | 1-9/16" | | |
| 10-1-252 C | 1-5/8" | | |
| 10-1-254 C | 1-11/16" | | |
| 10-1-256 C | 1-3/4" | | |
| 10-1-258 C | 1-13/16" | | |
| 10-1-260 C | 1-7/8" | | |
| 10-1-262 C | 1-15/16" | | |
| 10-1-264 C | 2" | | |

3-3/8" Depth

| Item ID: | Diameter |
|------------|----------|
| 10-1-322 C | 11/16" |
| 10-1-326 C | 13/16" |
| 10-1-330 C | 15/16" |
| 10-1-334 C | 1-1/16" |

4" Depth

| Item ID: | Diameter |
|------------|----------|
| 10-1-422 C | 11/16" |
| 10-1-426 C | 13/16" |
| 10-1-430 C | 15/16" |
| 10-1-434 C | 1-1/16" |



Scan or visit
www.csunitec.com to
see all sizes available

➤ Accessories: pages 70-75

Rail Cutters

Cut holes up to 1-11/16" dia. in track rail

- Round, clean, burr-free hole – better than spade drills
- 3/4" shank
- More cutting teeth to distribute the load evenly – increase tool life and achieve faster feed rates
- Pilot pin included with each 4-Series cutter
- Armor plating available upon request



4-Series TCT Rail Cutters

- Carbide-tipped rail bits for long life and quick, efficient cutting through rust and corrosion



1-3/8" Depth

| Item ID: | Diameter | Item ID: | Diameter |
|-----------|----------|-----------|----------|
| 4-1-124 C | 3/4" | 4-1-140 C | 1-1/4" |
| 4-1-128 C | 7/8" | 4-1-142 C | 1-5/16" |
| 4-1-130 C | 15/16" | 4-1-144 C | 1-3/8" |
| 4-1-132 C | 1" | 4-1-146 C | 1-7/16" |
| 4-1-134 C | 1-1/16" | 4-1-148 C | 1-1/2" |
| 4-1-136 C | 1-1/8" | 4-1-152 C | 1-5/8" |
| 4-1-138 C | 1-3/16" | 4-1-154 C | 1-11/16" |



Scan or visit
www.csunitec.com to
see all sizes available

Pilot Pin for 4-47-Series

| Item ID: | Description |
|----------|--|
| 4-3-102 | For 3/4" Shanks 3/4" - 1-11/16" dia., 1-3/8" depth |

47-Series Lightning Rail Cutters

- Cobalt rail bits for increased wear resistance
- Thick cutter wall for extra durability and extended tool life
- Turn-style mounting allows quick and easy installation without tools.



Scan or visit
www.csunitec.com to
see all sizes available

1-1/4" Depth

| Item ID: | Diameter | Item ID: | Diameter |
|------------|----------|------------|----------|
| 47-1-124 C | 3/4" | 47-1-140 C | 1-1/4" |
| 47-1-128 C | 7/8" | 47-1-142 C | 1-5/16" |
| 47-1-130 C | 15/16" | 47-1-144 C | 1-3/8" |
| 47-1-132 C | 1" | 47-1-146 C | 1-7/16" |
| 47-1-134 C | 1-1/16" | 47-1-148 C | 1-1/2" |
| 47-1-136 C | 1-1/8" | 47-1-152 C | 1-5/8" |
| 47-1-138 C | 1-3/16" | 47-1-154 C | 1-11/16" |

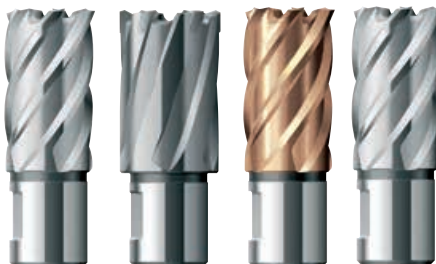

See pages 60-68 for our
Annular Cutters - HSS,
Carbide-tipped, Armor Plated,
& Cobalt. Available up to 6"
Dia. and 10" Depth.



Scan or visit
www.csunitec.com to
see all sizes available

Carbide-Tipped Hole Saws



Cut holes in steel plate



Model EHB 16/2.4
S R/L C: 2-speed,
variable-speed drill
with safety clutch

- Tungsten carbide-tipped cutting edges last longer and can be run at higher feeds and speeds to create holes of exceptional quality and accuracy
- One-piece construction; diameters from 9/16" to 4 1/2"

Designed for use with hand-held drills – recommended drills include our EHB 16 series or other hand-held drills with slip clutch



1-Series Carbide-Tipped Hole Cutters

1" effective length
Center twist pilot drill
Safety Collar Stop

3/8" shank on cutters up to 3-1/4" dia.
1/2" shank on cutters 3-5/16" dia. and larger

2-Series Carbide-Tipped Hole Cutters Extra Heavy Duty

5/8" effective length
Spring-loaded Pilot Pin

Cutters feature milled, 3-flat shank designed to fit 1/2" chucks.



| Item ID: | Diameter |
|----------|----------|
| 1-1-118* | 9/16" |
| 1-1-120* | 5/8" |
| 1-1-122 | 11/16" |
| 1-1-124 | 3/4" |
| 1-1-126 | 13/16" |
| 1-1-128 | 7/8" |
| 1-1-130 | 15/16" |
| 1-1-132 | 1" |
| 1-1-134 | 1-1/16" |
| 1-1-136 | 1-1/8" |
| 1-1-138 | 1-3/16" |
| 1-1-140 | 1-1/4" |
| 1-1-142 | 1-5/16" |
| 1-1-144 | 1-3/8" |
| 1-1-146 | 1-7/16" |
| 1-1-148 | 1-1/2" |
| 1-1-150 | 1-9/16" |
| 1-1-152 | 1-5/8" |
| 1-1-154 | 1-11/16" |
| 1-1-156 | 1-3/4" |
| 1-1-158 | 1-13/16" |
| 1-1-160 | 1-7/8" |
| 1-1-162 | 1-15/16" |
| 1-1-164 | 2" |

| Item ID: | Diameter |
|----------|----------|
| 1-1-166 | 2-1/16" |
| 1-1-168 | 2-1/8" |
| 1-1-170 | 2-3/16" |
| 1-1-172 | 2-1/4" |
| 1-1-174 | 2-5/16" |
| 1-1-176 | 2-3/8" |
| 1-1-178 | 2-7/16" |
| 1-1-180 | 2-1/2" |
| 1-1-182 | 2-9/16" |
| 1-1-184 | 2-5/8" |
| 1-1-186 | 2-11/16" |
| 1-1-188 | 2-3/4" |
| 1-1-190 | 2-13/16" |
| 1-1-192 | 2-7/8" |
| 1-1-194 | 2-15/16" |
| 1-1-196 | 3" |
| 1-1-198 | 3-1/16" |
| 1-1-1100 | 3-1/8" |
| 1-1-1102 | 3-3/16" |
| 1-1-1104 | 3-1/4" |
| 1-1-1106 | 3-5/16" |
| 1-1-1108 | 3-3/8" |
| 1-1-1110 | 3-7/16" |
| 1-1-1112 | 3-1/2" |

| Item ID: | Diameter |
|----------|----------|
| 1-1-1114 | 3-9/16" |
| 1-1-1116 | 3-5/8" |
| 1-1-1118 | 3-11/16" |
| 1-1-1120 | 3-3/4" |
| 1-1-1122 | 3-13/16" |
| 1-1-1124 | 3-7/8" |
| 1-1-1126 | 3-15/16" |
| 1-1-1128 | 4" |
| 1-1-1136 | 4-1/4" |
| 1-1-1144 | 4-1/2" |

| Item ID: | Diameter |
|----------|----------|
| 2-1-118 | 9/16" |
| 2-1-120 | 5/8" |
| 2-1-122 | 11/16" |
| 2-1-124 | 3/4" |
| 2-1-126 | 13/16" |
| 2-1-128 | 7/8" |
| 2-1-130 | 15/16" |
| 2-1-132 | 1" |
| 2-1-134 | 1-1/16" |
| 2-1-136 | 1-1/8" |
| 2-1-138 | 1-3/16" |
| 2-1-140 | 1-1/4" |
| 2-1-142 | 1-5/16" |
| 2-1-144 | 1-3/8" |

1-Series Accessories

| Item ID: | Description |
|------------|--------------------|
| 1-1-drill | Center Pilot Drill |
| 1-1-spring | Spring |
| 1-1-screw | Screw |

2-Series Accessories

| Item ID: | Description |
|-----------|-------------------|
| 2-1-PILOT | Pilot/Ejector Pin |
| 2-1-SCREW | Screw |



Scan or visit
www.csunitec.com to
see all sizes available

* These cutters do not include springs.

➤ Annular Cutters: pages 60-68 ➤ Accessories: pages 70-75

Accessories

Coolants and Cutting Pastes

Coolant extends the life of cutting tools – Ideal for cutting steel, stainless steel and hard metals

ProLube™

Your cutting tools will work cooler, longer and more efficiently with ProLube™ Lubricants from CS Unitec.

- Prolong tool life by reducing friction and wear
- Unique composition provides excellent adhesion to cutting tools for maximum lubrication
- Corrosion inhibitor
- Non-toxic



ProLube™

Paste (12 oz. tub) – Item ID: **CS 7030-712**

Liquid (1 gallon (water soluble 16:1))

– Item ID: **CS 7010-504**



- High-performance
- Liquid coolant is concentrated for dilution with water
- Eco-friendly

Paste (tube) – Item ID: **ZHS 570**

Paste (12-pack tubes) – Item ID: **ZHS 572**

Paste (2.2 lb. tub) – Item ID: **ZHS 550**

Liquid* (1 quart) – Item ID: **ZHB 001**

* Water soluble 10:1

Upgrade your drill's cooling system: see page 71 for arbors with automatic cooling.

Cutting Oil

- High-performance, biodegradable, non-hazardous oils and pastes
- Oils for heavy removal of metal, including stainless steel
- Chlorine-free (MSDS on bottle/tub)
- Not necessary to dilute with water

Cutting Oil:

Item ID: **ZHS 006** (quart)

Item ID: **ZHS 005** (gallon)



Pressurized Coolant Bottle

Use with any automatic internal lubrication system.

Item ID: **9 4002 0020 N**

Pilot Pins for Cutters

- Milled channel efficiently supplies internal lubrication to cutting teeth
- Available for cutter diameters ranging from 7/16" to 6" and up to 8" depth of cut
- See price list for Item ID:s



*Shown at right:
2-piece pin for
3" and 4" depth
cutters with
8mm pilot hole
(Item ID: 7-3-402).*



Accessories



Arbors for Annular Cutters

- Use on any magnetic drill stand, drill press or shop equipment with a Morse Taper intake of No. 2, 3 or 4
- Available for Annular Cutter shank sizes of 3/4" or 1 1/4" Weldon
- Available for automatic internal cooling or manual cooling



Manual Cooling

- ZIA 219M** – Morse Taper No. 2
3/4" arbor bore
- ZIA 319M** – Morse Taper No. 3
3/4" arbor bore
- ZIA 30/75** – Morse Taper No. 3
3/4" arbor bore, 3" depth
- ZIA 419M** – Morse Taper No. 4
3/4" arbor bore
- ZIA 432M** – Morse Taper No. 4
1-1/4" weldon shank



Automatic Cooling

- ZIA 219KN** – Morse Taper No. 2
3/4" arbor bore
- ZIA 319KN** – Morse Taper No. 3
3/4" arbor bore
- ZIA 30/32** – Morse Taper No. 3
1 1/4" arbor bore
- ZIA 432 KN** – Morse Taper No. 4
1 1/4" arbor bore

Quick-Lock Arbor with Automatic Internal Cooling

- Keyless for fast, no-tools changeover for 3/4" dia. shank annular cutters
- Automatic internal cooling
- Turn, click... go!

ZSS 200 – Morse Taper No. 2
for 3/4" dia. shank
annular cutters

ZSS 300 – Morse Taper No. 3
for 3/4" dia. shank
annular cutters



*turn,
click...*



*Keyless,
quick-change
system for annular
cutters saves time
and money.*

Just twist and lock!



Drill Chucks for Straight-Shank Twist Drills

- Two capacities: 1/2" and 3/4"; four chucks and adapters to fit all magnetic drills

- A) **IBC 17** – 1/2" chuck for CSU 32 & Magnetic Drills with 1/2"x20 thread connections
- B) **IBC 18** – 1/2" chuck with 3/4" shank for MABasic 200, MABasic 400 and AIRBOR™ (fits all drills with 3/4" arbor bore)
- C) **IBC 21** – 3/4" chuck with MT3 shank for MAB 525, MAB 825, MAB 845 and RT5
- D) **IBC 22** – 3/4" chuck with MT2 shank for MABasic 450, MAB 455, MAB 485 and AutoMAB 450



Accessories

Weldon Shank Twist Drill Bits Optimized for Increased Cutting Life in Magnetic Drills

- Made of M2 High Speed Steel (HSS) for increased durability
- Industry standard 3/4" weldon shank (19.05 mm) for fast, dependable securing to magnetic drills
- Increase versatility with easy, small hole drilling for magnetic drills
- 2" Depth of cut

- 8-1-108S – 1/4" Dia.
- 8-1-110S – 5/16" Dia.
- 8-1-112S – 3/8" Dia.
- 8-1-114S – 7/16" Dia.

**Save Time, Easy Changeover,
No Chuck Adapter Needed!**

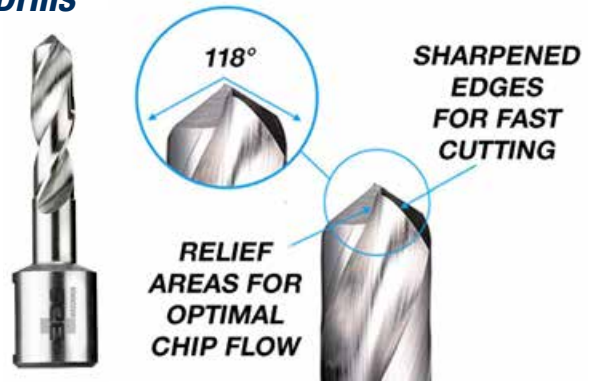

Extensions for Annular Cutters Extra-long holders extend stroke of drills



- Extend cutter reach up to 18"
- Available for magnetic drills with 3/4" arbor bore or MT3
- Also available with 3 flats for straight shank drill chucks and R8 shanks for drill presses
- Drill difficult-to-reach areas
- Extend cutter reach over the side or through an existing hole*

- 7-9-902 – 2" extension
- 7-9-903 – 3" extension
- 7-9-904 – 4" extension
- 7-9-906 – 6" extension
- 7-9-912 – 12" extension
- 7-9-918 – 18" extension

- 7-9-1146 – 6" extension,
1-1/4" male x 1-1/4" female shank

* Hole diameter must be larger than 1 5/16" to accommodate width of extension



We also offer extensions with the following connections:

3 Flats for Geared Chucks x 3/4" arbor



- 7-9-100 – 2-1/8" length, 1/2" shank
- 7-9-200 – 2" length, 3/4" shank

R8



- 7-9-500 – R8, 1-3/4" length; 3/4" arbor bore
- 7-9-506 – R8, 6" length; 3/4" arbor bore
- 7-9-700 – R8, 2-3/4" length; 1-1/4" arbor bore

2-in-1 Drill/Taps Drill and tap with one tool

National Coarse Threads (UNC) – sizes available:

- CS500 – 1/2" x 13 UNC
- CS625 – 5/8" x 11 UNC
- CS750 – 3/4" x 10 UNC
- CS875 – 7/8" x 9 UNC
- CS1000 – 1" x 8 UNC
- CSDT-UNCKIT N – 1/2", 5/8", 3/4" & 1" drill/taps



82° and 90° Countersinks

- Manufactured of HSS with 5% cobalt
- 3/4" Weldon shank

Countersink hole sizes:

- CTS 30 from 5/8" to 2" / 82°
- CTS 50 from 5/8" to 2 1/8" / 90°



Detachable Chip Guard

Protects against flying chips when drilling

- ZSS 050 – MAB 485 and MAB 525
- ZSS 500 – MAB 825 and MAB 845

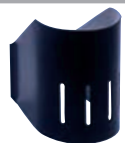

Accessories

Quick-Change Tapping Chucks

Item ID: **GSW.830C** tapping chuck includes two variable clamp collets to tap $\frac{3}{8}$ " to $1 \frac{1}{8}$ ". It is the least expensive system if you will tap more than 4 sizes. **GSW.830C** has an MT3 connection.



For use with all MT3 drills.

Variable clamp collets for use in tap chuck No. **GSW.830C**:

Item ID: **GST-160** for shanks $\frac{3}{8}$ " - $\frac{5}{8}$ ".

Item ID: **GST-230** for shanks $\frac{5}{8}$ " - $\frac{7}{8}$ ".



GSW 444
Quick-Change
Chuck

Item ID: **GSW 444** quick-change tapping chuck with MT4 connection (for MAB 1300). Collets not included.



| Order Number | Tap Collet | Shank Diameter | Square Drive |
|----------------|------------|----------------|--------------|
| GSS.420 | 20mm | 16mm | 12mm |
| GSS.422 | 22mm | 18mm | 14.5mm |
| GSS.427 | 27mm | 20mm | 16mm |
| GSS.430 | 30mm | 22mm | 18mm |
| GSS.433 | 33mm | 32mm | 20mm |
| GSS.436 | 36mm | 28mm | 22mm |
| GSS.442 | 42mm | 32mm | 24mm |



GSS-4xx
Collet

MobilCLAMP

A true advance in magnetic drilling technology: MobilCLAMP converts a magnetic drilling machine into a portable drill press.

The magnetic drill can be mounted onto the MobilCLAMP with only the power of the machine's magnet - no screws, clamps or needed. Increasing the versatility of magnetic drills.



Drill not included.



MobilCLAMP

| | |
|----------------|------------|
| Item ID: | ZMC 200 |
| Jaw Width | 4" (100mm) |
| Clamping Range | 4" (100mm) |

ZMC 200 N includes ZMC 200 base, ZST 300 vise, (2 qty.) ZTN 100 screw and (2 qty.) ZSN 100 hexagon nut with collar

Drilling stand and vise for hand drills



Vise

Item ID: **ZST 300**
jaw width: 4" (100mm)
clamping range: 4" (100mm)

Accessories

Screws for T-Slots - Item ID: **ZTN 100**

Hexagon Nut with Collar - Item ID: **ZSM 100**

Drilling Pillar

Item ID: **ZBS 100**

- Industrial drilling pillar for commercial hand drills with 43mm chuck journal diameter.
- 8" Stroke
- Fits ZST 300 vise accessory



Drill & Vise
not included.

Magnetic Drilling Pillar

Item ID: **MBS 300 - 220V**
Item ID: **MBS 300.2 - 110V**

For hand drills with a 1-11/16" collar diameter and 7" stroke.



Drill not included.

Vacuum Plates

For applications where drill alone will not adhere to surface

Vacuum Plate for Channeled Plates

Item ID: **ZAV 301** (vacuum plate only)

Item ID: **ZAV 310** (vacuum plate and vacuum pump, 110V)

Item ID: **253.511** (vacuum pump, 110V)

Ideal for channeled plates. High-performance vacuum pump with circular oil lubrication. Clamping plate diameter: 11.8"

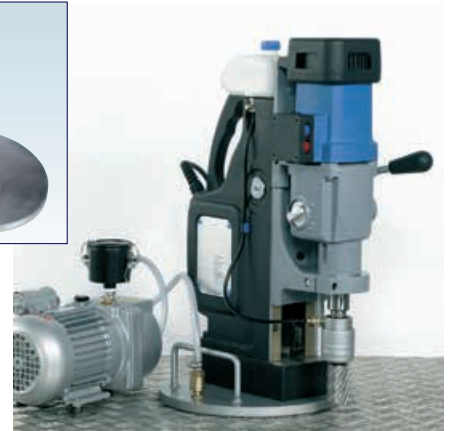
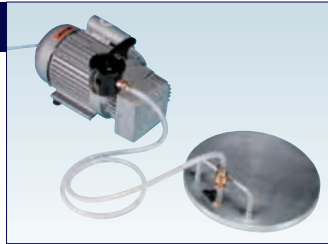

Vacuum Plate for Smooth Surfaces

Item ID: **ZAV 401** (vacuum plate only)

Item ID: **ZAV 410** (vacuum plate and vacuum pump, 110V)

Item ID: **253.511** (vacuum pump, 110V)

Ideal for smooth surfaces. High-performance vacuum pump with circular oil lubrication. Clamping plates with two suction surfaces and cut-through drilling area.



Metal Chip Cleanup Tools

- Easily clean up sharp-edged drill chips, screws and other metal parts
- Ideal for hard-to-reach spaces

Power Worker

Item ID: **POW 200**

Two-in-one tool for removing chips

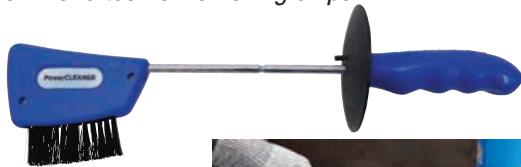

- Hook pulls away metal swarf from drill
- Brush cleans fine chips



Power Worker

Item ID: **POW 100**

Simple cleanup of metal chips

- Items are safely ejected off of Power Worker without hand contact
- Rare earth magnet cleans metal parts and shavings



Pipe Drilling Solutions

Ensures safe, secure drilling of pipes and tubular material

- Ideal for drilling on pipe, flat or curved surfaces
- Easily attaches to pipe over 3" OD
- Strong magnets adhere to material as thin as 9/64" (3mm)
- Drilling up to 3-15/16" Dia. holes, tapping up to 1-3/16"
- Increased safety with patented permanent magnet system

See pages 36-38 for
PipeMAB specifications

PipeMAB 200



PipeMAB 525



PipeMAB 825



Pipe Saddle Clamps



Scan or visit
www.csunitec.com
to learn more



ZRO 250 Pipe Saddle Clamp

Pipe diameters 3¹/₄" - 10"
Chain length: 35¹/₂"
For pipe larger than 10", use 2 qty. ZRO 001 extension chains.
For models: MABasic 200, MABasic 400, MABasic 450, MAB 455, MAB 465, MAB 485 & CSU 32



ZRO 500 Pipe Saddle Clamp

Pipe diameters 6" - 20" (extension chain available)
Chain length: 65"
For pipe larger than 20", use 2 qty. ZRO 001 extension chains.
For models: MABasic 850, MAB 525, MAB 825, MAB 845, AB-4300-2 and HB 4400



2 1330 8500 Pipe Saddle Clamp

Pipe diameters 6" - 19.5" (extension chain available)
Chain length: 65"
For pipe larger than 19.5", order 5 1201 9030 extension chain for pipe up to 31.5"OD, order 5 1201 9020 extension chain for pipe up to 43.25"OD
For model: 2 1345 0020

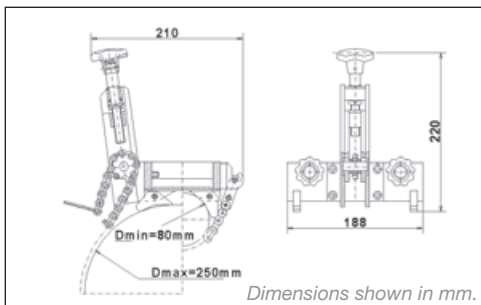

Item ID: **ZRO 001**
extension chain for
ZRO 250 and ZRO 500
pipe saddle clamps.
35" length.

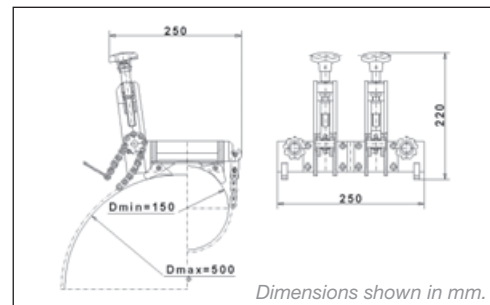

Electric Drills and Drive Units

High-torque, multi-gearred and variable-speed motors



Model
EHB 16/2.4 S R/L C



Model
EHB 20/2.4



Model
EHB 32/4.2



Model
EHB 16/2.4 S/RL



Model
EAU 34/4 CB



Model
EAU 36/4 R R/L CB

Heavy-Duty Drills for Industry and Construction:

- High-torque output
- Variable-speed, two- and four-gearred drills for optimum speed selection
- Reversible motors and electronic torque control on selected models
- Ideal for special applications including valve turning, tube rolling and other jobs
- Safety slip clutch on 1¹/₄" capacities to protect operator and tool
- Drilling capacities up to 1¹/₄" in steel
- Special OEM motors available on request
- One-year warranty



Scan to
Learn More



| Model No. | Motor Power (Amps) | Voltage | Load Speed (RPM) | Drilling Capacity in Steel | Max. Torque Output (ft./lbs.) | Reversible | Chuck/Arbor | Weight (lbs.) |
|--|--------------------|---------|--|---------------------------------|-------------------------------|------------|--------------|---------------|
| EHB 16/2.4 S/RL | 10 | 110V | 0-430/0-760 | 5/8" | 19 | YES | 5/8" Geared | 7 |
| EHB 16/2.4 S R/L C with slip clutch | 10 | 110V | 0-430/0-760 | 5/8" | 19 | YES | 5/8" Geared | 7 |
| EAW 16/2 R/L | 9 | 110V | 510/950 | N/A | 8 | YES | 5/8" X 16 UN | 7 |
| EHB 20/2.4 | 10.5 | 110V | 250/450 | 3/4" | 32 | NO | MT2 | 9.2 |
| EHB 32/4.2 | 15.5 | 110V | 110/175/245/385 | 1 ¹ / ₄ " | 112 | NO | MT3 | 15.2 |
| EAU 34/4 CB** | 20 | 110V | 80/130/360/570 | - | 203 | YES | MT3 | 19.5 |
| EAU 36/4 R R/L CB** with 4-speed gearbox and variable speed | 22 | 110V | 50-120 80-190 110-270 180-420 | - | 187 | YES | MT3 | 20 |

* All units available in 220 Volt / 50Hz

** EAU 34/4 CB and EAU 36/4 R R/L CB include control box Special Motors available upon request.

Electric Drills and Drive Units

Slow Speed: two-gear, variable-speed reversible motors



Model ETE 32/2.3 R/RL
(shown with optional
Square Drive adapter)

- High-torque, two-gear and variable-speed reversible motors
- Ideal for drilling, reaming and tapping steel
- Driving applications include mills, spindles, bar boring, pipe beveling and valve turning
- Perfect for tube rolling and expanding for fire tube and water tube boilers
- Mechanical safety clutch prevents operator injury or damage to the tool
- Morse Taper #3 arbor
- One-year warranty



Scan to
Learn More



Model EHB 32/2.2 R/RL
Model ETE 32/2.3 R/RL



3/4" Geared Chuck
with MT3 shank
(IBC 21)



1/2" and 3/4"
Square Drive
accessories
allow motor
compatibility
for various drive
applications.*



Up to 1 1/4" twist
drill capacity

| Model No. | Motor Power (Amps) | Voltage** | Load Speed (RPM) | Drilling Capacity in Steel | Tube Rolling (max.) | Reversible | Torque Output (ft./lbs.) | Torque Control | Arbor | Weight (lbs.) |
|------------------------|--------------------|-----------|--------------------|----------------------------|---------------------|------------|--------------------------|----------------|-------|---------------|
| EHB 32/2.2 R/RL | 15 | 110V | 60-140/ 200-470 | 1 1/4" | 2" | YES | 95 max. | YES | MT3 | 14 |
| ETE 32/2.3 R/RL | 15 | 110V | 30-75/ 90-230 | N/A | 3" *** | YES | 174 max. | No | MT3 | 15 |

** All units available in 220 Volt / 50Hz

*** With Expander (Up to 2 1/2" with Bead Roller)

* 1/2" Square Drive with MT3 – Item ID: 830-1230-050

3/4" Square Drive with MT3 – Item ID: 830-1230-075

Pneumatic Drills and Drive Units

High-torque reversible drilling and tapping machines

ATEX

Scan to
Learn More



- High-torque reversible drilling, tapping and threading machines
- Ideal for drilling, reaming, tube rolling, tube expanding and tapping
- Special applications include mills, spindles, slides, controllers, pipe tapping, valve turning and more
- Drill chucks and Morse Taper arbors
- Hammer drills for drilling concrete with up to 2200 blows per minute
- Special OEM air motors available on request
- 6-month warranty

Morse Taper Drills w/ Feed Spindle



Model
2 2089 0030
with reverse and
safety twist throttle

D-handle Drills



Model
2 1310 0010

Pneumatic Hammer Drills



Model 2 1266 0010

Pneumatic Pistol Drills



Model
2 1261 0010



See page 80
for Rotary
Hammer Drills

| Model No. | Motor Power (HP) | Load Speed (RPM) | Reversible | Chuck/ Arbor | Drilling Capacity in Steel | Tube Rolling Capacity | Torque Output (ft./lbs.) | CFM at 90 PSI | Length | Feed Length | Weight (lbs.) |
|---|------------------|------------------|------------|--------------|---------------------------------|---------------------------------|--------------------------|---------------|----------------------------------|---------------------------------|---------------|
| Pistol Drills | | | | | | | | | | | |
| 2 1261 0010 | 0.7 | 850 | NO | 1/2" Chuck | 1/2" | N/A | 7 max. | 21 | 9 ³ / ₄ " | N/A | 4.6 |
| Hammer Drills (for concrete and underwater applications) | | | | | | | | | | | |
| 2 1266 0010 | 0.75 | 950 | NO | 1/2" Chuck | 1/2" | N/A | 7 max. | 21 | 12" | N/A | 6.7 |
| D-Handle Drills | | | | | | | | | | | |
| 2 1310 0010 | 0.8 | 650 | NO | 1/2" Chuck | 1/2" | N/A | 8 max. | 24 | 12 ¹ / ₂ " | N/A | 12 |
| 2 1311 0010 | 0.8 | 650 | NO | MT1 | 5/8" | N/A | 8 max. | 24 | 11" | N/A | 12 |
| Morse Taper Drills w/ Feed Spindle | | | | | | | | | | | |
| 2 2089* | 1.7 | 250 | YES | MT3 | 1 ¹ / ₄ " | 1" | 36 max. | 24 | 26 ¹ / ₂ " | 1 ⁵ / ₈ " | 28 |
| 2 2506* | 2.5 | 220 | YES | MT3 | 1 ¹ / ₄ " | 2" | 63 max. | 70 | 26 ¹ / ₂ " | 2 ¹ / ₂ " | 32 |
| 2 2502* | 2.5 | 80 | YES | MT4 | 2" | 2 ¹ / ₂ " | 173 max. | 70 | 26 ¹ / ₂ " | 2 ¹ / ₂ " | 37 |

* The last four digits of the Model No. identify the type of throttle.

Please specify the four digits when ordering: 0010 for Lever Throttle or 0030 for Safety Twist Throttle.

Corner Drills and Drives



Pneumatic, electric and hydraulic: high-torque drilling, reaming and driving units



Model 2 1801 0030

Corner Drills and Bridge Reamers

- Small side-to-side distance for tight spaces
- Self-closing roll throttle
- Built-in oiler for motor
- Ideal for bridge reaming and drilling applications
- 6-month warranty
- Visit www.csunitec.com for dimensions

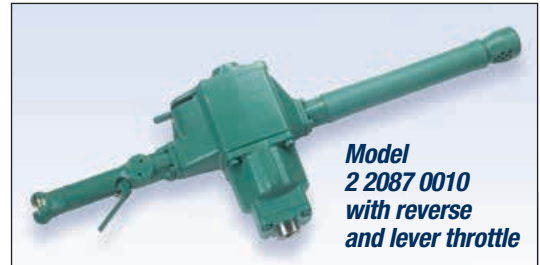
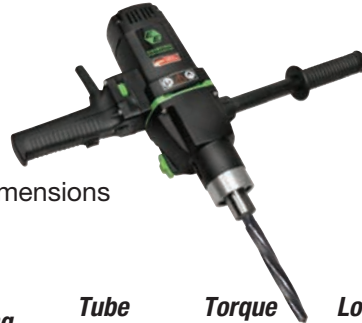

Model 2 2087 0010 with reverse and lever throttle

- Ideal for heavy-duty reaming, tube expanding and tapping
- Perfect for special driving applications, including pipe tapping and valve turning

† Square Drive Accessories

2 2089 7020 – 7/8" Male Sq. Drive to 3/4" Male Sq. Drive
 6 1016 7940 – 7/8" Male Sq. Drive to 1" Male Sq. Drive with retaining pin

| Pneumatic Corner Drill Model No. | Morse Taper | Drilling (in steel) | Reaming (in steel) | Tube Rolling Capacity | Torque Output (ft./lbs.) | Load Speed (RPM) | Motor Power (HP) | CFM at 90 PSI | Length | Weight (lbs.) |
|----------------------------------|-------------|---------------------|--------------------|-----------------------|--------------------------|------------------|------------------|---------------|--------|---------------|
| Nonreversible | | | | | | | | | | |
| 2 1602 0030 | #1 | 5/8" | 1/2" | N/A | 7 | 500 | 0.7 | 21 | 12.5" | 7 |
| 2 1701 0030 | #2 | 7/8" | 5/8" | N/A | 35 | 270 | 1.8 | 49 | 20.9" | 19 |
| 2 1801 0030 | #3 | 1 1/4" | 1" | N/A | 53 | 260 | 2.6 | 63 | 22.5" | 25 |
| Reversible | | | | | | | | | | |
| 2 2104 0030 | #4 | 2 1/8" | 2" | 2" | 86 | 2 1/2" | 3.0 | 71 | 23.8" | 37 |

Model No. 2 1602 0030 has a 3/8" NPT air inlet. 1/2" (13mm) hose is recommended. All other models have 3/4" NPT air inlet. A 1/2" (13mm) hose is recommended for model 2 1701 0030. A 5/8" (15mm) hose is recommended for models 2 1801 0030 and 2 2104 0030.

| Hydraulic Corner Drill Model No. | Morse Taper | Drilling (in steel) | Reaming (in steel) | Tube Rolling Capacity | Torque Output (ft./lbs.) | Load Speed (RPM) | Motor Power (HP) | Oil Flow/PSI | Length | Weight (lbs.) |
|----------------------------------|-------------|---------------------|--------------------|-----------------------|--------------------------|------------------|------------------|--------------|--------|---------------|
| 2 1806 0010 | #3 | 1 1/4" | 1" | N/A | 60 | 220 | 3.8 | 4 GPM @ 2000 | 21" | 25 |

| Electric Drill Model No. | Motor Power (Amps) | Voltage | Load Speed (RPM) | Drilling (in steel) | Tube Rolling Capacity | Reversible | Torque Output (ft./lbs.) | Torque Control | Arbor | Weight (lbs.) |
|--------------------------|--------------------|---------|------------------|---------------------|-----------------------|------------|--------------------------|----------------|-------|---------------|
| EHB 32/2.2 R/RL | 16.3 | 110 | 60-140, 200-470 | 1 1/4" | 2" | Yes | 92 max. | Yes | MT3 | 14 |

| Pneumatic Drive Unit Model No. | Square Drive ID | Torque Output (ft./lbs.) | Load Speed (RPM) | Reversible | Tube Rolling Capacity | Tapping Capacity | Motor Power (HP) | CFM at 90 PSI | Height x Length | Weight (lbs.) |
|--------------------------------|-----------------|--------------------------|------------------|------------|-----------------------|------------------|------------------|---------------|-----------------|---------------|
| 2 2081* | 13/16" | 413 | 20 | YES | 3" | 1 1/2" | 1.35 | 53 | 10.9" x 26.5" | 29 |
| 2 2087*† | 7/8" | 413 | 20 | YES | 3" | 1 1/2" | 1.35 | 53 | 10.9" x 26.5" | 29 |
| 2 2088*† | 7/8" | 138 | 60 | YES | 2" | 3/4" | 1.35 | 53 | 10.9" x 26.5" | 29 |

* The last four digits of the Model No. identify the type of throttle. † Square drive accessories available (see above). Please specify the four digits when ordering: 0010 for Lever Throttle or 0030 for Safety Twist Throttle.

CORNER DRILLS AND DRIVES

SDS Rotary Hammer Drills

ATEX

Pneumatic and hydraulic: powerful percussion drilling for concrete and masonry

- SDS Plus or SDS Max models
- Safety clutch protects against overloading and jamming
- Hammer drill holes in concrete, brick and masonry
- Rotary drilling mode for straight drilling of steel and wood
- Open center hydraulic standard, closed center optional

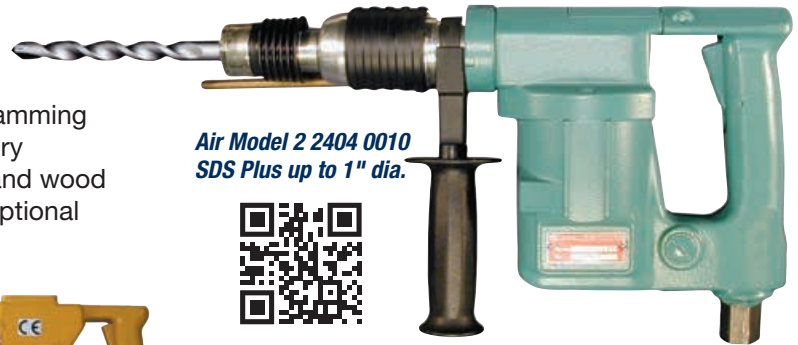

Air Model 2 2404 0010
SDS Plus up to 1" dia.



SDS Max – Modes of Operation

2" bit capacity for drilling concrete and masonry

Hammer with Rotation
Ideal for concrete drilling

Rotation Only For drilling steel and wood (not reversible)



Air Model 2 2417 0010
SDS Max

SDS Plus – Hammer and Drill

1" bit capacity for drilling concrete and masonry

Drill concrete anchor holes, thru holes, piping and mechanical openings for construction and repair work. Switches to rotary drilling mode for steel and wood.



Hydraulic Model 2 2426 0010
SDS Plus

SAE #8 oil port



Hydraulic Model 2 2418 0010
SDS Max

Second handle position
SAE #8 port for hydraulic hose connection

Closed Center Flow Control Valve

Optional accessory – Item ID: 38632



Item ID: 2 2409 8999 1/2" Chuck for SDS PLUS Rebar Cutters

Item ID: XRDCMKL12 1/2" Chuck for SDS MAX

Hydraulic Pressure Reducing Valves

CS 70350 for reducing earth moving equipment 5000 psi to 2000 psi

2 2406 9900 reduces 5075 psi to 1160 psi

2 2406 9700 reduces 2000 psi to 1160 psi



SDS Drill Bits



Small Masonry Bits
SDS Plus up to 1" dia.

Large Masonry Bits
SDS Max up to 2" dia.

| Pneumatic Hammer Drill Model No. | Blows/Minute (BPM) | Drill Speed (RPM) | Solid Bit Capacity (concrete) | Core Bit Capacity (concrete) | Twist Drill (wood) | Motor Power (HP) | CFM at 90 PSI | Tool System | Dimensions (inches) | Weight (lbs.) |
|----------------------------------|--------------------|-------------------|-------------------------------|------------------------------|--------------------|------------------|---------------|-------------|----------------------|---------------|
| 2 1266 0010* | 0-2000 | 0-950 | 1/2" dia. | 1" dia. | 3/8" dia. | 0.75 | 21 | 1/2" Chuck | 12 x 8 1/2 x 4 | 7 |
| 2 2404 0010 | 0-3000 | 0-625 | 1" dia. | 3" dia. | 3/4" dia. | 0.70 | 21 | SDS Plus | 16 x 8 1/2 x 4 | 11 |
| 2 2404 0030* | 0-3000 | 0-625 | 1" dia. | 3" dia. | 3/4" dia. | 0.70 | 21 | SDS Plus | 16 x 8 1/2 x 4 | 11 |
| 2 2417 0010* | 0-2500 | 0-250 | 2" dia. | 6" dia. | 1 1/4" dia. | 1.60 | 53 | SDS Max | 19 1/2 x 9.8 x 4 1/2 | 26 |

* Underwater model – optional underwater air tool line conditioner to displace moisture, Item ID: 9109. See page 123.

| Hydraulic Hammer Drill Model No. | Blows/Minute (BPM) | Drill Speed (RPM) | Solid Bit Capacity (concrete) | Core Bit Capacity (concrete) | Twist Drill (wood) | Motor Power (HP) | Oil Flow/PSI | Tool System | Dimensions (inches) | Weight (lbs.) |
|----------------------------------|--------------------|-------------------|-------------------------------|------------------------------|--------------------|------------------|-------------------------|-------------|---------------------|---------------|
| 2 2426 0010 | 0-3400 | 0-625 | 1" dia. | 3" dia. | 3/4" dia. | 0.8 | 5.8-13.2 GPM @ 1160 PSI | SDS Plus | 18 x 10 1/4 x 4 | 15 |
| 2 2418 0020** | 0-2500 | 0-250 | 2" dia. | 6" dia. | 1 1/4" dia. | 1.8 | 2.6-13.2 GPM @ 1160 PSI | SDS Max | 16 x 8 1/2 x 4 | 31 |

**Includes 2 2406 9700 Pressure Reducing Valve for 2000 PSI.

** Hydraulic Hammer Drills operate at hydraulic pressures of 1160 PSI max. Pressure reducing valves are available to reduce pressure from 2000 PSI or 5000 PSI. See above. Available with optional closed center.

Woodboring Air Drills, Reversible



Scan to
Learn More

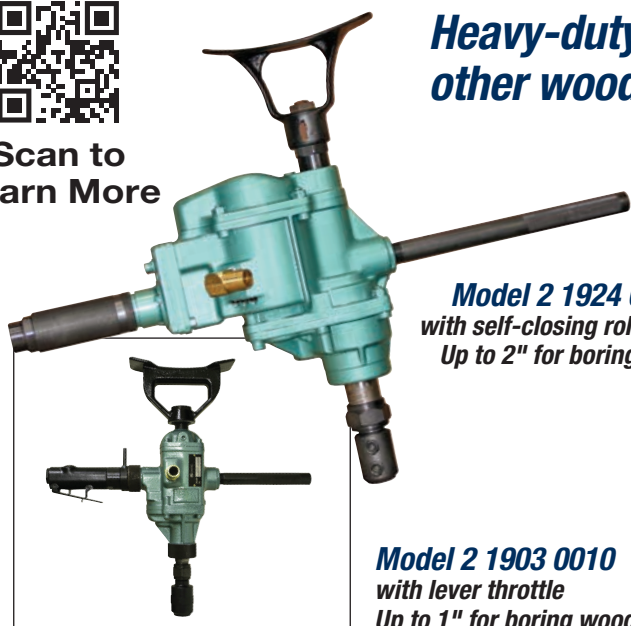

Heavy-duty power for underwater drilling and other wood boring applications



Model 2 1924 0010
with self-closing roll throttle
Up to 2" for boring wood

Model 2 1903 0010
with lever throttle
Up to 1" for boring wood

- Ideal for drilling wood in marine timbers, underwater use and railroad repair work
- Thrust bearing support for long life and efficient operation
- Lever or roll throttle and durable spur gearing
- Breast plate and dead handle included
- Includes threaded exhaust port
- Use underwater with Air Tool Line Conditioner 9109 (shown below)

Accessories and woodboring drill bits from 1/2" dia. to 1 1/2" dia. in lengths from 12" to 36"

| Specifications | Model 2 1903 0010 | Model 2 1924 0010 | Model 2 1932 0010 N |
|-----------------------------|-------------------|-----------------------|-----------------------|
| Capacity in Wood | 1" Diameter | 2" Diameter | 3" Diameter |
| Reversible | Yes | Yes | Yes |
| Power | 2 HP | 3 HP | 3 HP |
| Chuck Style | 1/2" Woodboring | 1/2" Woodboring | 1/2" Woodboring |
| Spindle | Stub Taper | #2 Morse Taper | #3 Morse Taper |
| Free Speed | 750 RPM | 700 RPM | 380 RPM |
| Recommended Hose Size | 1/2" | 1/2" | 1/2" |
| Overall Height | 17 1/2" | 18 1/2" | 18 1/2" |
| Weight | 14 1/2" lbs. | 24 3/4" lbs. | 24 3/4" lbs. |
| Air Inlet Thread | 1/2" ID | 1/2" ID | 1/2" ID |
| Air Exhaust Thread | 1/2" NPT | 1/2" NPT | 1/2" NPT |
| Air Consumption at 90 PSI | 39 CFM | 39 CFM | 39 CFM |
| Optional Geared Drill Chuck | Item ID: DE-99C | Item ID: IBC 22 (MT2) | Item ID: IBC 21 (MT3) |

AirPac Extends life of pneumatic power tools *See page 123 for all Air & Hydraulic Tool Accessories*



Model CSAP-2

- Eliminates air motor downtime caused by water and dirt
- Connections for two tools; max. air flow 185 CFM

- Removes moisture and dirt from air lines; a float valve automatically ejects water and dirt
- Includes automatic oiler; prevents tools from freezing in cold environments

Air Tool Line Conditioner

Underwater air tool conditioner for marine applications. Displaces moisture and inhibits rust/corrosion of air motors.

9109 – 5 Liters



Nut Runners - High Torque

ATEX

Pneumatic and hydraulic: ideal for turning valves, tightening, tapping, reaming, pipe beveling, expanding and more



- Worm gear drive provides high torque – up to 554 ft.-lbs.
- Lightweight and reversible
- Compact angle head allows access to confined spaces



Scan to Learn More



Model 6 1055 0075

Item ID:s pictured above (listed from top to bottom): 6 1055 0075 (with male drive), 6 1055 0010 (female), 6 1014 0075 (with male drive)

Available with Male or Female Square Drives, in a variety of sizes



Male Sq. Drive Head
1/2" or 3/4"



Female Sq. Drive Head
3/4" or 7/8"

Square Drive Accessories



6 1015 7030 – 3/4" Male Square Drive with retaining hole (included with Item ID:s 6 1014 0075, 6 1055 0075 and 6 1056 0075)



6 1017 7940 – 3/4" Male Square Drive with retaining pin



6 1018 7940 – 1/2" Male Square Drive with retaining pin (included with Item ID:s 6 1014 0099, 6 1055 0099 and 6 1056 0099)



6 1016 7940 – 1" Male Square Drive

| Pneumatic Nut Runner Model No. | Square Drive F=Female M=Male | Stall Torque at 90 PSI (ft.-lbs.) | Free Speed (RPM) | Load Speed (RPM) | Power (HP) | CFM at 90 PSI | Side to Center Distance | Length | Weight (lbs.) | Air Connection | Hose ID |
|--------------------------------|------------------------------------|-----------------------------------|------------------|------------------|------------|---------------|-------------------------|--------|---------------|----------------|---------|
| 6 1014 0075* | 3/4" M | 95 | 200 | 100 | 0.9 | 46 | 1" | 22" | 11 | 3/8" NPT | 1/2" |
| 6 1014 0099 | 1/2" M | 95 | 200 | 100 | 0.9 | 46 | 1" | 22" | 11 | 3/8" NPT | 1/2" |
| 6 1055 0075* | 3/4" M | 405 | 40 | 22 | 0.9 | 46 | 1" | 21" | 10 | 3/8" NPT | 1/2" |
| 6 1055 0099 | 1/2" M | 405 | 40 | 22 | 0.9 | 46 | 1" | 21" | 10 | 3/8" NPT | 1/2" |
| 6 1056 0075* | 3/4" M | 133 | 120 | 67 | 0.9 | 46 | 1" | 21" | 11 | 3/8" NPT | 1/2" |
| 6 1056 0099 | 1/2" M | 133 | 120 | 67 | 0.9 | 46 | 1" | 21" | 11 | 3/8" NPT | 1/2" |
| 6 1057 0075* | 3/4" M | 73.5 | 250 | 125 | 0.9 | 46 | 1" | 21" | 11 | 3/8" NPT | 1/2" |
| 6 1057 0099 | 1/2" M | 73.5 | 250 | 125 | 0.9 | 46 | 1" | 21" | 11 | 3/8" NPT | 1/2" |
| 6 1061 0010 | 7/8" F | 405 | 40 | 22 | 0.9 | 46 | 1" | 21" | 11 | 3/8" NPT | 1/2" |

* Also available with 3/4" Female Square Drive – use 0010 instead of 0075 in Item ID:.

| Hydraulic Nut Runner Model No. | Square Drive F=Female M=Male | Drive Torque (ft.-lbs.) | Free Speed (RPM) | Load Speed (RPM) | Power (HP) | Oil Flow (GPM) | Oil Pressure (PSI) | Side to Center Distance | Length | Weight (lbs.) | Connection Quick Couplers |
|--------------------------------|------------------------------------|-------------------------|------------------|------------------|------------|----------------|--------------------|-------------------------|--------|---------------|---------------------------|
| 3 6242 0010* | 3/4" F | 369 | 40 | 22 | 1.6 | 4-13 | 1300-2000 | 1" | 20" | 22 | 1/2" FF |
| 3 6243 0010* | 3/4" F | 125 | 180 | 90 | 1.6 | 4-13 | 1300-2000 | 1" | 20" | 22 | 1/2" FF |

* Also available with 1/2" (3 6242 0099) and 3/4" (3 6242 0075) Male Square Drive

ATEX Directive

ATEX classified power tools ensure a high level of safety in explosive atmospheres

ATEX Directive 94/9/EC defines requirements for controlling explosive atmospheres, as well as the standards for the equipment used in them. An explosive atmosphere is an atmosphere where enough flammable gas, mist, vapor or dust is mixed with air to cause an explosion if ignition occurs.

What is ATEX?

ATEX (ATmospheres EXplosibles) is a directive for those who design, manufacture or sell any equipment intended for use in potentially explosive atmospheres. Technical and quality objectives must be certified by a third-party certification association. The ATEX directive has been a legal requirement for all European Union States since July 2003. The ATEX symbol is recognized internationally, providing assurance to users around the world that the product was manufactured to high levels of safety.

How are ATEX tools classified?

Five elements are used to ensure that a specific piece of equipment is appropriate for its intended purpose and can be safely used in a particular application. These five elements are: 1. Industrial or Mining Application; 2. Equipment Category; 3. Atmosphere; 4. Gas; and 5. Temperature (see chart below).

What types of tools receive ATEX certification?

Pneumatic, hydraulic and electric power tools for construction and industry can be ATEX certified. CS Unitec offers a comprehensive line of power tools for the oil, gas and energy industries. ATEX certified power tools from our line include select models of reciprocating saws, hacksaws, rotary hammer drills, impact wrenches, portable band saws, nut runners, magnetic drills, axial fans and more.

How can I tell if my tool is ATEX certified?

The tool will be marked with the appropriate ATEX classification label and Ex symbol .

| Equipment Group | Equipment Category | Atmosphere | Gas Groups | Temperature <small>(tool surface temp. does not exceed)</small> |
|--|--|--|--|--|
| II Surface Industry | 1 Very High Level of Protection <small>[Zone 0, 1, 2 or 20, 21, 22]</small> | Gc Atmosphere Containing Gas, Vapors or Mist | IIA Propane (acetone, petroleum fuel, ammonia, ethane, methanol, carbon monoxide, propane, n-butane, ethanol, diesel fuel, kerosene, avgas fuel, ethyl nitrite) | T1 842°F/450°C |
| | 2 High Level of Protection <small>[Zone 1, 2 or 21, 22]</small> | Dc Atmosphere Containing Dust | | T2 572°F/300°C |
| | 3 Normal Level of Protection <small>[Zone 2 or 22]</small> | | | T3 392°F/200°C |
| IM Mining Applications (underground and above-ground facilities) | | | IIB* Ethylene (coal gas, ethylene, ethyl oxide, hydrogen sulphide) | T4 275°F/135°C |
| | | | | T5 212°F/100°C |
| | | | | T6 185°F/85°C |

* IIA and IIB are in increasing order of sensitivity to ignition sources, so equipment designed for use in IIB is also safe to use in IIA.

CAUTION: The user is responsible for following all safety regulations (OSHA, etc.) when choosing the appropriate tool for the hazards present.

For ATEX information, visit: <http://ec.europa.eu/growth/sectors/mechanical-engineering/atex/>

For more information and product specifications on CS Unitec's ATEX classified industrial power tools, call 1-800-700-5919 (203-853-9522 international) or email info@csunitec.com.

For a FREE poster explaining Ex zones, visit www.csunitec.com/poster.

Tool Classification Examples:

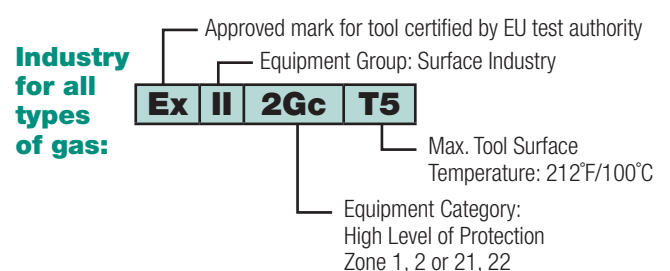
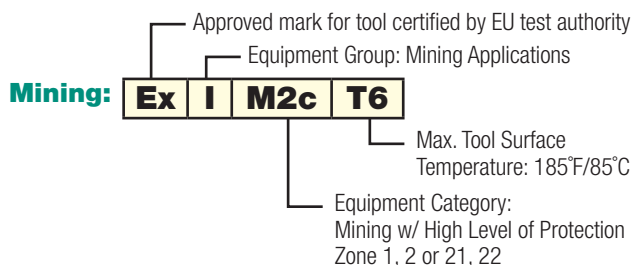
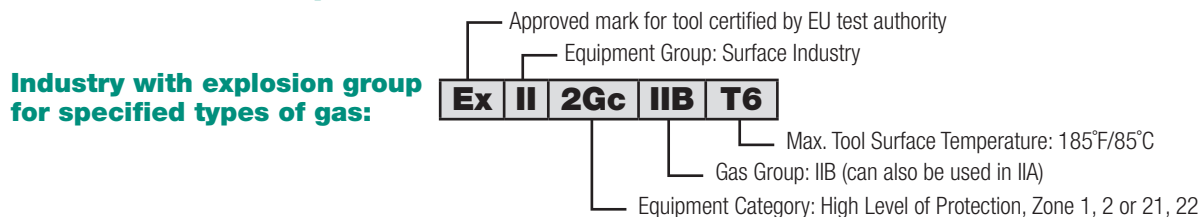

For a complete list of CS Unitec's ATEX tools, visit: www.csunitec.com/specialty/atex-power-tools

UNITEC Surface Finishing Tools & Accessories

The value is in the engineering... the payback is in the performance.™

CS Unitec offers high-performance power tools and abrasive accessories for surface finishing on **STEEL, STAINLESS STEEL, ALUMINUM** and other metals, as well as rigid plastics and wood.

Innovation is the engine of efficiency!™

Innovations in machine design, abrasive materials and production methods have led the way to:

Hollow-core abrasives for linear grinding

The PTX Eco Smart is a linear surface finishing machine with a finned shaft for quick abrasive changing – simply slide on the abrasives and they secure automatically. This saves time and the abrasive wheels cost less. (Patented!)



5/8"-11 SPEED NUT changeover (Item ID: 65008-1) The **EASY-LOCK SPEED NUT** allows you to change flap discs in seconds, without tools. It is easily hand tightened and eliminates the need for wrenches or expensive hubs. (Patented!)

Belts with buttonhole fastening system for grinding and polishing closed pipe constructions. (Patented!)



Important advancements in flap disc technology

- PLANTEX® high-tech hemp fiber compound (Patented!)
- POLY-MAGIC-WHEEL for dry polishing inside corners
- MAGNUM® FLEECE TOP for surface conditioning, fine finishing and polishing



Safer and more efficient!

CS Unitec is the source for flap discs and abrasives that are free of fiberglass, mineral fibers and epoxy resin. They offer superior material removal, longer service life and smoother ergonomic handling.

Better for the environment!

The fiber in the high-tech PLANTEX® compound is derived from the hemp plant – a sustainable raw material which counteracts greenhouse emissions as it grows. The PTX hollow-core abrasives not only improve production efficiencies, but also minimize pollution from production to waste disposal... no plastic insert!

Better for your bottom line!

In addition to their time-saving features and high quality, flap discs and abrasives from CS Unitec can save you money – their cost of production is lower, their quality is among the best and they offer superior service life. Hollow-core abrasive wheels from CS Unitec are more affordable than traditional solid-core abrasives since they can be produced from less raw material. These new hollow-core abrasive wheels can also be used on traditional finishing machines with the aid of a simple core adapter Item ID: 42004 (see page 86.)



Industrial hemp fiber is an almost ideal base material for backing plates of flap discs... and it is a renewable resource!



View product demonstrations at www.csunitec.com.

Surface Finishing Tools and Abrasives Index:

Linear Grinding & Finishing Systems p. 86-93

PTX Eco Smart – electric p. 86-88
 Abrasives, Belts, Brushes, Grinding Wheels, etc. p. 89-93

All-in-One Angle Grinder/Finishing, Blending & Polishing Machine p. 94-95

VARILEX® Speed-controlled Grinder/Finisher/Polisher – 4" to 7" diameter p. 94-95

Flap Discs and Abrasives for Grinding, Blending and Finishing p. 96-101

FLAP DISCS - SUNFIRE, SPITFIRE, WELD-EX, ALUMINUM, RAZORFLAP p. 96-97
 FIX HOOK & LOOP ABRASIVES & SYSTEM – flexible discs for finishing p. 98-99
 POLY-MAGIC UNITIZED WHEEL – for dry polishing in corners p. 100
 MAGNUM® TOPMIX – for increased material removal p. 100
 MAGNUM® FLEECE TOP – for conditioning, finishing and polishing p. 101
 MAGNUM® CLEAN – for pore-deep cleaning of metals p. 101

Pipe Grinders/ Polishers and Multifunctional Systems p. 102-105

PIPE-MAX – weld seam grinder and pipe sander/ polisher p. 102
 King-BOA tube/ rail sander & polisher p. 103-104
 GLADIUS® 1800 Multifunctional Grinder p. 104
 Abrasives & Accessories for Pipe Sanders & Grinders p. 105

Deburring, Beveling and Faceting Machines p. 106-109

ROLEI® BE 5 Sheet Metal Deburring Machine p. 106
 ROLEI® PEF 500 Beveling & Deburring Machine p. 107
 ROLEI® EF 165 Beveling & Deburring Machine p. 107
 ROLEI® EF 115 Handheld Deburring & Faceting Machine p. 107
 Portable Beveling Machines p. 108-109



PTX ECO SMART



PLANTEX®



VARILEX®

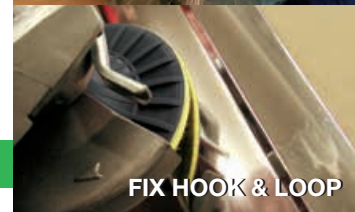

FIX HOOK & LOOP



DEBURRING



BEVELING

Safety Guidelines

Use all products according to the safety regulations of OSHA and directives by ANSI (American National Safety Institute) B7.1, European DIN EN 13743 and all other applicable international safety standards.

PTX ECO SMART

The professional linear finishing system for hard, continuous use.

A revolution in linear grinding! Simply slide on the abrasives and they secure themselves automatically when the machine turns. Fast and easy!



Press the spindle lock and simply slide on the abrasive wheels or brushes, turning in the correct direction onto the finned shaft. They will be secured automatically.



Grinding in corners is easy – simply slide the abrasive wheel on the finned shaft a little towards the outside.



Even narrow abrasive wheels can be used on the PTX Eco Smart and positioned freely on the finned shaft (no spacer rings required).

LINEAR GRINDING SYSTEM



Adjustable handle for right and left-handed users. Anti-vibration handle for comfortable, fatigue-free working.



Simple speed control during operation. Tachogenerator for stable speeds.



QUICK-LOCK cable for fast, easy replacement if cable is damaged. 13 ft., included. **Item ID: 52004-2**



Infinitely adjustable cover guard with securing points for the extraction cover. **Item ID: 40005**

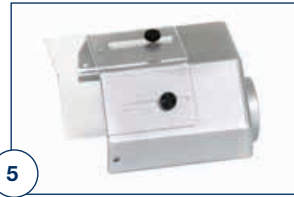

Extended polycarbonate cover guard for grinding wheel widths up to 6". **Item ID: 52706**



Hollow core shaft adapter for roller wheel widths up to 6" and vibration-free operation. **Item ID: 42004**



Item ID: PTX Eco Smart

110 Volt or 220 Volt



Perfect finishes on large surfaces, with no shadows or streaks.



www.csunitec.com

New abrasive mounting system saves time, reduces cost and eliminates vibration.

PTX Eco Smart is a multi-functional grinding and polishing system for flat surfaces and open or closed pipe constructions.

- Grind from coarse to shadow-free matte finish, up to a mirror polish
- Remove welds, deep scratches, oxidation and rust
- Ideal for stainless steel, steel and nonferrous metals including aluminum, brass, bronze and copper, as well as wood and rigid plastic
- Complete line of grinding wheels, belt sleeves, special brushes, polishing and maintenance abrasives available
- Balanced straight-line handling, high torque and electronic speed control
- Abrasive mounting system allows quick changeover, vibration-free operation and 100% concentricity
- Core-free abrasives save money and produce less waste



Satin finishing using interleaf fleece wheel.



A wide selection of hollow-core abrasives is available for the PTX Eco Smart. The lack of a core insert means that the abrasives are lighter, easier to use and less expensive.

PTX Eco Smart Specifications

| | | |
|--------------------|--|--|
| Item ID: | PTX ECO SMART | |
| Motor Power | 15 Amp (1710 Watts); 110 Volt/50/60Hz (Also available: 230 Volt / 50 Hz) | |
| Speed Control Dial | Variable speed control from 1000 to 3800 RPM with tachogenerator for constant speed, even under load | |
| Wheel Width | 2", 4" or 6" wide abrasives | |
| Wheel Diameter | up to 4 1/2" | |
| Weight | 7.25 lbs. | |
| Standard Equipment | 4" Interleaf (combi) wheel – Item ID: 47312 Shaft Adapter – Item ID: 42004 | |

Accessories



Hollow-core Shaft Adapter

Allows user to utilize more economical hollow-core abrasives on traditional surface finishers. Fits 3/4" dia. x 4" long shaft and 1/4" keyway(s). Overall diameter of adapter is 1-3/4" (45mm)
Item ID: 42004

NEW Battery Powered PTX

Same reliable power - No restrictions

Item ID: 40351U (Battery and Charger included)



Item ID: 50463 (Battery)

Item ID: 50474U (Charger)



A range of professional PTX Eco Smart kits is available for a variety of applications. See page 88 for more information.

PTX Eco Smart Kits

PTX Professional Kit For Metalworking

This set comes in a strong, impact-resistant transport case and contains everything you need for shadow-free industrial finishes. Match or create any finish up to a mirror finish on metals. Prevent marks and fingerprints with newly developed cleaning products and preservatives.

Item ID: 47003-5A



PTX Professional Kit for Metalworking includes:

- 1 PTX Eco Smart machine
- 1 40 grit flap wheel, 4" x 4-1/8" (Item ID: 47211)
- 1 80 grit Interleaf (Combi) wheel, 4" x 4-1/8" (Item ID: 47312)
- 1 Expansion roller, 3-1/2" x 4" (Item ID: 47005)
- 2 80 grit grinding belt sleeve, 3-1/2" x 4" (Item ID: 42080)
- 1 Fine fleece (Nonwoven) sleeve, 3-1/2" x 4" (Item ID: 42012)
- 1 Medium fleece (Nonwoven) sleeve, 3-1/2" x 4" (Item ID: 42011)
- 2 D45 TZ Pyramid sleeves, 3-1/2" x 4" (Item ID: 42245)
- 2 D30 TZ Pyramid sleeves, 3-1/2" x 4" (Item ID: 42230)
- 2 D16 TZ Pyramid sleeves, 3-1/2" x 4" (Item ID: 42216)
- 2 D06 TZ Pyramid sleeves, 3-1/2" x 4" (Item ID: 42206)
- 3 SuperPolish sleeves, 3-1/2" x 4" (Item ID: 42013N)
- 1 Belt driving roller (Item ID: 47006)
- 2 80 grit grinding belts, 1.2" x 24" (Item ID: 49080)
- 1 Medium fleece (Nonwoven) belt, 1.2" x 26" (Item ID: 49002)
- 2 D45 TZ Pyramid belts, 1.2" x 24" (Item ID: 49345)
- 2 D30 TZ Pyramid belts, 1.2" x 24" (Item ID: 49385)
- 2 D16 TZ Pyramid belts, 1.2" x 24" (Item ID: 49386)
- 2 D06 TZ Pyramid belts, 1.2" x 24" (Item ID: 49306)
- 3 SuperPolish belts, 1.2" x 26" (Item ID: 49004N)
- 1 Mini high gloss polishing paste, pink (Item ID: 40015T)
- 2 Big polishing pastes, white and blue
[Item ID: 40013 (white) Item ID: 40014 (blue)]
- 1 PTX Brightex® scatter can (Item ID: 40029)
- 5 Microfiber cloths (Item ID: 40031)
- 1 Brilliance-Clean spray bottle (Item ID: 40050)
- 1 INOX-Protect spray bottle (Item ID: 40040)

PTX Basic Kit for Metal

Basic set for coarse finishing to #4 finish on flat surfaces and pipes.

Item ID: 47003A



PTX Basic Kit for Metal includes:

- 1 PTX Eco Smart machine
- 1 Carrying Case (Item ID: 40008)
- 1 60 grit flap wheel, 4" x 4-1/8" (Item ID: 47212)
- 1 80 grit Interleaf (Combi) wheel, 4" x 4-1/8" (Item ID: 47312)
- 1 Expansion roller, 3-1/2" x 4" (Item ID: 47005)
- 1 Medium fleece (Nonwoven) sleeve, 3-1/2" x 4" (Item ID: 42011)
- 1 Belt driving roller (Item ID: 47006)
- 1 80 grit grinding belt, 1.2" x 24" (Item ID: 49080)
- 1 Medium fleece (Nonwoven) belt, 1.2" x 26" (Item ID: 49002)
- 1 40 grit grinding belt, 3.6" x 4" (Item ID: 42040)
- 1 60 grit grinding belt, 3.6" x 4" (Item ID: 42060)
- 1 80 grit grinding belt, 3.6" x 4" (Item ID: 42080)
- 1 120 grit grinding belt, 3.6" x 4" (Item ID: 42120)

PTX Kit For Woodworking

The complete set for treating wooden surfaces. Strong transport case with PTX Eco Smart and a range of brush wheels for various wood structures. Suction cover for extracting grinding dust particles.

Item ID: 40004-3A



PTX Basic Kit for Woodworking includes:

- 1 PTX Eco Smart machine
- 1 Carrying Case (Item ID: 40008)
- 1 Suction cover (Item ID: 40005)
- 1 Spacer ring (Item ID: 40007)
- 1 PTX stranded wire wheel (Item ID: 46301)
- 1 Bristle wheel (Item ID: 46101)
- 1 Fiber wheel (Item ID: 46400)

PTX Grinding Wheels for Coarse and Fine Finishing

PTX abrasives from CS Unitec are made according to high quality standards. A unique production process guarantees high concentricity for vibration-free grinding – ideal for fatigue-free working and perfect surface finishes with no transitions or shadows. **Simply try it!** You will be surprised how much smoother a PTX grinding wheel or brush wheel is.



PTX FLEECE (Nonwoven) Wheel

Flexible nylon fleece impregnated with abrasives for a first-class finish. Produces shadow-free matte, satin and polished finishes. For removing oxidation on stainless steel and nonferrous metals and also suitable for smoothing wooden surfaces. Very high fleece content by fleece compression.

Diameter: 4"
Width: 2", 4-1/8" or 6"
Grit: 60, 80, 180, 280, 400, 600



PTX Interleaf (Combi) Wheel

Nylon fleece combined with abrasive flaps for matte finishing, burnishing and removing light scratches, oxidation and handling marks on stainless steel and all metals. For removing old paint on wood while smoothing at the same time.

Diameter: 4"
Width: 2", 4-1/8" or 6"
Grit: 60, 80, 180



PTX Flap Wheel

With radial abrasive cloth flaps in various grit sizes for removing rust, oxidation layers, minor scratches and for the regraining and burnishing of metals.

Diameter: 4"
Width: 2" or 4-1/8"
Grit: 24, 40, 50, 60, 80, 120, 180, 240



PTX CLEAN Wheel

Made of hard-textured, nonwoven fleece for cleaning and descaling welds, pore-deep removal of rust, oxidation and coatings, cleaning beams, bricks, etc. Produces an effective linear finish on stainless steel.

Diameter: 4"
Width: 2" or 4"
Grit: Medium



PTX GUM Wheel

Soft rubber impregnated with abrasive grit for the removal of minor scratches. Ideal for a bright, decorative linear finish on stainless steel and nonferrous metals and for smoothing wooden fibers.

Diameter: 4"
Width: 2" or 4-1/8"
Grit: 60, 180

HOLLOW-CORE ABRASIVES HAVE MANY ADVANTAGES:

- Easy to mount – simply slide on and off
- 100% concentricity – no vibration
- Lower cost and higher productivity!

We continue to carry abrasives with core inserts.
Contact us for more information.

PTX Fleece Nonwoven Wheels

| Item ID: | Grit | Size (dia. x width) |
|----------|------|--------------------------------------|
| 47411 | 60 | 4 ¹ / ₈ " x 4" |
| 47412 | 80 | 4 ¹ / ₈ " x 4" |
| 47413 | 180 | 4 ¹ / ₈ " x 4" |
| 47414 | 280 | 4 ¹ / ₈ " x 4" |
| 47415 | 400 | 4 ¹ / ₈ " x 4" |
| 43601* | 600 | 4 ¹ / ₈ " x 4" |
| 47401 | 60 | 4 ¹ / ₈ " x 2" |
| 47402 | 80 | 4 ¹ / ₈ " x 2" |
| 47403 | 180 | 4 ¹ / ₈ " x 2" |
| 47404 | 280 | 4 ¹ / ₈ " x 2" |
| 47405 | 400 | 4 ¹ / ₈ " x 2" |
| 47422 | 80 | 4 ¹ / ₈ " x 6" |
| 47423 | 180 | 4 ¹ / ₈ " x 6" |

* Keyed shaft

PTX Interleaf (Combi) Wheels

| Item ID: | Grit | Size (dia. x width) |
|----------|------|---------------------|
| 47311 | 60 | 4" x 4" |
| 47312 | 80 | 4" x 4" |
| 47313 | 180 | 4" x 4" |
| 47301 | 60 | 4" x 2" |
| 47302 | 80 | 4" x 2" |
| 47303 | 180 | 4" x 2" |
| 47322 | 80 | 4" x 6" |
| 47323 | 180 | 4" x 6" |

PTX Flap Wheels

| Item ID: | Grit | Size (dia. x width) |
|----------|------|--------------------------------------|
| 47211 | 40 | 4" x 4 ¹ / ₈ " |
| 47212 | 60 | 4" x 4 ¹ / ₈ " |
| 47213 | 80 | 4" x 4 ¹ / ₈ " |
| 47214 | 120 | 4" x 4 ¹ / ₈ " |
| 47215 | 180 | 4" x 4 ¹ / ₈ " |
| 47201 | 24 | 4" x 2" |
| 47202 | 40 | 4" x 2" |
| 47204 | 60 | 4" x 2" |
| 47205 | 80 | 4" x 2" |
| 47206 | 120 | 4" x 2" |
| 47207 | 180 | 4" x 2" |
| 47208* | 240 | 4" x 2" |

* Keyed shaft

PTX CLEAN Wheels

| Item ID: | Grit | Size (dia. x width) |
|----------|----------------|---------------------|
| 47511 | Medium (black) | 4" x 4" |
| 40018A* | Medium (black) | 4" x 2" |

* Keyed shaft

PTX GUM Wheels

| Item ID: | Grit | Size (dia. x width) |
|----------|------|--------------------------------------|
| 45061* | 60 | 4" x 4 ¹ / ₈ " |
| 45181* | 180 | 4" x 4 ¹ / ₈ " |
| 45180* | 180 | 4" x 2" |

* Keyed shaft



Expansion Roller

Use with sanding belts, fleece and felt sleeves. The sleeves are simply pushed over the expansion roller and held securely in place by the centrifugal force. **3-1/2" dia. x 4" wide - Item ID: 47005**

TIPS & TRICKS

Expansion Roller - Hard Rubber

Internal expansion slots now allow easier sleeve replacement and improved adjustment to the workpiece, as well as vibration absorption and concentricity.

Item ID: 47005

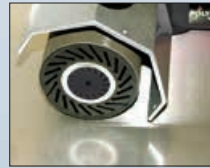

Belt Sleeves for Expansion Roller



PTX Zirconium Grinding Belt Sleeve

Made of zirconium. Removes deep scratches and grinds weld seams on metals. Far less rework is required as a result of using the time-saving linear grinding technique.

3-1/2" dia. x 4" wide
Grit: 40, 60, 80, 120, 150, 180



PTX Ceramic Grinding Belt Sleeve

High-performance ceramic aluminum oxide grain. Increased removal rate and longest life for highest productivity. Excels in all metals.

3-1/2" dia. x 4" wide
Grit: 40, 60, 80



PTX Pyramid Sleeve

New abrasive cloth with pyramid-shaped grit structure. High material removal while producing a very fine finish, reducing the amount of work required when compared to grinding belt sleeves and fleece sleeves. Ideal for pre-polishing for fine mirror finishes and removing scratches and spot welds.

Even roller scale can be removed easily.

3-1/2" dia. x 4" wide
Grit: D100/220, D65/280, D45/400, D30/600, D16/1200, D06/2000



PTX Fleece "Nonwoven" Sleeve

Nylon impregnated with abrasive grit for removing minor to medium scratch marks and oxidation coatings, matte and satin finishing and deburring applications.

3-1/2" dia. x 4" wide
Grit: Coarse, Medium, Fine, Superfine



The expansion roller is helpful when grinding large areas and removing large welds.

PTX Zirconium Grinding Belt Sleeves

| Item ID: | Grit | Size (dia. x w) | Quantity |
|----------|------|-----------------|-------------|
| 42040 | 40 | 3 1/2" x 4" | 10 per pack |
| 42060 | 60 | 3 1/2" x 4" | 10 per pack |
| 42080 | 80 | 3 1/2" x 4" | 10 per pack |
| 42120 | 120 | 3 1/2" x 4" | 10 per pack |
| 42150 | 150 | 3 1/2" x 4" | 10 per pack |
| 42180 | 180 | 3 1/2" x 4" | 10 per pack |

PTX Ceramic Grinding Belt Sleeves

| Item ID: | Grit | Size (dia. x w) | Quantity |
|----------|------|-----------------|-------------|
| 42440 | 40 | 3 1/2" x 4" | 10 per pack |
| 42460 | 60 | 3 1/2" x 4" | 10 per pack |
| 42480 | 80 | 3 1/2" x 4" | 10 per pack |

PTX Pyramid Sleeves

| Item ID: | Grit | Size (dia. x w) | Quantity |
|----------|----------|-----------------|-------------|
| 42292 | D100/220 | 3 1/2" x 4" | 10 per pack |
| 42293 | D65/280 | 3 1/2" x 4" | 10 per pack |
| 42294 | D45/400 | 3 1/2" x 4" | 10 per pack |
| 42295 | D30/600 | 3 1/2" x 4" | 10 per pack |
| 42296 | D16/1200 | 3 1/2" x 4" | 10 per pack |
| 42297 | D06/2000 | 3 1/2" x 4" | 10 per pack |

PYRAMID GRIT COMPARISON TABLE

| Corresponds to grit size | D100 | D65 | D45 | D30 | D16 | D06 |
|--------------------------|------|-----|-----|-----|------|------|
| | 220 | 280 | 400 | 600 | 1200 | 2000 |

PTX Fleece "Nonwoven" Sleeves

| Item ID: | Grit | Size (dia. x w) | Quantity |
|----------|------------------|-----------------|------------|
| 42010 | coarse (brown) | 3 1/2" x 4" | 4 per pack |
| 42011 | medium (red) | 3 1/2" x 4" | 4 per pack |
| 42012 | fine (blue) | 3 1/2" x 4" | 4 per pack |
| 42009 | superfine (grey) | 3 1/2" x 4" | 4 per pack |

FLEECE COMPARISON TABLE

| Corresponds to grit size | Coarse (brown) | Medium (red) | Fine (blue) | Superfine (grey) |
|--------------------------|----------------|--------------|-------------|------------------|
| | 80 | 180 | 280 | 400 |

TIPS & TRICKS



To remove the grinding sleeve, place the expansion roller on a round object that is slightly smaller than the roller. Then push the sleeve down slightly using both hands.

Special Brushes for Metals, Wood and Hard Plastics



PTX Stranded Wire Wheels
Sturdy steel wire brush. For deburring, rust removal, roughing and cleaning metal. For brushing out soft annual rings on timber, leaving a rough rustic effect.
4" dia. x 2-7/8" wide – Item ID: 46301*
4" dia. x 1" wide – Item ID: 47702*
* Requires spacer ring Item ID:40007



PTX Bristle Wheel
Elastic nylon brush impregnated with abrasive grit. For roughing and deburring metal, as well as creating a rustic effect with even annual ring transitions on timber.
4" dia. x 2-7/8" wide – Item ID: 46101*
4" dia. x 1" wide – Item ID: 46102N*
* Requires spacer ring Item ID:40007



PTX Stainless Steel Wire Wheels
Elastic stainless steel wire brush. For cleaning welds, deburring, removing rust, roughing and removing coatings.
4" dia. x 2-7/8" wide – Item ID: 47721*
4" dia. x 1" wide – Item ID: 46202N*
* Requires spacer ring Item ID:40007



PTX Fiber Wheel
Elastic fiber brush. For polishing stained wood, satin finishing, pore-deep dust removal and cleaning applications.
4" dia. x 4" wide – Item ID: 46400

Note: Above wheels are configured for keyed shaft. Hollow-core shaft adapter not necessary.



Stranded wire wheel for creating a rustic effect on wood



Cotton Buffing Wheel
Cotton yarn wheel for use with compounds. Produces a very bright high mirror finish. Use on flat, contoured or irregular surfaces.



4" dia. x 2" wide
Item ID: CS 2405*
4" dia. x 4" wide
Item ID: CS 2410
4" dia. x 6" wide
Item ID: CS 2420

* Requires spacer ring Item ID:40007

Abrasives for Polishing to High-Gloss and Mirror Finish



PTX Felt Sleeve
Made of soft merino (endless) for polishing large stainless steel and nonferrous surfaces quickly to a mirror finish. Also suitable for hard plastics. Must be used with the expansion roller.
3-1/2" dia. x 4" wide (4 per pack)
Item ID: 42013



PTX SuperPolish Sleeve
Revolutionary special fleece produces perfect brilliant, shadow-free mirror finishes on stainless steel and nonferrous metal surfaces using polishing compounds (white and blue) and pink polishing cream. SuperPolish fleece is absorbent, does not smear and saves significant work time. Must be used with the expansion roller.
3-1/2" dia. x 4" wide (4 per pack)
Item ID: 42013N

Poly-PTX Cotton Rings

Fleece rings for polishing narrow or uneven stainless steel and nonferrous metal surfaces using polishing compounds (white and blue) and pink polishing cream. A separate Poly-PTX Cotton Ring must be used for each compound or cream so as not to mix different compound grits.



For polishing narrow or uneven stainless steel surfaces:
100mm x 12mm (4" dia. x 1/2" wide), 8 per pack, Medium Item ID: 40019M
100mm x 12mm (4" dia. x 1/2" wide), 8 per pack, Soft Item ID: 40019-T

For polishing aluminum, brass and other nonferrous metals:
100mm x 12mm (4" dia. x 1/2" wide)
Item ID: 250 521

See page 92 for pre-grinding and polishing compounds, mirror finish creams, cleaners and protective sprays for finished metal surfaces.

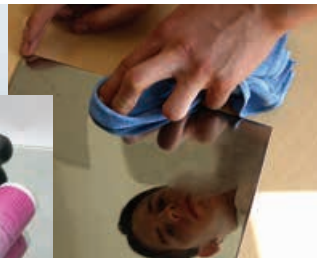

Polishing and Maintenance Products (cont'd)



PTX Pre-grinding & Polishing Compound

Essential for polishing all metals, including stainless steel, aluminum, etc.

PTX WHITE pre-polishing compound (23 oz.) – **Item ID: 40013**

PTX BLUE finishing compound (23 oz.) – **Item ID: 40014**

PTX WHITE and BLUE mini pastes (approx 4.2 oz. ea.) – **Item ID: 40009**



PTX Brightex® Softclean Powder (non-caustic)

For removing cream and compound residues. Scatter on the surface and wipe off with a microfiber cloth.

Aluminum scatter container with Brightex® (approx. 7 oz.) – **Item ID: 40029**

Bag, 2.2 lbs. – **Item ID: 40028**

Scatter container only – **Item ID: 40020**



PTX Polishing Cream, Pink

For high reflective finishing. Produces a perfect mirror finish on stainless steel and nonferrous metals when used with the SuperPolish Sleeve or Belt.

Miniature tube, 2 oz. – **Item ID: 40015T**

Can, 2.2 lbs. – **Item ID: 40015**

Microfiber Cloths

For pore-deep cleaning and even distribution of maintenance products and polishes. Our microfiber cloths produce a top finish on all materials.

Size: 13" x 14", package of 25 – **Item ID: 40031**



INOX-Protect (hard sealant) Protects finished and polished metal surfaces (stainless steel, steel, aluminum, brass, copper, etc.) with a clear, dry adhesive film. Removes fingerprints and other dirt.

Canister (w/ spray bottle), 1.3 gal. – **Item ID: 40041**

Spray bottle, 17 oz. **Item ID: 40040**



Brilliance-Clean

For streak- and residue-free cleaning of all surfaces, including stainless steel, steel, aluminum, brass and copper. Brilliance-Clean is not harmful to plastics, wood or coated surfaces. Remove fingerprints, dust, compound residue, minor oil and grease marks and adhesive residue. Evaporates quickly without leaving residue.

Canister (w/ spray bottle), 1.3 gal. – **Item ID: 40051**

Spray bottle, 17 oz. **Item ID: 40050**



POLY Protection (oil film)

For cleaning and preserving finished and polished stainless steel and nonferrous metal surfaces. Protects against shadows and finger and water marks for a long time. Spray on and rub off with a microfiber cloth. Produces a darker effect on finished surfaces.

Canister (w/ spray bottle), 1.3 gal. **Item ID: 40012**

Spray bottle, 17 oz. **Item ID: 40011**

TIPS & TRICKS

A perfect mirror finish on stainless steel

The newly developed grinding and polishing system, featuring special **TZ Pyramid** and **SuperPolish** fabrics from CS Unitec, produces a perfect mirror finish quickly and in just a few steps.



Step 1 - Pre-grinding

Prepare with **TZ Pyramid** sleeve grit D45 (possibly D65) to remove mill skin, scratches and minor unevenness.



Step 2 - Intermediate grinding

Rework with **TZ Pyramid D30** and complete with **TZ Pyramid D16**. Use very little grinding pressure and grind perpendicular and diagonally.



Step 3 - Mirror finish polish

Use the **SuperPolish** sleeve with **white polishing paste**, then with **blue polishing paste**. Use a different sleeve for each paste grit. Polish diagonally. For a high-gloss finish, use the **SuperPolish** sleeve with the **pink high-gloss polishing cream**. Polish in one direction only.

Tip: After each step, remove the compound residue from the workpiece with **PTX Brightex® Softclean Powder** and a **microfiber cloth**.

The result... a brilliant mirror finish!



Maintain and protect finished or polished stainless steel surfaces.

Compound and cream residues can be removed using **PTX Brightex® Softclean powder**. Simply scatter on the softclean powder and wipe it off using a microfiber cloth.

Compound residues, fingerprints, dust, minor oil and grease marks and adhesive residue can be removed effortlessly with **Brilliance-Clean**. Any residue will evaporate immediately.

To protect finished or polished metal surfaces, spray **INOX-Protect** on the surface, rub off with a microfiber cloth, wipe the surface dry and then polish briefly. The surface will be protected by a dry, invisible film for several weeks. Polished finishes will not be darkened by this product.

Abrasives for Pipe Constructions – Open or Closed

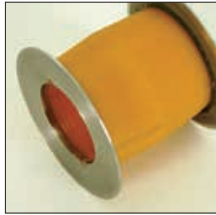

PTX Grinding Belt Roller with stainless steel flanges
For use with grinding, fleece, SuperPolish and felt belts. The belt roller is made of wear-resistant soft Vulculan with stainless steel discs on the sides. The surface is grooved to ensure that the abrasive belt does not slip.
Diameter: 3.5" x 2.8" Item ID: 47006

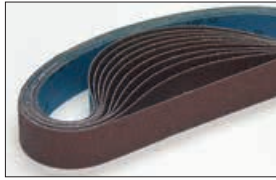

PTX Grinding Belt in high-quality aluminum oxide (closed)
For coarse and initial grinding, rust removal and smoothing round metal pipes. For use with grinding belt rollers. For use on closed pipe constructions, see TIPS & TRICKS below. **Dimensions: 1.2" x 24"**
Grit: 40, 60, 80, 120, 150, 180, 240
See ordering information at right.



PTX TZ Pyramid Belt (closed)
Abrasive fabric with pyramid-shaped grit structure for removing scratches, roller scale and spot welds. TZ Pyramid belts allow high material removal while producing a very fine finish. They are ideal for initial grinding before polishing to a mirror finish. Because grit fineness is increased slowly, it is possible to omit several operations. Use with grinding belt rollers. For use on closed pipe constructions, see TIPS & TRICKS below.
Dimensions: 1.2" x 24", Grit: D65, D45, D30, D16, D06
See ordering information at right.



PTX Fleece Nonwoven Belt (open)
Buttonhole fastening system for fine grinding and pre-polishing open and closed pipe constructions and handrails. The fleece belt can be opened and closed as often as necessary. For use with grinding belt rollers. International patent and design protected.
Dimensions: 1.2" x 26", Grit: coarse, medium, fine, superfine. See ordering information at right.

With buttonhole – **PATENTED!**



PTX Felt Belt (open)
Made of merino felt with buttonhole fastening system for polishing open and closed pipe constructions and handrails. The polishing belt can be opened and closed as often as necessary. Use with grinding belt rollers and our polishing compounds and creams. Use a separate felt belt for each compound and cream grit - do not mix grits. International patent and design protected.
Dimensions: 1.2" x 26" Item ID: 49004



PTX SuperPolish Belt (closed)
For a perfect mirror finish on pipe constructions and handrails. SuperPolish is a new, special micro fleece that produces a perfect, brilliant mirror finish on stainless steel and nonferrous metals. Smears and shadows are eliminated when used with our polishing compounds (white and blue) and pink cream. SuperPolish is absorbent and saves time. Use with grinding belt rollers.
Dimensions: 1.2" x 26" (not available with buttonhole fastening system) Item ID: 49004N

PTX Grinding Belts (Aluminum Oxide)

| Item ID: | Grit | Size (w x l) | Quantity |
|----------|------|--------------|-------------|
| 49040 | 40 | 1.2" x 24" | 10 per pack |
| 49060 | 60 | 1.2" x 24" | 10 per pack |
| 49080 | 80 | 1.2" x 24" | 10 per pack |
| 49120 | 120 | 1.2" x 24" | 10 per pack |
| 49150 | 150 | 1.2" x 24" | 10 per pack |
| 49180 | 180 | 1.2" x 24" | 10 per pack |
| 49240 | 240 | 1.2" x 24" | 10 per pack |

PTX TZ Pyramid Belts

| Item ID: | Grit | Size (w x l) | Quantity |
|----------|----------|--------------|-------------|
| 49365 | D65/280 | 1.2" x 24" | 10 per pack |
| 49345 | D45/400 | 1.2" x 24" | 10 per pack |
| 49330 | D30/600 | 1.2" x 24" | 10 per pack |
| 49316 | D16/1200 | 1.2" x 24" | 10 per pack |
| 49306 | D06/2000 | 1.2" x 24" | 10 per pack |

PTX Fleece Nonwoven Belts (open)*

| Item ID: | Grit | Size (w x l) | Qty. |
|----------|------------------|--------------|------|
| 49001 | coarse (brown) | 1.2" x 26" | 1 |
| 49002 | medium (red) | 1.2" x 26" | 1 |
| 49003 | fine (blue) | 1.2" x 26" | 1 |
| 49007 | superfine (grey) | 1.2" x 26" | 1 |

* Feature buttonhole fastening system



PTX Special Adhesive Tape
Integrated glass fabric for joining grinding belts. Strong, heat-resistant adhesive. Join PTX grinding and TZ Pyramid belts for use on closed pipe constructions. Wrap tape around

entire length of grinding belt, overlapping approximately 370°.
Dimensions: 1" x 165' Item ID: 49000



INOX Miter Tape
Protect adjacent finishes when grinding. Self-adhering 304 Stainless tape for use when creating distinct edges on finishes. Excellent for creating mitered corners. Easily cut with scissors, fast application and residue-free removal.

Minimal thickness for accurate grinding lines.
Dimensions: One roll measures 6" x 8.2 ft. Item ID: 40070

▶ TIPS & TRICKS

Grinding and polishing closed pipe constructions

Fleece and felt belts with the patented buttonhole fastening system are ideal for working on closed pipe constructions and handrails. The grinding belt can be placed over the pipe and closed or opened again in a twist using the buttonhole system. Changing a belt is quick and easy. The belt can be opened and closed as often as required.

Closed belts such as the high-quality aluminum oxide belt or the TZ Pyramid belt must be cut open to work on closed pipe constructions. Place the belt over the pipe and join using our special adhesive tape (Item ID: 49000) over the entire length (approx. 370°).



VARILEX® 1802 HT Professional

The most powerful speed-controlled angle surface finishing and blending tool in its class.

Variable speed from 2400 to 8900 RPM, 15 Amp (1710 W) power, disc change in seconds without tools. For disc diameters up to 7".



VARILEX® is designed to efficiently maximize the capabilities of flap, grinding and cutting discs and the Hook & Loop system.



INDUSTRY'S MOST POWERFUL BLENDING & FINISHING TOOL!

Optimal speed setting for a range of grinding and polishing applications, yielding perfect results every time!

NEW

Battery Powered VARILEX

Same reliable power - No restrictions

Item ID: **65282** (Battery and Charger included)



Item ID: 50463 (Battery)

Item ID: 50474U (Charger)

FLEXIBLE SHAFT - The new flexible drive shaft can now upgrade the VARILEX® to a powerful professional drive motor for all applications. See page 95 for details.



More than just an angle grinder – the most powerful single-handed multi-function machine available!



Change discs in seconds, without tools.

The VARILEX® has an infinitely adjustable speed between 2400 and 8900 RPM, for applications from grinding to blending, pre-polishing and polishing

- Ideal for use with both flap discs and polishing discs, as well as grinding and cutting wheels
- Balanced handle ensures fatigue-free grinding
- Tachogenerator keeps speed constant, even when grinder is operating at full load or low speeds
- Variable-speed control doubles disc service life, prevents glazing of disc and workpiece heat deformation and reduces noise level
- Motor design allows exceptional performance at low RPM – without motor overheating or burnout
- EASY-LOCK clamping nut and spindle lock allows disc changeover in seconds



VARILEX® Specifications

| | | |
|--------------------|---|---|
| Item ID: | 65030U |  |
| Motor Power | 15 Amp (1710 Watts); 110 Volt/50/60Hz (Also available: 230 Volt / 50 Hz) | |
| Speed Control Dial | Infinitely adjustable from 2400 to 8900 RPM | |
| Wheel Diameter | 4" to 7" | |
| Spindle Thread | 5/8"-11 UNC |  |
| Arbor Size | 7/8" | |
| Weight | 6.2 lbs. | |

Use with various discs and safety guards

Available with optional 7" safety guard for use with various-size grinding discs from 4" to 7" diameter (typical disc diameters are 4", 4-1/2", 5", 6" and 7").

The VARILEX® is not designed for continuous use at low speed for polishing paint in the automotive trade.

FIX Hook & Loop Kits for VARILEX® System

Two versatile FIX Hook & Loop System kits for polishing up to a #8 mirror finish!

- Changeover in seconds between abrasives
- Wide selection available

See pages 98-101 for kits & abrasive consumables.



5/8"-11 EASY-LOCK SPEED NUT Clamping System



Using the EASY-LOCK SPEED NUT, you can change the abrasive disc on the VARILEX® in a matter of seconds – without tools!

Easy hand tightening eliminates the need for wrenches and expensive 5/8"-11 hubs. **Item ID: 65008-1**

↓ TIPS & TRICKS



Polish stainless steel to a mirror finish with the VARILEX® I

(1) Initial grinding (remove scratches and roller scale, level welds) with TZ Pyramid disc D45 (grit 400) or D65 (grit 280). Finish with TZ Pyramid disc D30 (grit 600) and D16 (grit 1200). (→page 99)

(2) Main polish with SuperPolish disc and white polishing compound, then with blue polishing compound. Important: Use a separate disc for each compound grit.

(3) Mirror finish with SuperPolish disc and pink polishing cream. (→page 99)

Flexible Shaft Ordering Information

| Item | Item ID: |
|--|----------|
| Flexible shaft with 5/16" steel wire and 5/8" thread | 10015 |
| Separate 1/8" collet for flexible shaft | 10011A |
| Separate 1/4" collet for flexible shaft | 10011B |
| Machine holder (powder-coated steel) incl. clamping screw for VARILEX® | 10008 |

PLANTEX[®] Flap Discs

INDUSTRY FIRST! NEW ECO-FRIENDLY PLANTEX DISCS WITH INDUSTRIAL PROTECTED HEMP BACKING

Renewable Resource
Environmentally Sustainable

More Impact Resistant
vs. Fiberglass

Plant-Based Hemp
Backing Plate

Built-in Easy
Spin-on 5/8" x 11

Absorbs Heat & Sound

Trimmable for
Extended Life



SUPERIOR PERFORMANCE *Made in Germany*

- Internationally Patented Unique Formula: Optimal grinding, blending, & finishing
- Eco-Friendly: 50% less energy is used in production of PLANTEX Discs
- 100% Usable flaps, down to the backing

COMPETITIVELY PRICED



NEW Flap Disc

PLANTEX[®]
RAZORFLAP



A next-generation of ceramic grain that has a cut rate of a fiber disc combined with the durability of a flap disc. (Type 29)

| Item ID: | Diameter | Arbor | Grit | QTY |
|----------|----------|-------------------|------|--------|
| 82210 | 4-1/2" | 5/8" x 11 Spin On | 36 | 5 Pack |
| 82211 | 5" | | 36 | |

High performance, patented grain & design that excels on stainless steel, carbon steel, & heat sensitive alloys providing extra long-life. (Type 29)

| Item ID: | Diameter | Arbor | Grit | QTY |
|----------|----------|-------------------|------------------|---------|
| 93520 | 4-1/2" | 5/8" x 11 Spin On | Multigrain 40/60 | 10 Pack |
| 93519 | 4-1/2" | | 80 | |
| 93521 | 5" | | Multigrain 40/60 | |
| 93523 | 5" | | 80 | |
| 93516 | 6" | 7/8" | Multigrain 40/60 | |
| 93517 | 6" | 7/8" | 80 | |

PLANTEX[®]
SunFire[®]
Ceramic



A premium zirconia grain for use on carbon and stainless steel. High metal removal rates and long life. (Type 29)

PLANTEX[®]
SpitFire
Premium Zirconia



| Item ID: | Diameter | Arbor | Grit | QTY |
|----------|----------|-------------------|------|---------|
| 93564 | 4-1/2" | 5/8" x 11 Spin On | 40 | 10 Pack |
| 93566 | 4-1/2" | | 60 | |
| 93568 | 4-1/2" | | 80 | |
| 93569 | 4-1/2" | | 120 | |
| 93574 | 5" | | 40 | |
| 93576 | 5" | | 60 | |
| 93578 | 5" | | 80 | |
| 93579 | 5" | | 120 | |
| 93499 | 6" | 7/8" | 40 | |
| 93500 | 6" | | 60 | |
| 93501 | 6" | | 80 | |
| 93502 | 6" | | 120 | |

A zirconia grain for use on carbon steel & stainless steel, overhang excels for corners & tight areas, for fast cut & long-life, an excellent value. (Type 29)

| Item ID: | Diameter | Arbor | Grit | QTY |
|----------|----------|-------------------|------------------|---------|
| 93485 | 4-1/2" | 5/8" x 11 Spin On | Multigrain 40/60 | 10 Pack |
| 93486 | 4-1/2" | | 80 | |
| 93488 | 5" | | Multigrain 40/60 | |
| 93489 | 5" | | 80 | |

PLANTEX[®]
Weld-Ex
Zirconia



A special grain & formula to grind & blend aluminum and other non-ferrous materials while minimizing loading and providing long-life. (Type 29)

PLANTEX[®]
Aluminum



| Item ID: | Diameter | Arbor | Grit | QTY |
|----------|----------|-------------------|------|---------|
| 93854 | 4-1/2" | 5/8" x 11 Spin On | 40 | 10 Pack |
| 93856 | 4-1/2" | | 60 | |
| 93858 | 4-1/2" | | 80 | |
| 93859 | 4-1/2" | | 120 | |
| 93864 | 5" | | 40 | |
| 93866 | 5" | | 60 | |
| 93868 | 5" | | 80 | |
| 93869 | 5" | | 120 | |



Kangaroo ALU-FIX[®] OIL
Spray on aluminum workpiece to improve the removal rate and increase abrasive life.

- 1-pint spray bottle - Item ID: 40010
- 1.3 gal. canister and spray bottle Item ID: 40010K

FIX HOOK & LOOP SYSTEM

Highly flexible backing disc for high-quality finishes. Ideal for surface conditioning and polishing up to a mirror finish.

The FIX Hook & Loop system takes advantage of a flexible backing pad and allows a disc to be changed in seconds without tools.

The FIX Hook & Loop system is a good fit wherever disc flexibility and frequent changeover are required. It will save time in industrial metalworking applications such as car body shops and repair shops.

The system requires a speed-controlled angle grinder, such as the VARILEX®. A wide range of abrasives are available for all steps – from rough grinding up to a mirror finish.

The FIX Hook & Loop's "green" backing disc is made of natural materials. The flexibility of the abrasives allows you to achieve results similar to stationary grinding machines.

The FIX family of abrasives must be used with the FIX original backing pads.

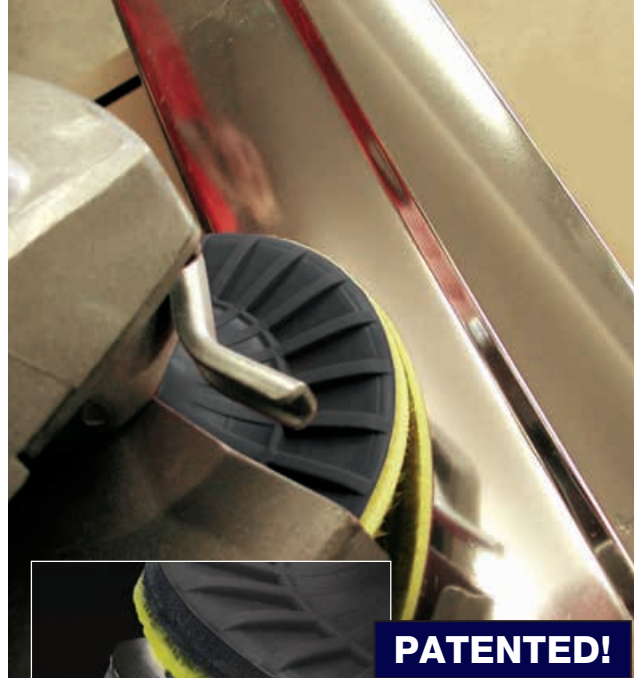

PATENTED!



The FIX Hook & Loop system is an essential surface finishing and polishing system for all sheet metal applications.

FIX Hook & Loop System Kits

FIX Starter Kit

This kit includes a range of FIX Hook & Loop components, as well as a VARILEX® WSF 1802 Angle Grinder. **Item ID: 80050U**

- 1 VARILEX® WSF 1802 HT, 110V, 5/8" spindle
- 1 Carrying case
- 1 FIX backing pad - 4-7/16"
- 1 Wheel guard for discs up to 5"
- 3 FIX fleece discs 4-1/2" (1 each - coarse, medium, fine)
- 1 EASY-LOCK SPEED NUT
- 2 FIX FLEECE TOP 4-1/2" (1 each - grit 80, 180)
- 2 FIX flap discs 4-1/2" (1 each - grit 40, 60)
- 2 FIX SuperPolish discs 4-1/2"
- 1 FIX clean 4-1/2"
- 1 PTX Brightex® Softclean Powder scatter can
- 4 FIX Zirconium discs 4-1/2" (1 each - grit 40 - 120)
- 2 Mini-polishing pastes, white and blue

FIX Test Kit

This kit contains all the FIX Hook & Loop System components to go from rough grinding up to a mirror finish. **Item ID: 80051U**

- 1 Carrying case
- 1 FIX backing pad
- 8 FIX Zirconium discs 4-1/2" (2 each - 40, 60, 80, 120 grit)
- 10 FIX TZ Pyramid discs 4-1/2" (2 each - 280, 400, 600, 1200, 2000 grit)
- 8 FIX Surface Conditioning discs 4-1/2" (2 each - coarse, medium, fine, superfine)
- 6 FIX SuperPolish discs 4-1/2"
- 2 Mini-polishing pastes, white and blue
- 1 PTX polishing cream pink
- 1 PTX Brightex® Softclean Powder scatter can
- 2 PTX microfiber cloths
- 1 Sample size PTX Poly Protection
- 1 Sample size PTX Brilliance Clean



↓ TIPS & TRICKS

Perfect mirror finish on stainless steel and nonferrous metals

The new TZ Pyramid and SuperPolish discs for the FIX Hook & Loop system can be used with an angle grinder to create perfectly polished finishes on stainless steel and nonferrous metals.

Pre-grinding to remove scratches and level welds using TZ Pyramid discs with grit D30.

Fine grinding using TZ Pyramid discs with grit D16.

These two stages prepare the surface for polishing. TZ Pyramid is an aggressive abrasive, so there is no need to slowly increase the grit fineness. Use only contact pressure to grind – the weight of the grinder is generally sufficient.

Pre-polish with SuperPolish disc and white polishing compound.

Main polish with SuperPolish disc and blue polishing compound.

Perfect mirror finish with SuperPolish disc and pink cream.

Use a separate SuperPolish disc for each step – the different compound grits must not be mixed. Remove compound and cream residues after each stage using PTX Brightex® Softclean Powder and a microfiber cloth.

Abrasives for the FIX Hook & Loop System

The FIX family of abrasives must be used with the FIX original backing disc.



FIX Backing Pads with Centering Pin

For use with the FIX Zirconium, FIX TZ and FIX SuperPolish discs. The backing disc is made of special elastic with a centering pin for perfect alignment.

Without Foam:

Diameter: 4.5" with 5/8"-11 thread – Item ID: 80115U

Diameter: 6" with 5/8"-11 thread – Item ID: 80150U



With 1/4" PUR Foam absorptive coating:

Diameter: 4.5", 5/8"-11 thread – Item ID: 80115UF

Diameter: 6", 5/8"-11 thread – Item ID: 80150UF

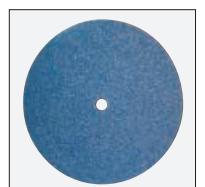

FIX Zirconium Disc

Abrasive disc with Hook & Loop fastening and an outstanding grinding capacity. Ideal for body shops and car workshops.

FIX Zirconium Disc Ordering Information

| Item ID: | Diameter | Grit | Quantity |
|----------|----------|------|----------|
| 80904 | 4 1/2" | 40 | 50 pack |
| 80906 | | 60 | |
| 80908 | | 80 | |
| 80909 | | 120 | |
| 80914 | 6" | 40 | 50 pack |
| 80916 | | 60 | |
| 80918 | | 80 | |
| 80919 | | 120 | |



FIX Fleece (Nonwoven) Disc

Versatile disc for fine surface conditioning and pre-polishing.

FIX Fleece (Nonwoven) Disc Ordering Information

| Item ID: | Diameter | Grit | Quantity |
|----------|----------|------------------|----------|
| 80615 | 4 1/2" | coarse (brown) | 10 pack |
| 80616 | | medium (red) | |
| 80617 | | fine (blue) | |
| 80618 | | superfine (grey) | |
| 80650 | 6" | coarse (brown) | 10 pack |
| 80651 | | medium (red) | |
| 80652 | | fine (blue) | |
| 80653 | | superfine (grey) | |



FIX (Nonwoven) Disc

The new FIX-Klett disc is a superfine soft nylon-fleece material for pre-polishing aluminum or other soft, nonferrous materials to a mirror finish.

Diameter: 4-1/2"; Superfine grit, Item ID: 80680 (10 pack)

Diameter: 6"; Superfine grit, Item ID: 80690 (10 pack)



FIX TZ Pyramid Disc

Abrasive fabric with pyramid-shaped grit structure for high material removal while producing a very fine finish. FIX TZ Pyramid discs reduce the amount of work required compared to grinding belt and

fleece sleeves. Ideal for pre-polishing for mirror finishes and for removing scratches and spot welds. An additional coating dramatically reduces the grinding temperature and protects the Hook & Loop components and workpiece.

FIX TZ Disc Ordering Information

| Item ID: | Diameter | Grit/Equivalent | Quantity |
|----------|----------|-----------------|----------|
| 80932 | 4 1/2" | D100/220 | 10 pack |
| 80932 | | D65/280 | |
| 81214 | | D45/400 | |
| 80960 | | D30/600 | |
| 80970 | | D16/1200 | |
| 80980 | | D06/2000 | |
| 80985 | 6" | D65/280 | 10 pack |
| 80986 | | D45/400 | |
| 80987 | | D30/600 | |
| 80988 | | D15/1200 | |
| 80989 | | D06/2000 | |

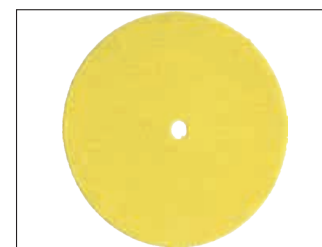

FIX SuperPolish Disc

SuperPolish is a special needle fleece that produces a perfect, brilliant mirror finish on stainless steel and nonferrous metals. Use with our polishing compounds (white and blue) and pink

cream to avoid smears and shadows. SuperPolish is absorbent, does not smear and saves time.

Diameter: 4-1/2"; Thickness: 1/4", Item ID: 80715N (10 pack)

Diameter: 6"; Thickness: 1/4", Item ID: 80750N (10 pack)



FIX SuperPolish Felt Disc

Special merino wool felt that produces a perfect, brilliant mirror finish on stainless steel and nonferrous metals. Use with our polishing compounds (white and blue) and pink cream to avoid smears and shadows.

Diameter: 4-1/2"; Thickness: 1/4", Item ID: 80715 (10 pack)

Diameter: 6"; Thickness: 1/4", Item ID: 80750 (10 pack)

When polishing with **FIX SuperPolish Discs**, use a separate SuperPolish disc for each compound and cream. The different compound grits must not be mixed. Remove compound and cream residues from the workpiece after each stage using PTX Brightex® Softclean Powder and a microfiber cloth.

POLY-MAGIC UNITIZED WHEEL

Dry polish stainless steel in corners up to a mirror finish!

The POLY-MAGIC-WHEEL is designed for finishing and dry polishing in corners, producing up to a perfect mirror finish in just two steps. These discs are composed of highly compressed fleece material, made by compressing single flaps that are then impregnated with foam for greater strength. This special process allows considerably more abrasive material to be used than on conventionally wound "unitized wheels and discs."

The POLY-MAGIC-WHEEL is ideal for grinding and polishing bead and corner welds. It may only be used frontally.

Ideal for speed-controlled angle grinders.

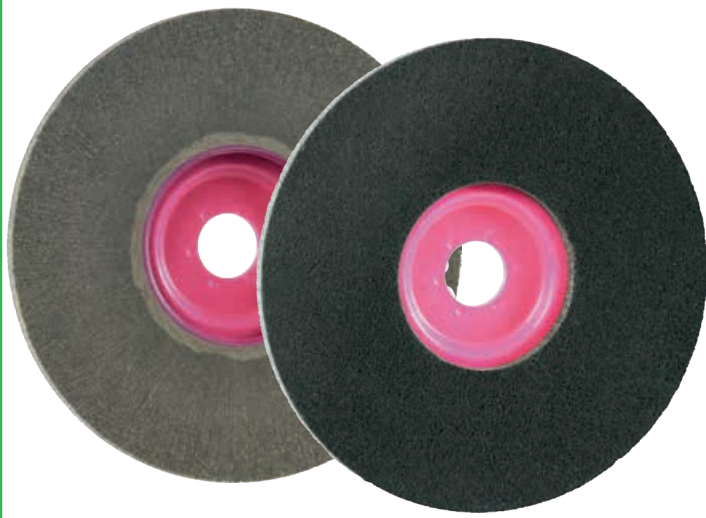

Polishing corner welds with the POLY-MAGIC-WHEEL

Obtaining good polish quality when finishing corner welds is difficult, especially for the fabrication of railings. The POLY-MAGIC-WHEEL was designed to help you more easily produce a truly perfect finish in these applications. This highly compacted fleece disc was designed specifically for grinding and polishing bead and corner welds.

Carry out the initial grinding and leveling of welds with the red disc, grit A (80 grit).

Then polish to a mirror finish using the POLY-MAGIC gray disc, grit B (900 grit). These discs are very aggressive and improve productivity. No polishing compounds or creams are required for polishing with the POLY-MAGIC-WHEEL (dry polish).

POLY-MAGIC-WHEEL

Dimensions 6 1/2" dia. x 7/8" arbor

Max. Speed 5000 RPM

Ideal Speed 3000 to 4000 RPM

A/80 (light gray): for initial grinding and leveling welds. (Item ID: 96720, 5 pk.)

B/900 (dark gray): for polishing to a perfect mirror finish. (Item ID: 96721, 5 pk.)

Mirror finish in 2 steps:



1 POLY-MAGIC-WHEEL A (80 grit)



2 POLY-MAGIC-WHEEL B (900 grit)



MAGNUM® TOPMIX

Increased material removal, longer service life.

The MAGNUM® TOPMIX was developed to increase material removal during finishing while also improving service life. The 80 combination grit is much more aggressive than our MAGNUM® FLEECE TOP 80 grit (see next page). Individual flaps with foamed and compressed fleece offer a much higher removal capacity, making it ideal for removing spot welds and deep scratches on stainless steel, steel and nonferrous metals. The coordinated fleece combination additionally ensures that a good finish is achieved. The MAGNUM® TOPMIX also offers excellent service life, making deburring and cleaning of cast parts and welds a breeze.

Ideal for speed-controlled angle grinders.

MAGNUM® TOPMIX

Dimensions 5 dia. x 7/8" arbor

Max. Speed 6000 RPM

Ideal Speed 2000 to 4500 RPM

Grits **40/80** (Item ID: 96705, 5 pk.)

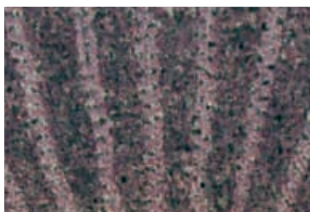

MAGNUM® FLEECE TOP

Made of foamed, compressed grit, interspersed nonwoven fleece.

The MAGNUM® FLEECE TOP is a versatile fleece disc for surface conditioning, fine finishing and polishing, offering up to 8x the service life of traditional fleece and surface conditioning discs. The FLEECE TOP is an ideal disc for metalworking that requires fine grinding and pre-polishing to a uniform clean finish. It is effective at descaling and removing oxidation, scratches, rust, burrs and paint. It replaces a wire brush, abrasive paper and grinding rubbers and is self cleaning, with a special mixture that prevents glazing and loading. The foamed fleece ring is approx. 5/8" thick. This highly compressed quantity of fleece material ensures an extra-long service life.

Ideal for speed-controlled angle grinders.

MAGNUM® FLEECE TOP

Dimensions 4 1/2" dia. x 7/8" arbor

Max. Speed 8000 RPM

Ideal Speed 2000 to 4500 RPM

Grits
80 (Item ID: 96710, 5 pk.)
180 (Item ID: 96711, 5 pk.)
280 (Item ID: 96712, 5 pk.)
400 (Item ID: 96713, 5 pk.)
600 (Item ID: 96714, 5 pk.)
900 (Item ID: 96715, 5 pk.)

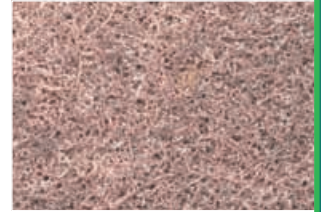
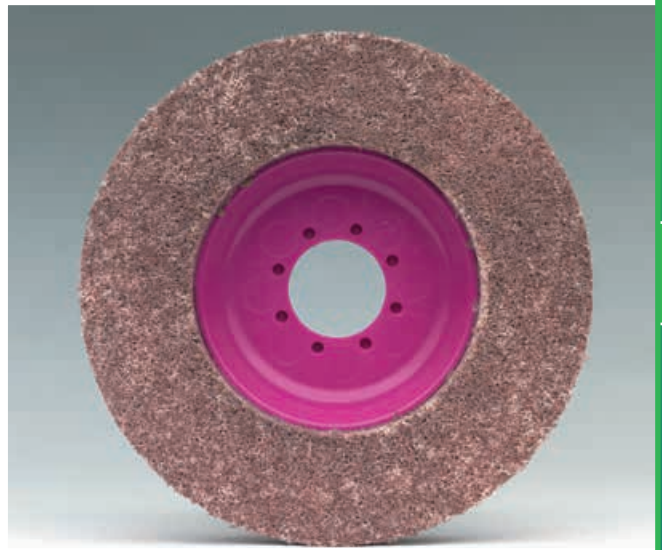

Scan to
Learn More



MAGNUM® CLEAN

For pore-deep cleaning of metals
(sandblasting effect).

MAGNUM CLEAN® is a flexible cleaning disc for the pore-deep cleaning of metals. This flexible coarse fleece disc is interspersed with silicon carbide grit and cleans without harming the base material. The disc itself is iron free, which means that there is no risk of corrosion. The coarse fleece material will not glaze or load, even if exposed to heavy contamination. MAGNUM CLEAN® is the ideal cleaning disc for pore-deep removal of paint, rust, scale and oil smears, as well as for cleaning and exposing without material removal. It is ideal for use in body shops (cleans thin sheet metal with no material removal) and in the automotive industry, and it is also suitable for undersealing, renovating, painting and building work. MAGNUM CLEAN® is particularly good for removing paint and other coatings on wood, stone and metal (including window frames, doors and frames, furniture, house facades, graffiti, railings, fences, supports and machines).

Ideal for speed-controlled angle grinders.

MAGNUM® CLEAN

Dimensions 5 dia. x 7/8" arbor

Max. Speed 5000 RPM

Ideal Speed 2000 to 4500 RPM

Grits **Medium** (Item ID: 96700, 5 pk.)

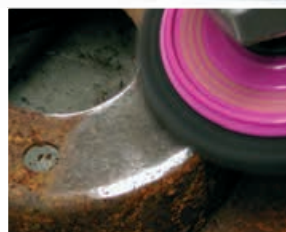

PIPE-MAX

Pipe Belt Grinder

Combination pipe belt sander and grinder for diameters up to 14"

Follow contours to grind and polish pipes and handrails up to a high-gloss finish

- Grinds weld seams on flat surfaces – leaves no edges
- Belt wraps around pipe and requires only a few steps to polish entire circumference
- Powerful 15 Amp motor and variable-speed control from 950 to 3500 RPM
- Quick and easy changing of sanding belts
- Ideal for stainless steel, aluminum and high-quality metals
- Patented damping concept with gas pressure damper enables maximum "pipe enclosure" with minimal effort.
- Tachogenerator provides constant speed, even under load



The new contour concept with the elastic return roller allows the grinding and polishing belts to conform around the external diameter of the pipes with light, uniform pressure.



1 Gas pressure cylinder allows belt to conform to contour of pipe with proper pressure.



2 Additional handle for comfortable, overhead working.



3 The drive roller with the rubber belt ensures that the grinding belts will not slip.

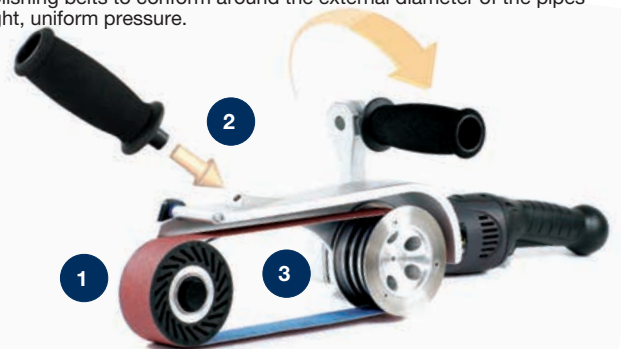

| PIPE-MAX Specifications | |
|-------------------------|------------------------|
| Item ID: | 38502A |
| Belt Size | 30.7" L x 1.5" W* |
| Power | 15 Amp (1710 W) / 110V |
| Pipe ø Max. | 14" |
| Weight | 11.25 lbs. |



The soft grinding roller made of PUR material also allows comfortable longitudinal grinding of flat surfaces, for example to remove spot welds or eliminate deep scratches.

230V models also available

| Standard Equipment | |
|---|------------------------------------|
| 1 PIPE-MAX basic machine, 110V | 2 PIPE-MAX SC-fleece belts, medium |
| 1 QUICK-LOCK cable, 13 feet | 2 PIPE-MAX SC-fleece belts, fine |
| 1 additional handgrip | 1 spare belt - Item ID: 42006 |
| PIPEMAX grinding belts, 2 each grits 40, 60, 80 and 120 | |

The King-Boa, Pipe-Max & Gladius all use the same abrasives. To see the abrasives offered see page 105

NEW
Battery Powered PIPE-MAX
Same reliable power - No restrictions
 Item ID: 38301U (Battery and Charger included)

Item ID: 50463 (Battery)
 Item ID: 50474U (Charger)



Scan to Learn More



KING-BOA™

Blend, finish and polish up to a mirror finish. For use on all metal handrails, railing, tubing and pipe

- Fast, efficient and uniform blending and finishing on round handrails and pipe up to 5" dia.
- Wraps around the workpiece 270° - rotate slightly for 360° all-around finish.
- Increase productivity and reduce fatigue – ergonomic design and optimal belt tension requires minimal user pressure.
- Planetary gearbox engineered for 50% more torque
- Battery powered version now available



IDEAL FOR USE IN NARROW SPACES

180° adjustable top handle and compact head fit in narrow areas between walls and floors



Item ID: 38810U



NEW

Battery Powered PIPE-MAX

Same reliable power - No restrictions

Item ID: 38821U (Battery and Charger included)

Item ID: 50463 (Battery)

Item ID: 50474U (Charger)



180° adjustable handle for working in tight spaces (closed handrails and small-diameter pipe)

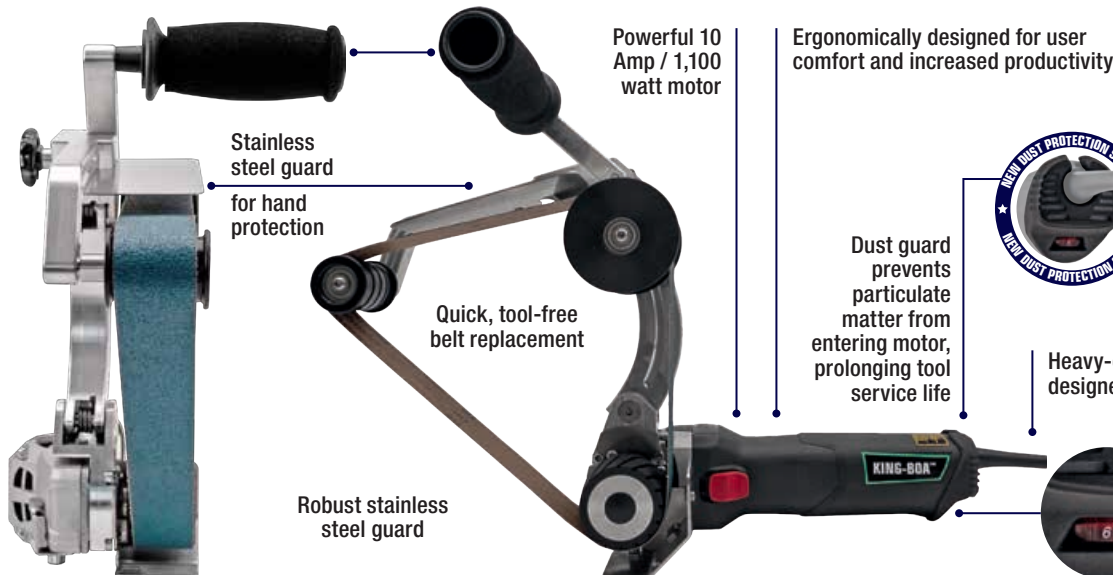

HighTorque HT

Powerful, high-torque planetary gearbox

30% higher power reserves with up to 50% more torque vs. the competition

Electronic overload protection and soft start
Made in Germany



See KING-BOA Abrasives & Specifications on Next Page

KING-BOA™ SPECIFICATIONS

KING-BOA™ Specifications

| | |
|-------------------|--|
| Item ID: | 38810U |
| Power | 10 Amp / 1,100 watt |
| Belt Speed | 800-3000 RPM |
| Belt Size | 30.7" x 1.5" (780mm x 40mm) |
| Weight | 9 lbs. |
| Capacity | 3/4" to 3-1/4" (Ideal Pipe Dia.) 5" (Maximum Pipe Dia.) |

230V models also available

Standard Equipment

- 1 KING-BOA Railing Belt Sander
- 1 Motor Protection Dust Guard
- 6 Zirconium Belts (2 ea. 60, 80, & 120 Grit)
- 2 SC Fleece Belts (1 medium & 1 fine)



Gladius® Multifunctional Grinder

Ideal for hard-to-reach areas such as corners, angles and tight spaces.

- Grind, deburr, blend and polish ferrous and nonferrous metals, wood and plastic
- Tachogenerator provides constant speed, even under load
- Fast changing of belts
- Abrasive guide extension arm consists of a new special alloy for significantly reduced grinding temperatures



Gladius® Specifications

| | |
|------------------|-------------------|
| Item ID: | 38901U |
| Belt Size | 30.7" L x 1.5" W* |
| Power | 15 Amp / 110V |
| Speed | 820 - 3800 RPM |
| Weight | 10 lbs. |



Scan to
Learn More

Standard Equipment

- 1 GLADIUS®
- 1 pre-installed fine dust protective cap
- 4 premium zirconia belts (2 each: 60 & 80 grit)
- 3 replacement rubber rings (Item ID: 42006)

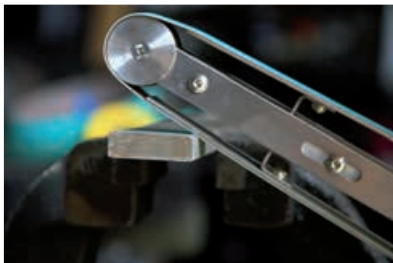

Abrasives & Accessories for PIPE-MAX, KING-BOA & GLADIUS

Abrasive Grinding Belts

10 Belts per package

| Grit | Item ID: |
|------|----------|
| 24 | 38523 |
| 40 | 38524 |
| 50 | 38525 |
| 60 | 38526 |
| 80 | 38528 |
| 120 | 38529 |



Ceramic Grinding Belts

10 Belts per package

| Grit | Item ID: |
|------|----------|
| 24 | 38124 |
| 36 | 38136 |
| 50 | 38150 |
| 60 | 38160 |
| 80 | 38180 |
| 100 | 38100 |

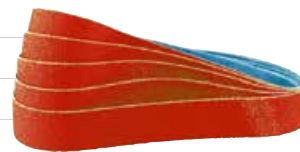

Surface Conditioning Fleece Belts

4 Belts per package

| Grit | Item ID: |
|------------------|----------|
| Coarse (brown) | 38531 |
| Medium (red) | 38532 |
| Fine (blue) | 38533 |
| Superfine (grey) | 38534 |



TZ Pyramid Belts

10 Belts per package

| Grit | Item ID: |
|----------|----------|
| D100/220 | 38544 |
| D65/280 | 38583 |
| D45/400 | 38546 |
| D30/600 | 38585 |
| D16/1200 | 38548 |

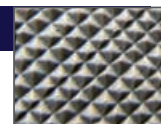

Polishing Compounds

PTX Pre-grinding & Polishing Compound

Essential for polishing all metals.

PTX WHITE pre-polishing (23 oz.) – **Item ID: 40013**

PTX BLUE finishing (23 oz.) – **Item ID: 40014**

PTX WHITE and BLUE min (approx 4.2 oz. ea.) – **Item ID: 40009**

PTX Polishing Cream, Pink

High reflective finishing – perfect mirror finish on stainless steel and nonferrous metals. Use with SuperPolish Belt.

Miniature tube (2 oz.) – **Item ID: 40015T**

Can (2.2 lbs.) – **Item ID: 40015**



SuperPolish Belt

4 Belts per package

Item ID: 38850



PTX Brightex® Softclean Powder (non-caustic) Remove cream and compound residues.

Microfiber cloths, 25 qty. (13" x 14") – **Item ID: 40031**

Aluminum scatter container w/ Brightex® (approx. 7oz.) – **Item ID: 40029**

Bag (2.2 lbs.) – **Item ID: 40028**

Scan QR Code for all polishing and maintenance products



INOX-Protect (hard sealant) Protects finished and polished metal surfaces (stainless steel, steel, aluminum, brass, copper, etc.) with a clear, dry adhesive film. Removes fingerprints and other dirt.

Canister (w/ spray bottle), 1.3 gal. – **Item ID: 40041** **Spray bottle, 17 oz.** **Item ID: 40040**



Brilliance-Clean For streak- and residue-free cleaning of all surfaces, including stainless steel, steel, aluminum, brass and copper. Brilliance-Clean is not harmful to plastics, wood or coated surfaces. Remove fingerprints, dust, compound residue, minor oil and grease marks and adhesive residue. Evaporates quickly without leaving residue.

Canister (w/ spray bottle), 1.3 gal. – **Item ID: 40051** **Spray bottle, 17 oz.** **Item ID: 40050**



POLY Protection (oil film) For cleaning and preserving finished and polished stainless steel and nonferrous metal surfaces. Protects against shadows and finger and water marks for a long time. Spray on and rub off with a microfiber cloth. Produces a darker effect on finished surfaces.

Canister (w/ spray bottle), 1.3 gal. **Item ID: 40012** **Spray bottle, 17 oz.** **No. 40011**

Speak to one of our technical specialists for assistance with your metal finishing applications

ROLEI® BE 5 Sheet Metal Deburring Machine – 2 Speeds

Double-sided deburring of sheet metal up to 0.2" thick can be achieved in a single operation with no additional treatment. The machine's flap wheels can be easily adjusted as they wear. One set of wheels lasts for approximately 6500 feet of stainless steel sheet. Supplied standard with two 80 grit flap wheels, the ROLEI® BE 5 can be used with other optional grits to suit the facet width and materials of your particular application.



Scan to Learn More

Features two-speed operation:

- Speed 1: fine deburring, 600 RPM
- Speed 2: standard deburring, 1200 RPM

Optional accessories:

- Spare flap wheels (40, 60, 80, and 120 grit)
- Machine stand, made from strong steel
- Port for industrial dust extractor (Item ID: 30330)

ROLEI® BE 5 Specifications

| | |
|------------|---|
| Item ID: | 30310A (220 Volt) 30310 (380 Volt) |
| Motor | 220V 3-phase, 2 speeds, .2 KW, 0.9 Amp 380V 3-phase, 2 speeds, .2 KW, 0.45 Amp |
| Dimensions | 19.7" x 12.8" x 7.9" |
| Weight | 64 lbs |
| Options | Machine stand, dust extractor connection port, teflon tape |

ROLEI® BE 5 Flap Wheels

| Item ID: | Grit | Qty. |
|----------|------|------------------|
| 37040 | 40 | 2 discs per pack |
| 37060 | 60 | 2 discs per pack |
| 37080 | 80 | 2 discs per pack |
| 37120 | 120 | 2 discs per pack |

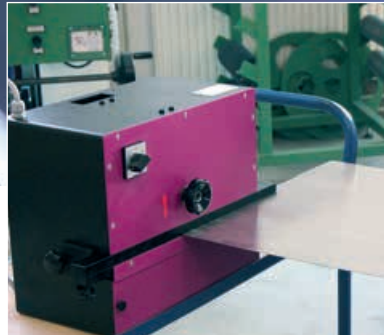
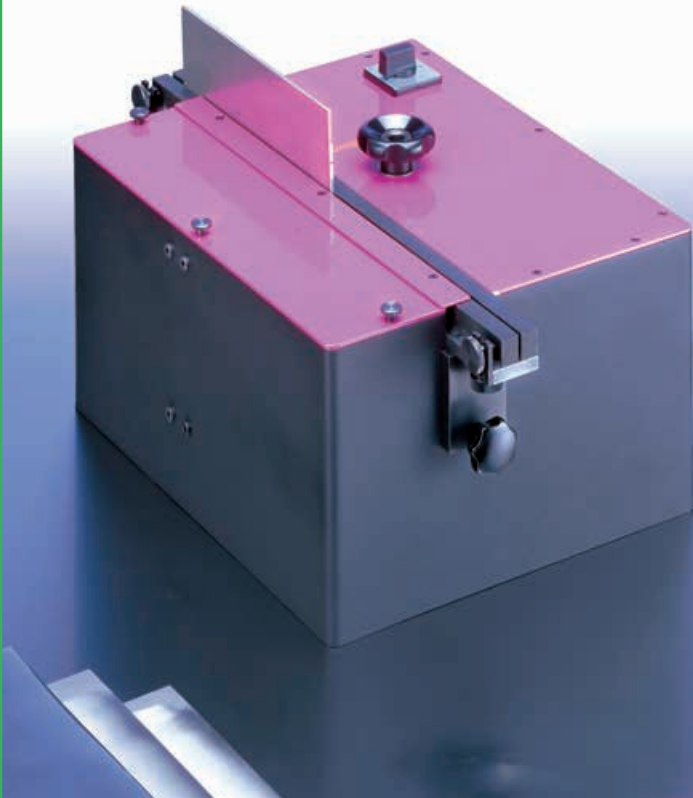

Can also be used on its side with roller tables for large thin sheets.

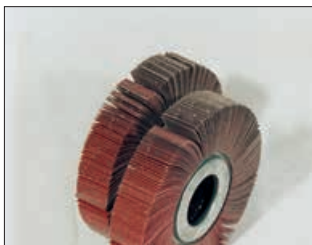
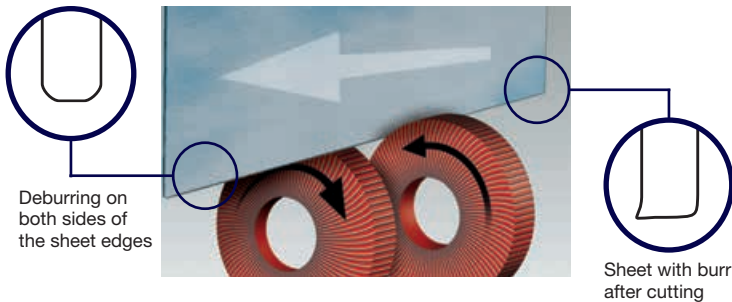

Spare flap wheels for sheet metal deburring machine BE 5
Grit 40, 60, 80, 120



Machine stand - Item ID: 30320
Strong steel machine stand with black powder coating



Dust extraction port (end and bottom views shown above)
Item ID: 30330



Teflon protective tape – self-adhesive (2 required)
Item ID: 30341 (27.5" L x 3/4" W)
For extension rail to protect from scratching the workpiece

ROLEI® EF 115 Hand-held Deburring and Faceting Machine

This handy deburring machine is designed for awkward, heavy parts, such as machine tables, frame constructions or large sheets of metal. Easy to handle, with good edge control. The EF 115 is also ideal for chamfering welds. Fixed beveling angle of 45°, infinitely adjustable facet width from 0" to 3/8".



The ROLEI® EF 115 can deburr and facet large, heavy parts with ease. The precise edge control guarantees clean bevels at an angle of 45°.



ROLEI® EF 115 Flap Discs

| Item ID: | Grit | Quantity |
|----------|------|-------------------|
| 21050A | 50 | 10 discs per pack |
| 21060A | 60 | 10 discs per pack |
| 21080A | 80 | 10 discs per pack |
| 21120A | 120 | 10 discs per pack |

ROLEI® EF 115 Specifications

| | |
|-----------------|---|
| Item ID: | 30116 |
| Universal Motor | 15 Amp (1710 W) 110/60 Hz (230V / 50 Hz, 1600 W also available) |
| Speed | Infinitely adjustable from 2000 to 7600 RPM |
| Weight | 9 lbs |
| Options | Sliding Guide rail, plastic (Item ID: 30117, 2-piece set) |



Scan to
Learn More



ROLEI® PEF 500

ROLEI® PEF 500 Specifications

| | |
|------------|--|
| Item ID: | 30201 (220 Volt) 30200 (380 Volt) |
| Motor | 220V single-phase or 380V 3-phase |
| Dimensions | 20" x 14" x 14" |
| Weight | 88 lbs. |
| Options | Machine stand, extraction port for dust extractor connection |

Supplied as standard with 80 grit (36080) disc. Optional discs include 60 grit (36060) and 120 grit (36120)



ROLEI® EF 165

ROLEI® EF 165 Specifications

| | |
|---------------|---|
| Item ID: | 30101 (220 Volt) 30100 (380 Volt) |
| Motor | 220V single-phase or 380V 3-phase |
| Dimensions | 14" x 13" x 12" |
| Support Table | 5" x 13" |
| Weight | 40 lbs. |
| Options | Table extension, machine stand, extraction port for dust extractor connection |

Supplied as standard with 80 grit (36080) disc. Optional discs include 60 grit (36060) and 120 grit (36120)

Multipurpose Beveling Machines

Bevel, deburr and chamfer edges of steel plate faster and cleaner than angle grinders.

- Bevel 30°, 45°, 2.5mm or 1.6mm radius on steel, stainless, nonferrous metals, brass and plastics
- Deburr and chamfer; straighten edges, internal and external radii; and countersink holes from 7/8" dia.
- Fine adjustment feature for slight chamfers when deburring for the preparation of weld seams
- Ideal for: **Boiler and process plant construction** (prepare weld seams on heat exchangers); **Mechanical engineering** (deburr machine parts, chamfer edges to protect against paint peeling and create visible edges); **Sheet metal** (deburr cut edges); **Moldmaking** (straighten edges, internal and external radii and countersink holes from 7/8" dia.)



Three Milling Options

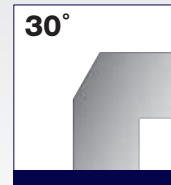

Milling cutter 30°, Chamfer 0 - 1/4"

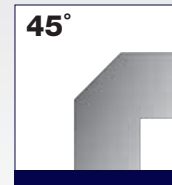

Milling cutter 45°, Chamfer 0 - 1/4"

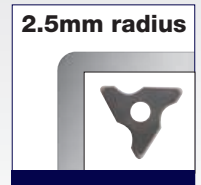

Milling cutter 2.5mm radius (0.098")



Scan to Learn More



0-1/4" beveling width

Three Models:
EKF 300.3 - 30°
EKF 450.3 - 45°
EKF 452.3 - 2.5R

Also available:
1.6mm / 0.063"
cutting inserts (SHM 201).
Contact us for details.



Fine adjustment
Precise control of chamfer when deburring for weld seam preparation

0-9/16" (15mm) beveling width

Two Models:
EKF 630 - 30°
EKF 645 - 45°



| Specifications | Model EKF 300.3* | Model EKF 450.3* | Model EKF 452.3* | Model EKF 630 | Model EKF 645 |
|--|---|------------------|------------------|--|---------------|
| Beveling Angle | 30° | 45° | 2.5mm (0.098") | 30° | 45° |
| Bevel Width (max.)*** | 1/4" | 1/4" | 1/4" | 9/16" | 9/16" |
| Motor Power | 13.5 Amp/110V** | | | 19.1 Amp/110V** | |
| Milling Head | ZFR 300.3 | ZFR 450.3 | ZFR 452.3 | ZFR 630 | ZFR 645 |
| Cutting Speed | 3000 SFPM | | | 1200-1500 SFPM | |
| Cutting Inserts Qty on milling head | 3 inserts / 3 sided △ | | | 10 inserts / 4 sided □ | |
| Available Inserts (Sold as pack of 10) | SHM200; SHM 200-E (for stainless steel); SHM 202 (2.5mm radius); SHM 201 (1.6mm radius) | | | SHM 900 SHM 900-E (for stainless steel) | |
| Dimensions | 12 ¹ / ₂ " L x 5 ¹ / ₂ " W x 11 ⁵ / ₈ " H | | | 15 ³ / ₄ " L x 13 ¹³ / ₁₆ " W x 11 ¹³ / ₁₆ " H | |
| Weight | 10.5 lbs. | | | 22.5 lbs. | |

*Heads are interchangeable **220 V / 50 Hz also available. ***Max bevel width may require several passes, depending on material hardness

SKF Beveling Machine for Plates and Pipes

Fast, easy preparation of weld seams and bevels on plate or pipe.

- Bevel 15° to 60° angles and land width up to 3/4" on steel, stainless steel, aluminum and nonferrous metal plates and pipe
- Work on welding angles and weld preparation on pipes/tubes with a minimum OD of 6-1/4" (160mm) with built-in pipe roller guide; ideal for beveling pipe 6-1/4" OD and larger
- Robust design, single operator control and easy handling
- Anti-vibration system for operator comfort



Standard equipment includes one milling head, 10 sintered carbide reversible cutting inserts, tools for assembly, built-in pipe roller guide, steel carrying case and user's manual. Please see our Price List for available accessories.

Cutting Inserts - Sold as pack of 20
 Item ID: **SHM 800 N**: For beveling carbon and stainless steel

SKF Portable Beveler Specifications

| | |
|-----------------|------------------------------------|
| Item ID: | SKF 025 |
| Beveling Width | 3/4" max.* |
| Motor Power | 15 Amp |
| Voltage | 110V (220V / 50 Hz also available) |
| Cutting Speed | 1800 SFPM |
| Cutting Inserts | 10 inserts / 4 sided □ |
| Dimensions | 16 1/2" L x 13" H |
| Weight | 43 lbs. |

**Max bevel width may require several passes, depending on material hardness*

EASY ACCESS / SAFETY CONTROLS

ERGONOMIC HANDLES

ROLLER GUIDES FOR ACCURACY & REDUCED USER FATIGUE

PIPE BEVELING FOR PIPE OVER 6-1/4" OD

EXCEPTIONAL COOLING FOR CONTINUOUS USE

HEAVY-DUTY 10 AMP (1100 w) MOTOR

SEAMLESS ANGLE ADJUSTMENT 15° - 60°

CHAMFER WIDTH ADJUSTMENT UP TO 3/4"

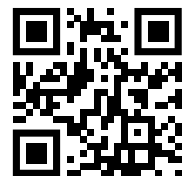

Scan to Learn More

Portable Saws and Accessories

Saws for Pipes, Structural Steel, Profiles and more p. 110-123

7-1/2" dia. Heavy-Duty Dry Cutting Air Saw

Cut up to 2-1/2" depth at 90° and 1-1/2" at 45°

Air power ideal for petrochemical, marine, demolition and fabrication industries



1.7 HP
Air Motor

- Heavy-duty air-powered circular saw, ideal for wet and dirty conditions
- Pneumatic power eliminates burn out from stalls
- 7-1/2" max. blade capacity
- D-handle design with inside trigger and safety lock button to prevent accidental starting



Optional Carbide-Tipped 7" (180mm) Dry Cut Saw Blade

Item ID: 9 2503 0120, 36T, for standard use - dry cuts metal, plastics and wood

7-1/2" dia. Heavy-Duty Dry Cut Air Saw

| | |
|-------------------|-------------------------------|
| Item ID: | 5 1116 0020 |
| Motor Power | 1.7 HP (1.3 kW) |
| Blade Diameter | 7-1/2" (190mm) |
| Max. Depth of Cut | 2-1/2" at 90° / 1-1/2" at 45° |
| Speed (Free) | 3,200 RPM |
| Air Consumption | 53 CFM at 90 PSI |
| Air Connection | 1/2" NPT |
| Vibration | <2.5 m/s ² |
| Length, Weight | 13-1/2", 14 lbs. |

* Model 5 1116 0020 also accepts 7-1/4" dia. blades
Standard equipment includes rip fence and blade wrench. Blade not included.

9" dia. Dry Cutting Air Saw for 90° and 45° Cuts

Dry cut up to 3-1/4" depth and 3/8" thick steel plate



9" diameter
(1" arbor)

- Cut steel, nonferrous metal, plastic, grating, composite and corrugated materials
- Cuts at 90° and 45° angles
- Ideal for petrochemical, marine, demolition and fabrication applications



ATEX Certified

9" dia. Dry Cut Air Saw for 90° & 45° Cuts

| | |
|-------------------|-------------------------------|
| Item ID: | 5 1115 0020 N |
| Motor Power | 2 HP (1.5 kW) |
| Blade Diameter | 9" |
| Max. Depth of Cut | 3-1/4" at 90° / 2-1/8" at 45° |
| Speed (Free) | 1,500 RPM |
| Air Consumption | 71 CFM at 90 PSI |
| Air Connection | 1/2" NPT |
| Vibration | <2.5 m/s ² |
| Weight | 19 lbs. |

Standard equipment includes an impact-resistant carrying case and Ultra-Thin LBS blade (Item ID: 722-23060).

Dry Cutting TCT Saw Blades

9" Laser Beam Saw (LBS) ultra-thin blade for all-purpose use features:

- Thinner than conventional saw blades: LBS = .055" vs. Std. = .073" thickness
- Shock-resistant, less vibration
- Produces 35% fewer chips

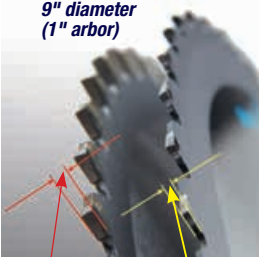

Standard blade .073" (1.85mm) thickness
Ultra-thin blade (Item ID: 722-23060) .055" (1.4mm) thickness



| Item ID: | Teeth | Thickness |
|------------|-------|-----------|
| 722-23060* | 60 | .055" |

* Standard with Model 5 1115 0020 Pneumatic Metal Saw.

Optional Tungsten Carbide-Tipped Dry Cutting Blades, 9" dia., .073" thick for Model 5 1115 0020

Item ID: 721-23048, 48T, standard use

Item ID: 721-23068, 68T, thin-wall metal

Item ID: 721-23060, 60T, aluminum

Item ID: 721-23084, 84T, sheet metal



Scan to
Learn
More

NEW Largest Cordless DRY Metal Cut Saw

Largest DRY Metal Cut Saw

| | |
|-------------------|----------------------|
| Item ID: | 608270 E |
| Voltage | 36 (2 x 18V, 5.5 Ah) |
| Blade Diameter | 12-5/8" |
| Max. Depth of Cut | 4-3/4" |
| Speed (Free) | 1,700 RPM |
| Weight | 18.5 lbs. |



Also available in 110 V



Item ID:
608302



14" Premium Super Dry
Chop Saw

Item ID:
600514NA



14" Dia. Dry Cut
Miter / Chop Saw

Dry Cutting Circular Saws – Pneumatic

Cut I-beams, 3/8" thick steel plate, insulation boards, sandwich panels, aluminum, plastics and more

- Heavy-duty air-powered circular saw
- Pneumatic power eliminates burn out from stalls and dusty jobsite conditions
- Powerful 2.4 HP motor for demanding applications
- Suction nozzle and internal chip collector for clean operation
- D-handle design with inside trigger and safety lock button to prevent accidental starting
- Ideal for steel construction, demolition and more
- 12-5/8" Dry Cutting Saw Blade included (Item ID: 608276).
- Optional Tungston Carbide Tipped Dry Cutting Blade for Stainless Steel Item ID: 608276SI



4-3/4" max. cutting depth; Cuts 3/8" thick steel plate



Scan to Learn More

Guide Rail Clamping System Available
(Item ID: 608275 SET) Rail provides straight edge length up to 55" (1,400mm).

Item ID: 608276, 84T for standard use
Item ID: 608276SI, 84T for stainless steel

12-5/8" dia. Dry Cut Air Saw

| | |
|-------------------|-----------------------|
| Item ID: | 5 1117 0020 N |
| Motor Power | 2.4 HP (1.8 kW) |
| Blade Diameter | 12-5/8" |
| Max. Depth of Cut | 4-3/4" |
| Speed (Free) | 1,200 RPM |
| Air Consumption | 71 CFM at 90 PSI |
| Air Connection | 1/2" NPT |
| Vibration | <2.5 m/s ² |
| Weight | 24 lbs. |

Dry Cutting Circular Saws – Hydraulic



ATEX Certified

**Up to 4-3/4" depth;
Cut up to 3/8" thick
steel plate**



- Powerful 3.1 HP motor for demanding applications
- Ideal for EX zone, underwater, construction and universal use
- D-handle design with inside trigger and safety lock button to prevent accidental starting
- Up to 45° miter adjustment
- Suction nozzle and internal chip collector for clean operation

7" dia. Dry Cut Air Saw

| | |
|----------------------|-------------------------------|
| Item ID: | 5 1128 0010 |
| Motor Power | 3.1 HP (2.3 kW) |
| Blade Diameter | 7" (180mm) |
| Max. Depth of Cut | 2-1/2" at 90° / 1-1/2" at 45° |
| Speed (Free) | 3,200 RPM |
| Motor Specifications | 5.25 GPM at 2000 PSI |
| Coupling | 1/2" FF (HTMA) |
| Vibration | <2.5 m/s ² |
| Weight | 22.5 lbs. |

* Model 5 1128 0020 also accepts 7-1/4" dia. blades
Standard equipment includes rip fence and blade wrench. Blade not included.

12-5/8" dia. Dry Cut Air Saw

| | |
|----------------------|--------------------------|
| Item ID: | 5 1127 0010 |
| Motor Power | 3.1 HP (2.3 kW) |
| Blade Diameter | 12-5/8" |
| Max. Depth of Cut | 4-3/4" |
| Speed (Free) | 1,800 RPM |
| Motor specifications | 5.25 - 6 GPM at 2000 PSI |
| Couplings | 1/2" FF (HTMA) |
| Vibration | <2.5 m/s ² |
| Weight | 27 lbs. |

608276 12-5/8" Dry cutting saw blade included
Available: Item ID: 608276, 84T for standard use,
Item ID: 608276SI, 84T for stainless steel

Portable Reciprocating Saws Air • Hydraulic • Electric

Hand-held or clamp-on cutting in tough environments

Ideal for a wide range of industries, including subsea, gas utilities, offshore oil, petrochemical, power generation, industrial plant maintenance and construction

- Fast cutting of pipe, structural steel, bolts, nails, pallets and other material
- The best power-to-weight ratios in the industry; compact size for cutting in confined spaces



Scan to Learn More

CHEETAH Model 5 1217 0020

1.7 HP, Cuts steel pipe and channel 1/2" to 6" dia., plastic pipe to 8" dia.



AIR ATEX Certified

IMPROVED MODEL

SHARK Model 5 1219 0010

2 HP, cuts pipe up to 6" dia., wood up to 8" dia., metal plate up to 3/4" dia.



HYDRAULIC

ATEX Certified

FOX Model 5 6002 0000

12 Amp, cuts pipe up to 6" dia., wood up to 8" dia., metal plate up to 3/4" dia.



Electric

Also Available

Model 5 6002 6000 (variable speed with dial)

Model 5 6002 7000 (variable speed with trigger)

| Item ID: | Motor Specifications | Stroke Length | Strokes per Minute | Connection | Length | Weight |
|----------------------------|--|---------------|--------------------|----------------------|--------|-----------|
| CHEETAH – Pneumatic | | | | | | |
| 5 1217 0020 | 1.7 HP, 51 CFM @ 90 PSI | 1-1/8" | 0-2300 | 1/2" NPT (ID) | 18.5" | 9.9 lbs. |
| 5 1217 0070 | Cheetah saw w/ Clamp | | | | | |
| SHARK – Hydraulic | | | | | | |
| 5 1219 0010 | 2 HP, Oil Pressure 2000 PSI, Oil Flow 6 GPM (up to 13 GPM) | 1-1/8" | 1500 | M 18 x 1.5 Female | 18" | 13.2 lbs. |
| FOX - Electric | | | | | | |
| 5 6002 6000 | 12 Amp, 110 (V220V Available) | 1-1/8" | 0-2200 | Standard 15A Plug US | 19" | 6 lbs. |
| 5 6002 7000 | | | | | | |
| 5 6002 0000 | | | | | | |

For the models above, pipe clamp Model 5 1217 9910 available for use up to 6" pipe, contact a CS Unitec specialist for details.

Low Vibration/Low Air Volume – Compact, Quiet & Reliable

Workhorses for use in the fabrication, shipbuilding, ship repair, oil and petrochemical, boat building and aircraft maintenance fields, as well as by fire and rescue professionals

- Piston air motors use low air volume while maintaining cutting speed
- Heavy-duty cast steel and aluminum saw bodies; built-in motor lubrication
- Safety STOP/Isolator button disconnects air supply



For use in hazardous areas and around gas and other flammable materials



PL Series



CL Series



Optional inside trigger for hand-held use only. Add FT to Model No.

| Model No. | Motor Power (@ 90 PSI) | Stroke Length | Strokes per Minute | Dimensions (LxHxW) | Weight (lbs.) | Connection | Noise Level dB(A) | Vibration Levels m/s ² |
|--------------|------------------------|---------------|--------------------|--|---------------|-------------|-------------------|-----------------------------------|
| PL905 | 1 HP, 4 CFM | 7/8" | 2000 | 11 ³ / ₄ " x 5 ¹ / ₄ " x 1 ⁵ / ₈ " | 5.25 | 1/4" NPT ID | 69 | 1.73 |
| CL50 | 1 HP, 5.75 CFM | 1-3/4" | 1200 | 15 ³ / ₄ " x 5 ¹ / ₄ " x 1 ⁵ / ₈ " | 5.5 | 1/4" NPT ID | 83 | 3.69 |
| CL75 | 1 HP, 5.75 CFM | 1-3/4" | 1200 | 15 ³ / ₄ " x 5 ¹ / ₄ " x 1 ⁵ / ₈ " | 5.5 | 1/4" NPT ID | 83 | 3.69 |

Optional inside trigger for handheld use only, add FT to Model # ex: PL905FT Pipe clamps available, contact CS Unitec for details.

Reciprocating Saw Blades & Accessories

Super quick and precise for pipe, steel, plastic, etc.

Saw Blades for Quick Connect Blade Holders & Allen Style Blade Holders

Mega Sharp M-Tooth Saw Blades for Freehand Cutting, Single Tang

CUTS 2x FASTER THAN ORDINARY BLADES! M42 Bi-metal for cutting steel and stainless steel
 Universal 1/2" single tang for easy mounting to quick change and allen blade holders.

The teeth of the patented M-Tooth saw blade cut on the forward and back strokes, saving time.



Metal up to 1/8" Thick

| | | |
|-------------|---------|-------------------------|
| No. 006/150 | M-Tooth | 6" L x 3/4" W x .035" T |
| No. 006/200 | M-Tooth | 7" L x 3/4" W x .035" T |

* 007D/200 extra thick for heavier-duty cutting

Metal 1/8" and Thicker

| | | |
|---------------|---------|--------------------------|
| No. 007/150 | M-Tooth | 6" L x 3/4" W x .035" T |
| No. 007/200 | M-Tooth | 8" L x 3/4" W x .035" T |
| No. 007/280 | M-Tooth | 12" L x 3/4" W x .035" T |
| No. 007D/280* | M-Tooth | 8" L x 1" W x .5" T |

General-Purpose Blades, Single Tang

General Purpose Blades – These bi-metal saw blades are made to meet demanding cutting applications in metal and more!
 Universal 1/2" single tang for easy mounting to quick change and allen blade holders.

Metal 1/8" and Thicker

| | | |
|--------------|--------|--------------------------|
| No. 3013/150 | 14 TPI | 6" L x 3/4" W x .035" T |
| No. 3013/200 | 14 TPI | 8" L x 3/4" W x .035" T |
| No. 3018/280 | 10 TPI | 12" L x 3/4" W x .035" T |

Metal up to 1/8" Thick

| | | |
|--------------|--------|-------------------------|
| No. 3014/150 | 18 TPI | 6" L x 3/4" W x .035" T |
|--------------|--------|-------------------------|

Metal up to 1/8" Thick (For Curved Cuts)

| | | |
|-------------|--------|-------------------------|
| No. 3017/90 | 18 TPI | 6" L x 3/4" W x .035" T |
|-------------|--------|-------------------------|

Cast Steel, Ductile Iron, Ceramics & Fiberglass

| | | |
|-------------|------------------|-------------------------|
| No. D12/200 | Tungsten Carbide | 8" L x 3/4" W x .035" T |
|-------------|------------------|-------------------------|

Plastic, Wood, Plasterboard

| | | |
|--------------|-------|--------------------------|
| No. 3021/150 | 6 TPI | 6" L x 3/4" W x .035" T |
| No. 3021/225 | 6 TPI | 8" L x 3/4" W x .035" T |
| No. 3021/300 | 6 TPI | 12" L x 3/4" W x .035" T |

All Woods w/ Embedded Nails

| | | |
|--------------|----------|-------------------------|
| No. 810C/150 | 8/10 TPI | 6" L x 3/4" W x .035" T |
| No. 810C/225 | 8/10 TPI | 8" L x 3/4" W x .035" T |

Saw Blades for Allen Style Blade Holders

Extra-Thick Blades, Dual Tang*

Heavy-duty Blades – These blades are much thicker than standard blades and have a stronger double-tang mount for heavy-duty cutting, either free-hand or with a clamp.

| | | | |
|---------------|--------------------|---------|-----------------------|
| No. 1001 | Cuts pipe up to 2" | 8 TPI | 6" L x 1" W x .060" T |
| No. 1002 | Cuts pipe up to 4" | 8 TPI | 8" L x 1" W x .060" T |
| No. 007D/200* | Cuts pipe up to 4" | M-Tooth | 8" L x 1" W x .050" T |

* 007D/200 has universal 1/2" single tang



Ask for special blades to cut steel.

Heavy-Duty HSS Bi-metal Blades, Dual Tang

Made of tough, resilient steel with 10/14 variable tooth pitch. Large blade width and double-shank mount deliver excellent cutting performance and durability.



| | | |
|----------|-----------|------------------------|
| No. 1005 | 10/14 TPI | 6" L x 1" W x .035" T |
| No. 1003 | 10/14 TPI | 8" L x 1" W x .035" T |
| No. 1004 | 10/14 TPI | 12" L x 1" W x .035" T |

Air Saw Blades for PL905, CL50, CL75

1/2" Wide Bi-metal Blades (CL50 / PL905)

| | | | |
|-----------|----------------|--------|----------|
| HB300/18 | Hand | 18 TPI | 12" L |
| HB300/24 | Hand | 24 TPI | 12" L |
| HB300/32 | Hand | 32 TPI | 12" L |
| MC220/18 | Machine | 18 TPI | 8 3/4" L |
| MC220/24 | Machine | 24 TPI | 8 3/4" L |
| MYN150/18 | Notched Yellow | 18 TPI | 6" L |
| MYT150/18 | Tapered Yellow | 18 TPI | 6" L |

3/4" Wide Bi-metal Blades (CL75)

| | | | |
|-------------|---------|-----------|-------|
| MB150/18 | Machine | 18 TPI | 6" L |
| MB200/10-14 | Machine | 10/14 TPI | 8" L |
| MB200/18 | Machine | 18 TPI | 8" L |
| MB200/24 | Machine | 24 TPI | 8" L |
| MB250/18 | Machine | 18 TPI | 10" L |
| MB250/24 | Machine | 24 TPI | 10" L |
| MB300/10-14 | Machine | 10/14 TPI | 12" L |
| MB300/18 | Machine | 18 TPI | 12" L |



| | | | |
|----------|---------|--------|-------|
| MB150/10 | Machine | 10 TPI | 6" L |
| MB150/24 | Machine | 24 TPI | 12" L |
| MB300/10 | Machine | 10 TPI | |

Portable Band Saws Electric • Air • Hydraulic

Fast, on-site cutting of pipe up to 8" diameter

Cold cutting saws for industry, including refineries, chemical plants, utilities, construction, offshore oil, mining, marine and demolition



Electric Band Saws



Deep Throat™:
Cut 7" round or 7" x 7"

Wide Mouth™:
Cut 8" round or 8 1/2" x 9 1/4"

Pneumatic AirBand™ Saws



Standard:
Cut 4 3/4" round or 4 1/2" x 4 3/4"



BELOW MODELS ONLY



5 6093 0100:
Cut 4" round or 4" x 4"

Includes stationary cutting table and vise



Deep Throat™:
Cut 7" round or 7" x 7"

Wide Mouth™:
Cut 8" round or 9" x 9 1/4"

Hydraulic Band Saws

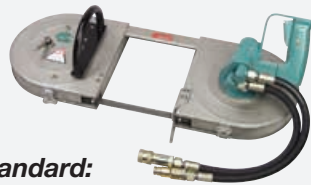

Standard:
Cut 4" round or 4" x 4"

Deep Throat™:
Cut 7" round or 7" x 7"

Wide Mouth™:
Cut 8" round or 8 1/2" x 9 1/4"

- Fast, deep, cold cutting of pipe, conduit, bolts, cable, angle iron, structural steel, chain and more
- Cut steel, stainless steel, Inconel, chrome, Hastelloy, aluminum, copper, iron, fiberglass, plastics, wood and more
- Vise clamps available for straight cutting of round, square and angular materials



Scan to
Learn More

Electric Band Saws

6 Amp, 220VAC

| Model No. | Cutting Capacity | Blade Speed (ft/sec) | Overall Length | Wt. (lbs.) |
|---|-----------------------|----------------------|----------------|------------|
| Deep Throat™ – Stainless Steel housing | | | | |
| 5 6078 0010-220 | 7" OD / 7" x 7" | 5.5-6.8 variable | 29" | 31 |
| Wide Mouth™ – Stainless Steel housing | | | | |
| 5 6079 0010-220 | 7" OD 8 1/2" x 9 1/4" | 5.6-6.8 variable | 31 1/2" | 32 |

*Equipped with 20 amp twist lock plug

Pneumatic Band Saws

| Model No. | Cutting Capacity | Motor Power (90 PSI) | Blade Speed (ft/sec) | Overall Length | Wt. (lbs.) |
|--|-----------------------------|----------------------|----------------------|----------------|------------|
| Standard AirBand™ – Aluminum Housing; 1/4" NPT ID Air Connection; 3/8" Air Hose | | | | | |
| 5 6003 0011 | 4 3/4" OD / 4 1/2" x 4 3/4" | 20 CFM | 2.2-3.3* | 21 1/2" | 14 |
| 5 6093 0010 | 4" OD / 4" x 4" | 19 CFM | 5.75 | 25" | 17* |
| Deep Throat™ AirBand – Stainless Steel housing; 1/2" NPT ID Air Connection; 1/2" Air Hose | | | | | |
| 5 6031 0010 N | 7" OD / 7" x 7" | 43 CFM | 4.0-4.9* | 28 3/4" | 28 |
| Wide Mouth™ AirBand – Stainless Steel housing; 1/2" NPT ID Air Connection; 1/2" Air Hose | | | | | |
| 5 6062 0010 | 7" OD / 8 1/2" x 9 1/4" | 43 CFM | 4.0-4.9* | 31" | 35 |

Hydraulic Band Saws

1.6 HP; Oil Flow: 4 GPM @ 2000 PSI; 1/2" FF HTMA Quick Connect Couplings

| Model No. | Cutting Capacity | Blade Speed (ft/sec) | Overall Length | Wt. (lbs.) |
|---|-------------------------|----------------------|----------------|------------|
| Standard – Stainless Steel housing | | | | |
| 5 6043 0010 | 4" OD / 4" x 4" | 4.2 | 22" | 23 |
| Deep Throat™ – Stainless Steel housing | | | | |
| 5 6041 0010 | 7" OD / 7" x 7" | 4.2 | 28 3/4" | 30 |
| Wide Mouth™ – Stainless Steel housing | | | | |
| 5 6054 0010 | 7" OD / 8 1/2" x 9 1/4" | 4.2 | 33" | 36 |

Blade guards standard on most models.

Optional guards available for

Item ID: 5 6003 0011 (saw), 1 1022 0196 (guard)

Item ID: 5 6093 0100 (saw), 5 6093 7100 (guard)

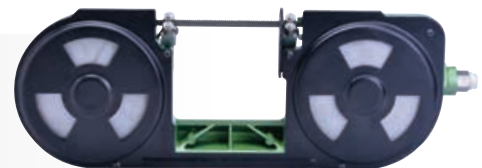

Portable Band Saw Blades and Accessories

M42 Cobalt Steel SuperBand™ Saw Blades

Blades for Models 5 6093 0100 (3/pk.)

Exact blade dimensions: 1335mm L x 13mm W x .65mm T

| | | |
|-----------------|------------|----------------------------------|
| No. 9 2506 0690 | 24 TPI | Cuts material 1/8" - 1/4" thick |
| No. 9 2506 0680 | 18 TPI | Cuts material 3/16" - 1/2" thick |
| No. 9 2506 0660 | 10/14 TPI* | Cuts material 3/16" - 1/2" thick |
| No. 9 2506 0650 | 8/12 TPI* | Cuts material 1/2" and thicker |



Blades for Model 5 6003 0011 and 5 6043 0010 (per pc.)

Blade dimensions: 44 7/8" L x 1/2" W x .025" T

| | | |
|-----------------|------------|----------------------------------|
| No. 9 2506 0010 | 18 TPI | Cuts material 1/8" - 1/4" thick |
| No. 9 2506 0020 | 14 TPI | Cuts material 3/16" - 1/2" thick |
| No. 9 2506 0030 | 10/14 TPI* | Cuts material 3/16" - 1/2" thick |
| No. 9 2506 0040 | 8/12 TPI* | Cuts material 1/2" and thicker |



Deep Throat™ Blades (Models 5 6031 0010, 5 6078 0010-220 and 5 6041 0010) (per pc.)

Blade dimensions: 66" L x 5/8" W x .025" T

| | | |
|-----------------|------------|----------------------------------|
| No. 9 2506 0230 | 10/14 TPI* | Cuts material 3/16" - 1/2" thick |
| No. 9 2506 0240 | 8/12 TPI* | Cuts material 1/2" and thicker |



Wide Mouth™ Blades (Model Nos. 5 6062 0010, 5 6079 0020-220 and 5 6054 0010) (per pc.)

Blade dimensions: 71" L x 5/8" W x .025" T

| | | |
|-----------------|------------|----------------------------------|
| No. 9 2506 0350 | 10/14 TPI* | Cuts material 3/16" - 1/2" thick |
| No. 9 2506 0340 | 8/12 TPI | Cuts material 1/2" and thicker |
| No. 9 2506 0330 | 6/10 TPI | Cuts material 3/4" and thicker |



* Variable tooth pitch saw blades cut faster and last longer than standard single pitch blades. Variable tooth size and gullet depth reduce harmonic vibration for quieter, more efficient cutting. Standard equipment on all portable band saws are 10/14 TPI.

Vise Clamps for Accurate Cuts

- Securely clamp to round, square and angular materials for straight cutting
- Easily attach to CS Unitec Portable Band Saws

Clamp-on vise for 4-3/4" Band Saw

Model No. 5 6030 9000

(for saw 5 6043 0010)

Max. material size – rounds: 4 3/4"; squares: 4 1/2"; angles: 4 1/2"

Clamp-on vise for 7" Deep Throat™ Band Saws

Model No. 5 6031 9400

(for saw 5 6031 0010, 5 6078 0010-220 and 5 6041 0010)

Max. material size – rounds: 7"; squares: 5"; angles: 5"



Power Hacksaws Air • Electric • Hydraulic

Cold cutting of large pipe up to 30" diameter and structural steel – on site

Ideal for a wide range of industries, including refineries, chemical plants, utilities, construction, offshore oil, mining, marine and demolition

- Cold cutting of large pipe, structural steel, tanks, profiles and more
- Compact size for cutting in confined spaces



Model 5 1212 0050

AIR



Model 5 1215 0070

ELECTRIC



Model 5 1220 0050

HYDRAULIC



| Model No. | Power | Throttle | ATEX EX Zone Certification (If Applicable) | Strokes per Min. | Blade Stroke | Hose | Wt. (lbs.) |
|--|--------|----------|--|------------------|---------------------------------|---------|------------|
| Pneumatic – 3/4" ID NPT Air Connection (Air Consumption: 51 CFM @ 90 PSI) | | | | | | | |
| 5 1212 0010 | 1.5 HP | Roll | N/A | 100-350 | 2 ³ / ₈ " | 1/2" | 16.5 |
| 5 1212 0050 | 1.5 HP | Lever | N/A | 100-350 | 2 ³ / ₈ " | 1/2" | 16.5 |
| 5 1212 0050A | 1.5 HP | Lever | II2GExhIIBT5Gb | 100-350 | 2 ³ / ₈ " | 1/2" | 16.5 |
| NEW 5 1232 0050 | 1.5 HP | Lever | II2GExhIIBT5Gb | 100-350 | 2 ³ / ₈ " | 1/2" | 16.5 |
| NEW 5 1232 0010 | 1.5 HP | Roll | II2GExhIIBT5Gb | 100-350 | 2 ³ / ₈ " | 1/2" | 16.5 |
| Electric – 11 Amps / 110 Volt (Also available as 220 Volt/50 Hz) | | | | | | | |
| 5 1215 0070 | 1.5 HP | Trigger | 110V/60 Hz | 60-500 | 2 ³ / ₈ " | Cable | 16.5 |
| Hydraulic – 1/2" FF (HTMA) Quick Connect Couplings | | | | | | | |
| NEW 5 1230 0050 | 3.8 HP | Lever | II2GExhIIBT5Gb | 100-500 | 2 ³ / ₈ " | 1/2" ID | 24.2 |
| NEW 5 1230 0010 | 3.8 HP | Roll | II2GExhIIBT5Gb | 100-500 | 2 ³ / ₈ " | 1/2" ID | 24.2 |
| 5 1220 0050 | 3.8 HP | Lever | II2GExhIIBT5Gb | 100-500 | 2 ³ / ₈ " | 1/2" ID | 24.2 |
| 5 1220 0010 | 3.8 HP | Roll | II2GExhIIBT5Gb | 100-500 | 2 ³ / ₈ " | 1/2" ID | 24.2 |

NEW Hacksaw Models Include:

- Up to 75% reduction in cost of ownership
- Improved design for increased saw life
- Increased stability to reduce tool wear
- Improved sealing for increased corrosion resistance
- Increased water resistance for hydraulic saw underwater applications



Scan for
**Full Hacksaw
Line**

Assorted pipe clamps for pipes up to 30" OD or profile clamps for structural steel

Manual or automatic feed (see page 118)

Heavy-duty saw blades from 8" to 37" long (see page 117, 118)

HSS, HSS-SL, and carbide-coated blades available



Pneumatic:
3/4" NPT Connection
Electric:
110 Volt (220V available)
Hydraulic:
1/2" FF (HTMA) Quick Connect Couplings

Throttle Types for Pneumatic Saws:



Roll Throttle
(air model 5 1212 0010)
used only with automatic feed clamps

Lever Throttle
(model 5 1212 0050)
on/off for manual clamps

Metal carrying case available Item ID: 9 9910 0080 for electric and hydraulic saws

Heavy Duty Hacksaw Blades

CUT UP TO 60% FASTER THAN STANDARD BLADES

- Cut ferrous & non-ferrous metal, extremely hard specialty alloy steels, and more!
- Designed to reduce blade wear and quickly remove chips to increase productivity
- Increased durability for extended blade life

**Ideal for: Aluminum • Steel/Stainless
Cast Iron • Wood/Plastic • Masonry**

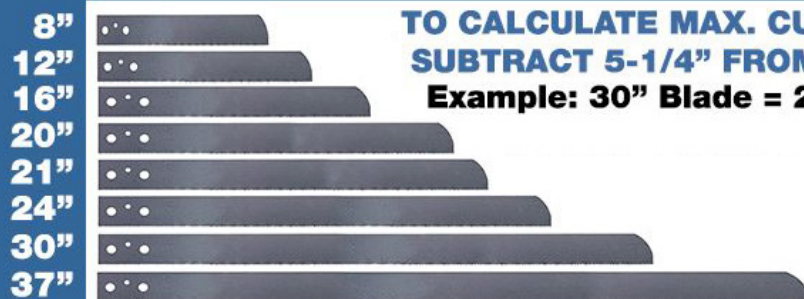

Scan for
Full Line

NEW! FAST CUT Hacksaw Blades

UP TO 60% FASTER THAN STANDARD BLADES!

| Item ID: | Length | Teeth/Inch | Thickness | Material | Max. Dia. of Cut |
|----------------|--------|------------|-----------|------------------------------|----------------------------------|
| Z23-6 HSS | 12" | 14 | 5/64" | Steel | 6-5/8" |
| Z23-6 HSS-SL* | 12" | | 5/64" | Cast Iron, Aluminum, Plastic | 6-5/8" |
| Z23-33 HSS | 18" | 6-8 | 5/64" | Cast Iron, Aluminum, Plastic | 12 ³ / ₄ " |
| Z23-33 HSS-SL* | 18" | 6-8 | 5/64" | Cast Iron, Aluminum, Plastic | 12 ³ / ₄ " |
| Z23-29 HSS | 18" | 8 | 5/64" | Cast Iron, Aluminum, Plastic | 12 ³ / ₄ " |
| Z23-29 HSS-SL* | 18" | 8 | 5/64" | Cast Iron, Aluminum, Plastic | 12 ³ / ₄ " |
| Z23-7 HSS | 18" | 14 | 5/64" | Steel | 12 ³ / ₄ " |
| Z23-7 HSS-SL* | 18" | 14 | 5/64" | Stainless Steel | 12 ³ / ₄ " |
| Z23-72 HSS | 22" | 6-8 | 5/64" | Cast Iron, Aluminum, Plastic | 16 ³ / ₄ " |
| Z23-72 HSS-SL* | 22" | 6-8 | 5/64" | Cast Iron, Aluminum, Plastic | 16 ³ / ₄ " |
| Z23-30 HSS | 22" | 8 | 5/64" | Cast Iron, Aluminum, Plastic | 16 ³ / ₄ " |
| Z23-30 HSS-SL* | 22" | 8 | 5/64" | Cast Iron, Aluminum, Plastic | 16 ³ / ₄ " |
| Z23-73 HSS | 22" | 14 | 5/64" | Steel | 16 ³ / ₄ " |
| Z23-73 HSS-SL* | 22" | 14 | 5/64" | Stainless Steel | 16 ³ / ₄ " |
| Z23-45 HSS | 26" | 6-8 | 5/64" | Cast Iron, Aluminum, Plastic | 20 ³ / ₄ " |
| Z23-45 HSS-SL* | 26" | 6-8 | 5/64" | Cast Iron, Aluminum, Plastic | 20 ³ / ₄ " |
| Z23-74 HSS | 26" | 8 | 5/64" | Cast Iron, Aluminum, Plastic | 20 ³ / ₄ " |
| Z23-74 HSS-SL* | 26" | 8 | 5/64" | Cast Iron, Aluminum, Plastic | 20 ³ / ₄ " |
| Z23-79 HSS | 26" | 14 | 5/64" | Steel | 20 ³ / ₄ " |
| Z23-79 HSS-SL* | 26" | 14 | 5/64" | Stainless Steel | 20 ³ / ₄ " |
| Z23-76 HSS | 30" | 6-8 | 5/64" | Cast Iron, Aluminum, Plastic | 24 ³ / ₄ " |
| Z23-76 HSS-SL* | 30" | 6-8 | 5/64" | Cast Iron, Aluminum, Plastic | 24 ³ / ₄ " |
| Z23-78 HSS | 30" | 8 | 5/64" | Cast Iron, Aluminum, Plastic | 24 ³ / ₄ " |
| Z23-78 HSS-SL* | 30" | 8 | 5/64" | Cast Iron, Aluminum, Plastic | 24 ³ / ₄ " |
| Z23-75 HSS | 30" | 14 | 5/64" | Steel | 24 ³ / ₄ " |
| Z23-75 HSS-SL* | 30" | 14 | 5/64" | Stainless Steel | 24 ³ / ₄ " |
| Z23-37 | 37" | 14 | 5/64" | Steel | 31 ³ / ₄ " |
| Z23-37 HSS-SL* | 37" | 14 | 5/64" | Stainless Steel | 31 ³ / ₄ " |

* Use HSS-SL Blades for best cutting performance on stainless steel and hard metal. Blades for plastic, wood and masonry also available.

Heavy Duty Hacksaw Blades (cont.)

Extra-Thick Hacksaw Blades

HEAVY-DUTY CUTTING OF PIPE AND STRUCTURAL STEEL

- Cut steel, stainless steel, aluminum, cast iron, wood, plastic, masonry & more!
- Extra thick blades for 90° cutting
- 3 grades of blades for wide variety of applications



Scan for Full Line

| Item ID: | Length | Teeth/Inch | Thickness | Material | Max. Dia. of Cut |
|----------------|--------|------------|-----------|-----------------|------------------|
| Z22-9 HSS | 8" | 8 | 1/16" | Steel/Aluminum | 3 1/8" |
| Z22-10 HSS | 8" | 16 | 1/16" | Steel | 3 1/8" |
| Z22-10 HSS-SL* | 8" | 16 | 1/16" | Stainless Steel | 3 1/8" |
| Z22-11 HSS | 8" | 24 | 1/16" | Sheet Metal | 3 1/8" |
| Z22-6 CARBIDE | 12" | Coated 16 | 3/16" | Masonry | 6 5/8" |
| Z22-71 HSS | 12" | 4 | 1/16" | Plastics/Wood | 6 5/8" |
| Z22-6 HSS | 12" | 16 | 1/16" | Steel | 6 5/8" |
| Z22-6 HSS-SL* | 12" | 16 | 1/16" | Stainless Steel | 6 5/8" |
| Z22-31 HSS | 12" | 12 | 1/16" | Steel | 6 5/8" |
| Z22-7 HSS-SL* | 16" | 16 | 1/16" | Stainless Steel | 10 5/8" |
| Z22-7 CARBIDE | 16" | Coated 16 | 1/16" | Masonry | 10 5/8" |
| Z22-32 HSS | 16" | 4 | 1/16" | Plastics/Wood | 10 5/8" |
| Z22-40 HSS | 21" | 4 | 1/16" | Plastics/Wood | 10 5/8" |
| Z22-7 HSS | 16" | 16 | 1/16" | Steel | 10 5/8" |
| Z22-29 HSS | 16" | 8 | 1/16" | Steel/Aluminum | 10 5/8" |
| Z22-33 HSS | 16" | 6 | 1/16" | Cast Iron | 10 5/8" |
| Z22-72 CARBIDE | 20" | Coated 14 | 3/16" | Masonry | 14 5/8" |
| Z22-72 HSS | 20" | 14 | 5/64" | Steel | 14 5/8" |
| Z22-30 HSS | 21" | 12 | 1/16" | Steel | 15 5/8" |
| Z22-30 HSS-SL* | 21" | 12 | 1/16" | Stainless Steel | 15 5/8" |
| Z22-73 HSS-SL* | 24" | 14 | 5/64" | Stainless Steel | 18 1/2" |
| Z22-73 CARBIDE | 24" | Coated 14 | 3/16" | Masonry | 18 1/2" |
| Z22-73 HSS | 24" | 14 | 5/64" | Steel | 18 1/2" |
| Z22-74 HSS | 24" | 8 | 5/64" | Steel/Aluminum | 18 1/2" |
| Z22-75 HSS | 30" | 12 | 5/64" | Steel | 24 7/8" |
| Z22-75 HSS-SL* | 30" | 12 | 5/64" | Stainless Steel | 24 7/8" |
| Z22-76 HSS | 30" | 6 | 5/64" | Cast Iron | 24 7/8" |
| Z22-37 HSS | 37" | 12 | 5/64" | Steel | 31 7/8" |
| Z22-37 HSS-SL | 37" | 12 | 5/64" | Stainless Steel | 31 7/8" |

* Use HSS-SL Blades for best cutting performance on stainless steel and hard metal. Blades for plastic, wood and masonry also available.

Hacksaw Clamps and Blade Guides

| Model No. | Cutting Diameter | Description |
|-------------|-------------------|--|
| 5 1207 9910 | 2" to 6" | Pipe Clamp |
| 5 1202 9960 | 4" to 12 3/4"* | Pipe Clamp |
| 5 1207 9970 | Up to 13" OD | Blade Guide |
| 5 1207 8910 | Up to 21" OD | Blade Guide |
| 5 1202 8970 | 21 5/8" x 11 3/8" | Profile Clamp |
| 5 1208 9980 | Up to 12 3/4"* | Automatic - Self-feeding Clamp (for pneumatic saws) |
| 5 1208 9990 | Up to 12 3/4"* | Automatic - Self-feeding (for electric and hydraulic saws) |



Model 5 1202 9960 Pipe Clamp for 4" to 12 3/4" dia.*

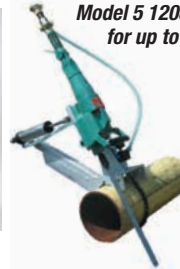

Model 5 1208 9990 Self-feeding Pipe Clamp for up to 12 3/4" dia. electric and hydraulic saws*



5 1201 9010 - Extension chain 17" | 5 1201 9030 - Extension chain 39"

* Cut up to 30" OD with two extension chains (order 2x Item ID: 5 1201 9030)



Cut pipe up to 63" dia. with wall thickness up to 2"

Ideal for use in municipal water and gas utilities, petrochemical, power generation, plant maintenance, pipe line construction, marine and demolition applications.

- Heavy-duty, versatile air and hydraulic pipe cutting machines
- Cut pipe quickly from 6" to 63" dia. with wall thicknesses from 1/4" to 2"
- Use on steel, ductile iron, nonferrous metal, HDPE, plastic, concrete pipe and more
- Cut pipe underground with minimal excavation
- 7" blade with adjustable cutting depth and fully enclosed blade guard
- Machine is manually guided with hand lever feed to make a 360° cut in pipe at 90 degrees
- Guide chain is adjustable by adding and removing chain links
- ATEX certified for use in Ex Zones (ATEX II 2G Ex h IIB T6 Gb)

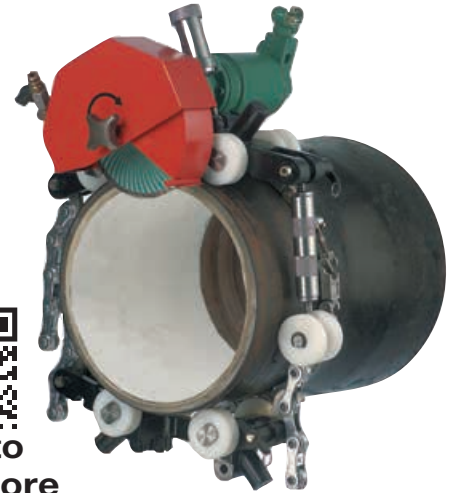

Scan to
Learn More

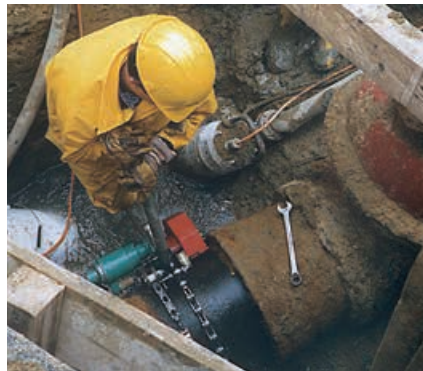

Pneumatic Models
Item ID: 5 8010 0050
Item ID: 5 8002 7000

Features include:

- Fast cutting of pipe
- Adjustable cutting depth
- Fully enclosed blade guard
- Cooling water connection
- Carbide-tipped or diamond-coated blades

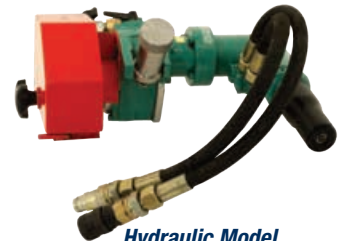

Hydraulic Model
Item ID: 5 8006 7000

When ordering, specify pipe diameter and application for assistance with determining required blade, feed handle, guide carriage & chain and tensioning chain & tensioner.

| Item ID: | Power | Blade Arbor | Motor Specifications | Speed (RPM) | Blade Dia. | Hose Connection | Weight (lbs.) |
|------------------------|--------|-------------|-------------------------|-------------|------------|-----------------|---------------|
| Pneumatic Motor | | | | | | | |
| 5 8002 7000 | 2.4 HP | 7/8" | 77 CFM @ 90 PSI | 350/1800 | 7" | 1/2" NPT | 28 |
| 5 8010 0050 | 4 HP | 7/8" | 106 CFM @ 90 PSI | 1800 | 7" | 3/4" NPT | 28 |
| Hydraulic Motor | | | | | | | |
| 5 8006 7000 | 2.7 HP | 7/8" | 6-13 Gallons @ 2000 PSI | 350/1800 | 7" | 1/2" FF (HTMA) | 28 |

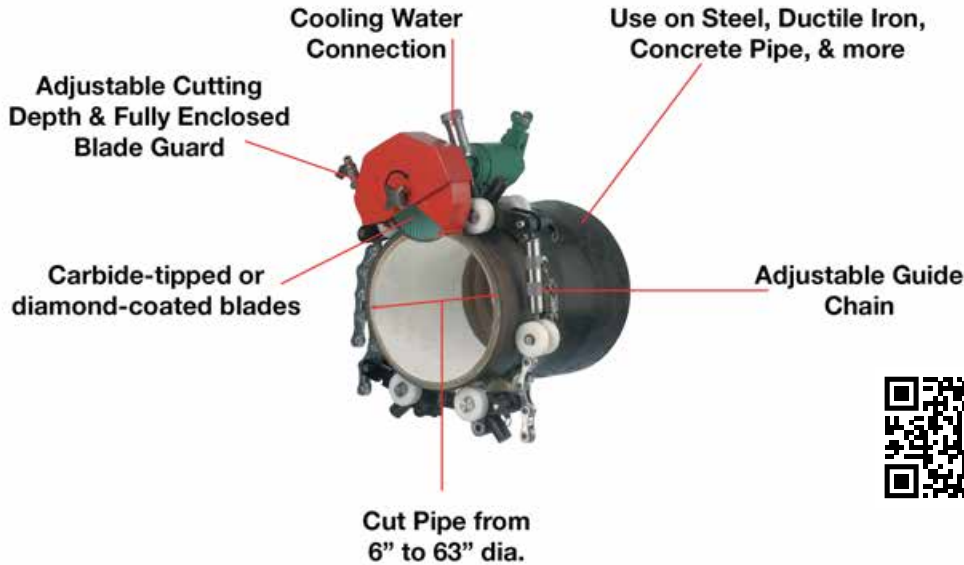

View a demonstration of our versatile pipe cutting machine:



Pipe Cutting Machine Kits

| For Pipe Diameters | Pneumatic Kit Item ID: (4 HP) | Pneumatic Kit Item ID: (2.4 HP) | Hydraulic Kit Item ID: (2.7 HP) |
|------------------------|-------------------------------|---------------------------------|---------------------------------|
| 6" to 16" (150-400mm) | 5 8010 16PK | 5 8002 16PK | 5 8006 16HK |
| 6" to 32" (150-800mm) | 5 8010 32PK | 5 8002 32PK | 5 8006 32HK |
| 6" to 63" (150-1600mm) | 5 8010 63PK | 5 8002 63PK | 5 8006 63HK |

Pneumatic Kits (1 & 2-Speed)*

Select Appropriate Kit Based on Pipe Diameter

For cutting pipe with diameter greater than 63", please contact CS Unitec for help identifying necessary components.

| 6" to 16" (150-400mm) | 6" to 32" (150-800mm) | 6" to 63" (150-1600mm) |
|--|--|--|
| Kit 5 8010 16PK or 5 8002 16 PK | Kit 5 8010 32PK or 5 8002 32PK | Kit 5 8010 63PK or 5 8002 63PK |
| (1) Drive Unit Item ID: 5 8010 0050 or 5 8002 7000 | (1) Drive Unit Item ID: 5 8010 0050 or 5 8002 7000 | (1) Drive Unit Item ID: 5 8010 0050 or 5 8002 7000 |
| (1) Guide Carriage, small Item ID: 5 8010 8090 | (1) Guide Carriage, small Item ID: 5 8010 8090 | (2) Guide Carriage, small Item ID: 5 8010 8090 |
| (1) Chain Tensioner, small PN 5 8003 8300 | (1) Chain Tensioner, small PN 5 8003 8300 | (1) Chain Tensioner, small PN 5 8003 8300 |
| (1) Guide Chain, 16" OD (24 chain links) Item ID: 5 8002 8760 | (1) Guide Carriage, large Item ID: 5 8010 8100 | (2) Guide Carriage, large Item ID: 5 8010 8100 |
| (1) 7" Dia. Carbide-tipped blade Item ID: 9 2503 0120 | (1) Chain Tensioner, large Item ID: 5 8002 8400 | (2) Chain Tensioner, large Item ID: 5 8002 8400 |
| (1) 7" Dia. Diamond blade Item ID: 9 2503 0100 | (1) Tensioning Chain Item ID: 5 8002 8710 | (2) Tensioning Chain Item ID: 5 8002 8710 |
| (1) Tool Kit Item ID: 5 8002 9200 | (1) Guide Chain, 32" OD (46 chain links) Item ID: 5 8002 8780 | (1) Guide Chain, 63" OD (90 chain links) Item ID: 5 8002 8830 |
| (1) Steel Transport Box Item ID: 5 8002 9300 | (1) 7" Dia. Carbide-tipped blade Item ID: 9 2503 0120 | (1) 7" Dia. Carbide-tipped blade Item ID: 9 2503 0120 |
| | (1) 7" Dia. Diamond blade Item ID: 9 2503 0100 | (1) 7" Dia. Diamond blade Item ID: 9 2503 0100 |
| | (1) Tool Kit Item ID: 5 8002 9200 | (1) Tool Kit Item ID: 5 8002 9200 |
| | (1) Steel Transport Box Item ID: 5 8002 9300 | (1) Steel Transport Box Item ID: 5 8002 9300 |

Hydraulic Kits (2-Speed)*

Select Appropriate Kit Based on Pipe Diameter

For cutting pipe with diameter greater than 63", please contact CS Unitec for help identifying necessary components.

| 6" to 16" (150-400mm) | 6" to 32" (150-800mm) | 6" to 63" (150-1600mm) |
|--|--|--|
| Kit 5 8006 16HK | Kit 5 8006 32HK | Kit 5 8006 63HK |
| (1) Drive Unit Item ID: 5 8006 7000 | (1) Drive Unit Item ID: 5 8006 7000 | (1) Drive Unit Item ID: 5 8006 7000 |
| (1) Guide Carriage, small Item ID: 5 8010 8090 | (1) Guide Carriage, small Item ID: 5 8010 8090 | (1) Guide Carriage, small Item ID: 5 8010 8090 |
| (1) Chain Tensioner, small Item ID: 5 8003 8300 | (1) Guide Carriage, large Item ID: 5 8010 8100 | (1) Guide Carriage, large Item ID: 5 8010 8100 |
| (1) Guide Chain, 16" OD (24 chain links) Item ID: 5 8002 8760 | (1) Chain Tensioner, large Item ID: 5 8002 8400 | (1) Chain Tensioner, large Item ID: 5 8002 8400 |
| (1) 7" Dia. Carbide-tipped blade Item ID: 9 2503 0120 | (1) Tensioning Chain Item ID: 5 8002 8710 | (1) Tensioning Chain Item ID: 5 8002 8710 |
| (1) 7" Dia. Diamond blade Item ID: 9 2503 0100 | (1) Guide Chain, 32" OD (46 chain links) Item ID: 5 8002 8780 | (1) Guide Chain, 63" OD (90 chain links) Item ID: 5 8002 8830 |
| (1) Steel Transport Box Item ID: 5 8002 9300 | (1) 7" Dia. Carbide-tipped blade Item ID: 9 2503 0120 | (1) 7" Dia. Carbide-tipped blade Item ID: 9 2503 0120 |
| | (1) Tool Kit Item ID: 5 8002 9200 | (1) Tool Kit Item ID: 5 8002 9200 |
| | (1) Steel Transport Box Item ID: 5 8002 9300 | (1) Steel Transport Box Item ID: 5 8002 9300 |

* The 2-speed motor is included in the Pipe Cutting Machines for cutting and beveling. Beveling cutters sold separately.

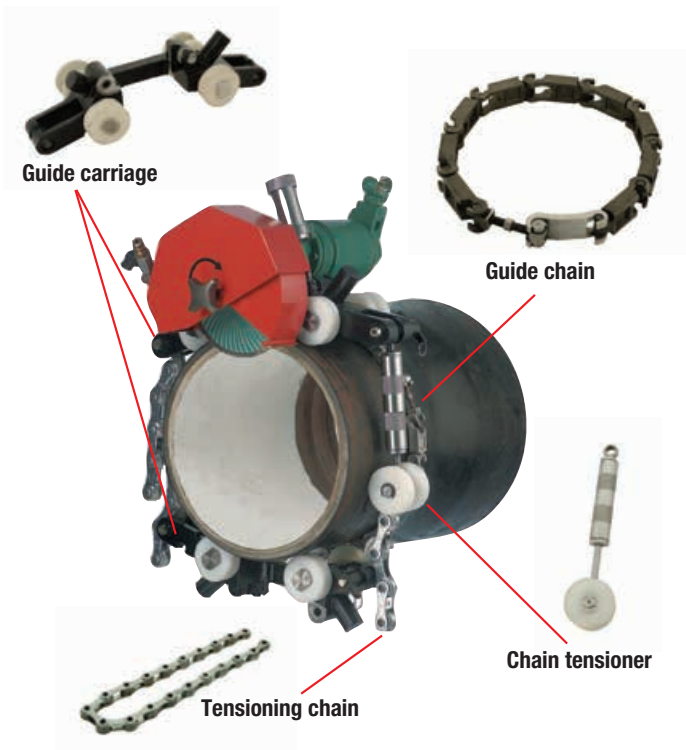

- **Guide Carriages** are for both saw mounting and movement for added leverage to reduce user effort
- **Guide Chains** provide a stationary track to ensure a straight, 90° cut
- **Saw Blades** allow for cutting steel, stainless steel, plastics, HDPE, PVC, Ductile Iron, cast iron, concrete, & clay up to a 7" diameter & 2" depth
- **Tensioning Chain** allows the pipe cutting machine to smoothly roll while holding the saw firm against the pipe's surface

For a list of contents included with Pipe Cutting Machine Kits, visit our website at:
www.csunitec.com/saws/pipe-cutting-machines
or Scan the QR Code!



Guide Chain

All guide chains include tightener

| Item ID: | Description |
|-------------|----------------|
| 5 8002 8760 | 24 chain links |
| 5 8002 8770 | 35 chain links |
| 5 8002 8780 | 46 chain links |
| 5 8002 8810 | 57 chain links |
| 5 8002 8790 | 68 chain links |
| 5 8002 8820 | 79 chain links |
| 5 8002 8830 | 90 chain links |



Chain Link

Item ID: 5 8001 8750 (Length: 2-1/4")
Chain Link Set (5 connected links)
 Item ID: 5 8001 8860 (Length: 11-1/4")
Chain Link Set (6 connected links)
 Item ID: 5 8001 8960 (Length: 6 x 2-1/4")
 Magnet for Easy Setup!



Tightener – Item ID: 5 8002 6800

Tensioning Chain

Small Chain Tensioner
 Item ID: 5 8003 8300



Large Chain Tensioner
 Item ID: 5 8002 8400



Tensioning Chain
 Length: 37-3/8" (950mm)
 Item ID: 5 8002 8710



Guide Carriages



Small Guide Carriage – Item ID: 5 8010 8090
Large Guide Carriage – Item ID: 5 8010 8100

Feeding Pipe – Item ID: 5 8002 9500

7" Saw Blades – for 2" max. cutting depth



Carbide-Tipped Blade
 Item ID: 9 2503 0120
 For steel, stainless steel (min. 1/4" wall thickness), plastics, HDPE 6-1/4" also available for 6" OD pipe cutting Item ID: 9 2503 0090



Diamond Blade
 Item ID: 9 2503 0100
 For cast iron, ductile iron, cement, concrete and clay
 6" also available for 6" OD pipe cutting Item ID: 9 2503 0075

Beveling Cutters



45° Beveling Cutter –
 Item ID: 9 2530 7040

90° Beveling Cutter –
 Item ID: 9 2530 7090



60° Beveling Cutter –
 Item ID: 9 2530 7060

Nibblers

Cut Steel Up To 3/8" Thick

- Fast cutting without feed force, distortion, or sparks.
- Reduced fatigue and ergonomic fitment
- Easily rotate the direction of cut up to 360°
- Clear view of the work surface
- Heavy-duty punches for cutting steel and more!
- Cut over 90 degree bends with optional die accessory
- Two-speed models available for faster cutting!

Ideal for wide range of applications from cutting sheet metal, steel plate, weldments, I-beam, tanks, double sheets & more



| Item ID: | Power | RPM | Working Speed (ft/Min) | Start Hole Dia. | Min. Radius | Max Material Thickness Steel / Stainless / Aluminum | Weight (lbs.) |
|-----------|---------------|---------|------------------------|-----------------|-------------|---|---------------|
| CS-350-E | 12 Amp, 110 V | 0-650 | 4 | 1.25" | 0.28" | 0.135" / 0.09" / 0.135" | 7.5 |
| CS-500-E | 12 Amp, 110 V | 0-600 | 4.5 | 1.25" | 3.125" | 0.197" / 0.135" / 0.276" | 8.5 |
| CS-700-E | 15 Amp, 110 V | 400 | 5 | 2.75" | 5.5" | 0.276" / 0.197" / 0.394" | 26 |
| CS-3400-E | 15 Amp, 110 V | 230/370 | 5.2 | 3" | 16" | 0.375" / 0.276" / 0.5" | 32 |

All models also available in 220 V

To learn more and see available accessories & consumables, Scan Here:



Air Tool Accessories

Dryers/Cleaner & Filters



Model CSAP-2

- Removes moisture and dirt from air lines; a float valve automatically ejects water and dirt
- Includes automatic oiler
- Connections for two tools, max. air flow 185 CFM



Model 9 2406 0650

- Removes moisture and dirt from air lines
- Adjustable air pressure 0-140 PSI, maintains constant downstream pressure
- Maximum air volume 125 CFM

Lubricants & Conditioners



- Air Tool Lubricant
ProLube-ATL - Item ID: CS 7043-001 (gallon)
- Air Tool Lubricant with Anti-Freeze
ProLube-ATL/AF - Item ID: CS 7049-001 (gallon)
- Air Tool Line Conditioner/Cleaner
For use in underwater air tools – displaces moisture and inhibits rust and corrosion of air motors - Item ID: 9109 (5 Liters)

Whip Hoses

| Item ID: | Tool Fitting | Integral Swivel Fitting (MPT) | Hose Connection |
|----------|--------------|-------------------------------|-----------------|
| 14HW-HYD | 1/4" | 0-650 | 1/2" ID x 6' |
| 38HW-HYD | 3/8" | 0-600 | |
| 12HW-HYD | 1/2" | 400 | |

Whip Checks

- Item ID: CS-WHIPCHECK1
- For 1/2" to 1-1/4" OD
- Item ID: CS-WHIPCHECK2
- For 1-1/2" to 3" OD



Whip Hoses with Inline Oilers

| Item ID: | Tool Fitting | Lubricator Connection | Hose Connection |
|------------------|--------------|-----------------------------------|-----------------|
| CS-1HW-HDS | 1/4" | O-R w/ CP (Chicago Style Fitting) | 1/2" ID x 6' |
| CS-2HW-HDS | 3/8" | | |
| CS-3HW-HDS | 1/2" | | |
| CS-4HW-0.500-HDS | 1/2" | | |



**For Air & Hydraulic Hose Needs,
Please Contact a
CS Unitec Specialist**

Hydraulic Tool Accessories

Hydraulic Power Units

- Ideal for use with our hydraulic power tools.
- Easy to move with lift and latch handle

The Hydraulic Power Unit is available with gas, electric or diesel engines upon request. Contact us for more information.



| Item ID: | HP | GPM (LPM) | Output Pressure (PSI) | Weight |
|--------------------------------|----|--------------------|-----------------------|----------|
| Gas: P95 Electric 3PH: P95E | 18 | 5 - 8 (19 - 30) | 2000 | 330 lbs. |
| Gas: CSM300-23G-HPP | 23 | 8-14 (30 - 53) | 2500 | 450 lbs. |

**Pressure reducers also available:
CS 70350 for reducing earth moving equipment 5000 psi to 2000 psi, 2 2406 9900 reduces 5075 psi to 1160 psi
2 2406 9700 reduces 2000 psi to 1160 psi**

Also Available from CS Unitec

CS Unitec, Inc. specializes in industrial power tools and safety tools for construction and industry.

Innovation and high quality are synonymous with CS Unitec's power tools. In 1991, the company invented the first pneumatic portable band saw. CS Unitec has added to its list of industry firsts with the widest range of portable magnetic drills and hand-held concrete core drills. The line also includes surface preparation tools for metal, concrete and masonry, air, electric and hydraulic portable band saws, reciprocating saws, hacksaws, nut runners, rotary hammer drills, rolling motors, non-sparking safety tools, portable mixers and dust extraction vacuum systems.

For tool specifications and ATEX and Ex Zone information, visit CSunitec.com.

Call 1-800-700-5919 or 203-853-9522 to request any of the catalogs shown below.

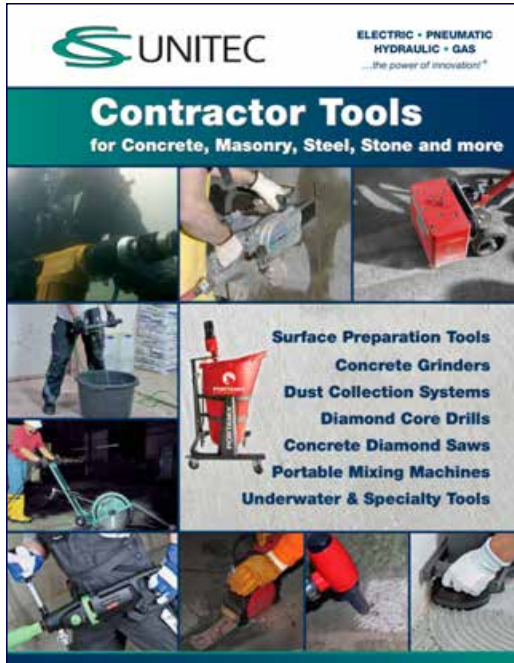

Contractor Tools:
Surface Preparation Tools, Concrete Grinders, Dust Collection Systems, Diamond Core Drills, Air Concrete Saws and more



Safety Tools for Hazardous & Explosive Environments:
Non-Sparking, Non-Magnetic, Corrosion Resistant Hand Tools
Power Tools for use in Ex Zones, Hydrogen, ATEX Zones and Hazardous Environments

High Performance Power Tools & Accessories

DRILL • SAW • SURFACE PREP • METAL FINISHING • MIXING • NON-SPARKING

View demo videos at
www.csunitec.com



... the power of innovation!®



View product demonstrations
at www.csunitec.com.

CS UNITEC, Inc. 22 Harbor Avenue, Norwalk, CT 06850
4330 Center St., Deer Park, TX 77536

Phone 800-700-5919 • 203-853-9522 • Fax 203-853-9921

Email info@csunitec.com • www.csunitec.com

ALL SPECIFICATIONS ARE SUBJECT TO CHANGE

© Copyright 2026, CS Unitec, Inc.