



EIBENSTOCK

Vakuumpumpe

Original Instructions



Diamond Drill Rigs

BST 104/60 V

Important Instructions

Important instructions and warning notices are allegorized on the machine by means of symbols:



Warning: general precaution



Warning: dangerous voltage



Warning: hot surface



Tool, drill bit and rig are heavy – Caution: risk of squashing



Danger of tearing or cutting

During work you should wear goggles, ear protectors, protective gloves, and sturdy work clothes!



Wear ear protection



Wear safety goggles



Wear protective helmet



Wear protective gloves



Wear protective boots

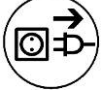

Do disconnect from power before working on the tool!

Technical Characteristics

Diamond Drill Rigs BST 104/60 V

Length of the column:	26 ¾"
Max. drilling diameter	5 ¼"
Inclination:	45° - 90°
Locking in top position:	Yes
Fixture of the motor:	collar clamping Ø 60mm
Adaptation to surface:	4 positioning screws / 2 bubble levels
Weight:	18,7 lbs.

Supply

Diamond drill rig with turnstile and operating instructions in a cardboard box.

Application for Indented Purpose

The diamond drill rig **BST 104/60 V** is made for diamond core drills with a collar diameter from 60mm.

The max. drilling diameter for the BST 104/60 V must not exceed 5 ¼".

In case of wrong handling or misuse, the producer does not assume any liability.

Use



After each readjustment always check that the screws are tightly fixed so that safe operating of the drill rig is possible.

Mounting the turnstile

- Mount the turnstile (1) on the right or left side of the carriage (2) depending on the work to be performed.
- Check whether the turnstile (1) is fixed tightly.

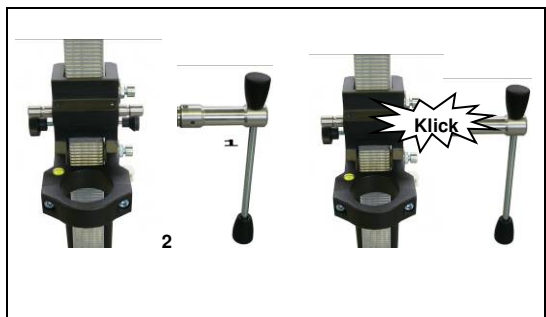

Fastening of the Drill Rig

Fastening on the floor by means of vacuum

Don't use the vacuum mounting on the wall and overhead!

For a low-pressure mounting the surface where the base is mounted must be not porous and must be flat and free of cracks. If this is not the case, this kind of mounting can't be used. For the vacuum mounting you need a vacuum pump and a vacuum hoses (see illustration). These items are available on request.



Connect the drill rig an the vacuum pump by means of a vacuum hose.

Get the drill rig in the correct position and switch on the pump.

Make sure, that all four levelling screws in the foot plate are turned back and that a low pressure of -0,8 bar is reached.

By means of pressing the valve button in the handle the drill stand can be unburdened (vacuum is escaping) and can be readjusted.

The vacuum pump must run during the whole working time and must be placed so that one can see the manometer.

Make sure that the drill stand is fixed firmly before you start drilling!

Fastening by means of dowels in concrete

To mount the drill stand by means of dowels it is necessary to remove the vacuum grip and the base gasket from the base plate.

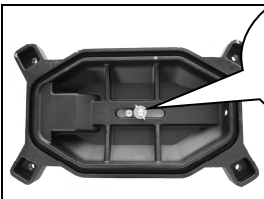

Loosen and remove the fastening nut.

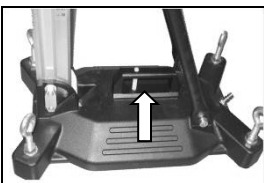

Remove the vacuum grip and the gasket of the base plate.

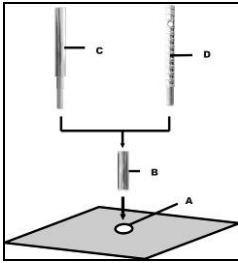

For brickwork, Rawl-Dowels must be used.

- Mark the position of the drill holes for the fastening on the surface to be drilled.
- Drill a hole (\varnothing 16) 50 mm deep (A), into which the dowel M12 (B) is to be placed; insert and secure the dowel with the doweling tool (C).
- Screw the quick action clamping screw (D) into the dowel.

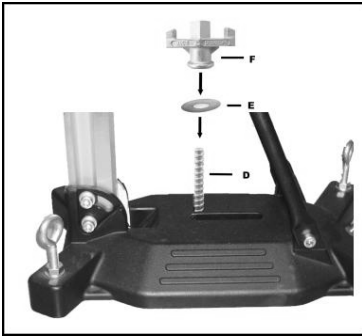

- Install the drill rig.
- Fix the washer (E) and finally the fastening nut (F) on the quick action clamping screw (D).
- Tighten the fastening nut (F) with a wrench SW 27.
- Before and after tightening the nut (F), the 4 adjustable screws have to be adjusted in order to adapt the rig to the surface.



Do check whether the drill rig is installed safely and firmly.

Fastening by means of quick action bracing unit

In order to brace the drill rig by means of the quick action bracing unit, the distance to the opposite wall must be between 1,7 m and 3 m.

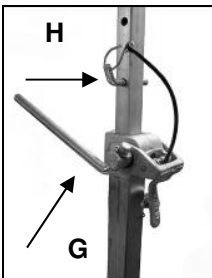

Position the drill rig. Position the quick action bracing unit as close as possible behind the support on the base of the rig. Fix the drill rig by turning the crank (G) clockwise. Secure in position by means of the appropriate bolt (H).

Attention! It is important, that the drill rig is firmly connected to the surface. If not fixed correctly, injuries to the operator or damages to the drilling unit may be caused. Uncontrolled movements during drilling will cause the drill bit to hit the surface to be drilled which may lead to a chipping of the segments. The drill bit might also tilt in the bore hole which consequently will damage it.

Fixing the Core Drill Motor



Wear protective gloves!

Caution! When mounting the machine, risk of squashing.

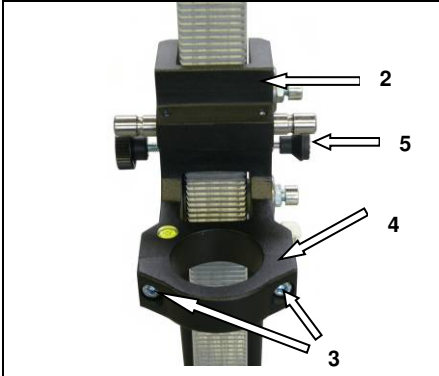

- Move the machine holder (2) upwards until the locking pin (5) locks in the column.
- Remove both Allen screws M8 (3) and take off the clamp (4).



- Put the core drill (M) on the carriage and close the clamp (4) by means of the Allen screws (3).

Operations

In order to operate the tool safely, please observe the following notes:

Details of the work area

- Keep the work area free of everything which could obstruct operations.
- Provide for adequate illumination of the work area.
- Adhere to the regulations concerning the power connection.
- Lay the power cable in such a way that any damage by the drill can be avoided.

- Make sure to always keep the work area in view and to be able to reach all necessary operating elements and safety installations.
- Keep other persons away from your work area in order to avoid accidents.

Space requirements for operating and maintenance

Whenever possible, keep a free space for operating and maintenance of about 2m around the drill position, so that you can work safely and have immediate access in case of a failure.

Drilling

Inclined drilling

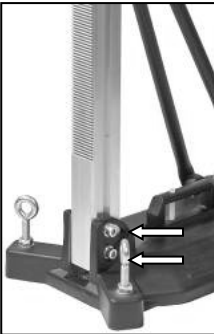

- Slacken the both screws at the base of the column. (see 1)
- Loosen the locking lever on the bracing. (see 2)
- Now turn the column until the desired angle.
- Tighten both screws and the locking lever again.

The scale on the toothed column makes adjusting the drilling angle easier.



At the beginning, drill very slowly, since the drill bit does only starts cutting with a fraction of the cut surface in the material. If you drill too fast or with too much pressure, the drill bit could get jammed.

In order to reach the max. drilling depth, you probably have to use an extension for the drill bit!

Demounting the Core Drill Unit



- Move the machine holder with the core drill upwards until it locks in the final top position.
- Remove the drill bit.

- Loosen the fastening nut (F) (see page 6)
- **While doing so, hold the drill rig firmly!**
- Remove the drill rig.
- Unscrew the quick action clamping screw (D) (see page 6).

Care and Maintenance

- Always keep the drill rig clean, especially the column with the tothing and the 4 sliding pieces in the machine holder.
- In order to allow the free movement of the pinion shaft, it should be slightly lubricated.
- In order to achieve a good performance of the drill rig, the 4 sliding pieces in the machine holder have to move along the column without slackness.
Attention:
- After every tenth drilling you should check if the sliding pieces have got loose-fitting due to drilling vibration.
- If the position should have changed, it can be readjusted as follows:

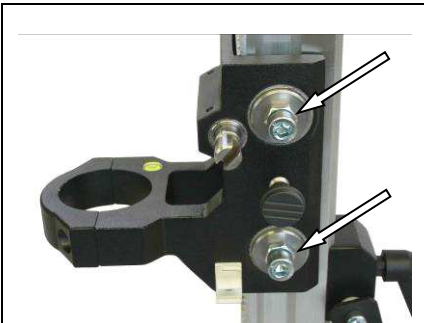

- Loosen the counter nut on the Allen screw by means of an jaw wrench SW 17
- Adjust the Allen screws and the position of the thrust piece to the column by means of a hex head wrench SW 8.
- Tighten the counter nut again and check whether the carriage moves easily on the column.

Behavior at Malfunction



Turn off the machine at malfunction and disconnect from the main supply. Operations on the electrical system of the machine can be executed by a specialist only.

Trouble Shooting

malfunction	possible cause	repair
Drill unit has too much play (vibration)	stand has been loose guidance has too much play thrust piece worn	adjust the wing nut adjust guidance (see above) replace the thrust piece

Warranty

According to our general terms of delivery for business dealings, suppliers have to provide to companies a warranty period of 12 months for redhibitory defects (to be documented by invoice or delivery note).

Damages due to natural wear, overstressing or improper handling are excluded from this warranty.

Damages due to material defects or production faults shall be eliminated free of charge by either repair or replacement.

Complaints will be accepted only if the tool is returned in non-dismantled condition to the manufacturer or an authorized Eibenstock service centre.



Declaration of Conformity

It is necessary that the machine (f. e. ETN 2001 P) used in this drill rig comply with the requirements which are described in the specifications of the drill rig (f. e. drilling diameter, fixture of the motor).

We declare that this unit has been designed in compliance with 2006/42/EC. This unit must not be put into service until it was established that the Power Tool to be connected to this unit is in compliance with 2006/42/EC (identified by the CE-marking on the Power Tool).

A handwritten signature in black ink, appearing to be 'L. Lässig', written over a horizontal line.

Vakuum Technik GmbH Eibenstock
Lothar Lässig
12.07.2022

Your distributor

Vakuum Technik GmbH
Am Steinbächel 3
08309 Eibenstock