



## TruTool N 700 (1A1)

Nibbler

---



---

# Table of contents

<b>1</b>	<b>Safety</b>	<b>2</b>
1.1	General safety information	2
1.2	Specific safety information for nibblers	2
1.3	Additional safety warnings	2
<b>2</b>	<b>Description</b>	<b>4</b>
2.1	Intended use	4
2.2	Technical data	5
2.3	Icons	5
2.4	Noise and vibration information	6
<b>3</b>	<b>Setting work</b>	<b>8</b>
3.1	Selecting a die	8
3.2	Select punch	9
3.3	Setting the penetration depth	10
3.4	Selecting and attaching a handle	11
3.5	Turning the motor handle	12
<b>4</b>	<b>Operation</b>	<b>14</b>
4.1	Working with TruTool N 700	14
4.2	Changing the cutting direction	15
4.3	Nibbling with a template	16
4.4	Producing interior cutouts	17
<b>5</b>	<b>Maintenance</b>	<b>18</b>
5.1	Replacing the tool	18
	Changing the punch	19
	Replacing the die and punch guide	20
5.2	Regrinding the punch	20
5.3	Changing the wearing plate	21
5.4	Changing cable connection	22
<b>6</b>	<b>Accessories and consumables</b>	<b>23</b>
6.1	Ordering consumables	23
<b>7</b>	<b>Appendix: Declaration of conformity, guarantee, replacement parts lists</b>	<b>25</b>

## 1. Safety

### 1.1 General safety information

#### WARNING

Read all the safety information and instructions.

- Failure to comply with the safety information and instructions can cause electric shock, burns and/or serious injury.
- Retain all the safety information and instructions for future use.

### 1.2 Specific safety information for nibblers

#### DANGER

**Electrical voltage! Risk of fatal injury due to electric shock!**

- Always keep the power cable behind the device and do not pull it over sharp edges.
- Do not perform any work that may cause the machine to come into contact with hidden power lines or its own cable. Contact with a live conductor can cause metallic machine parts to become live and can lead to an electric shock.

#### WARNING

**Risk of injury to hands.**

- Do not reach into the processing line with your hands. When switching off the motor, the drive will run down.
- Hold the machine with both hands.

#### WARNING

**Risk of injury from hot and sharp chips!**

**Chips exit the chip ejector at high speed.**

- Use a chip bag.

### 1.3 Additional safety warnings

#### Personal safety Note

**Do not let familiarity gained from frequent use of tools allow you to become complacent and ignore tool safety principles.**

A careless action can cause severe injury within a fraction of a second.



---

**Power tool use and care**    **Note**

**Keep handles and grasping surfaces dry, clean and free from oil and grease.**

Slippery handles and grasping surfaces do not allow for safe handling and control of the tool in unexpected situations.

## 2. Description

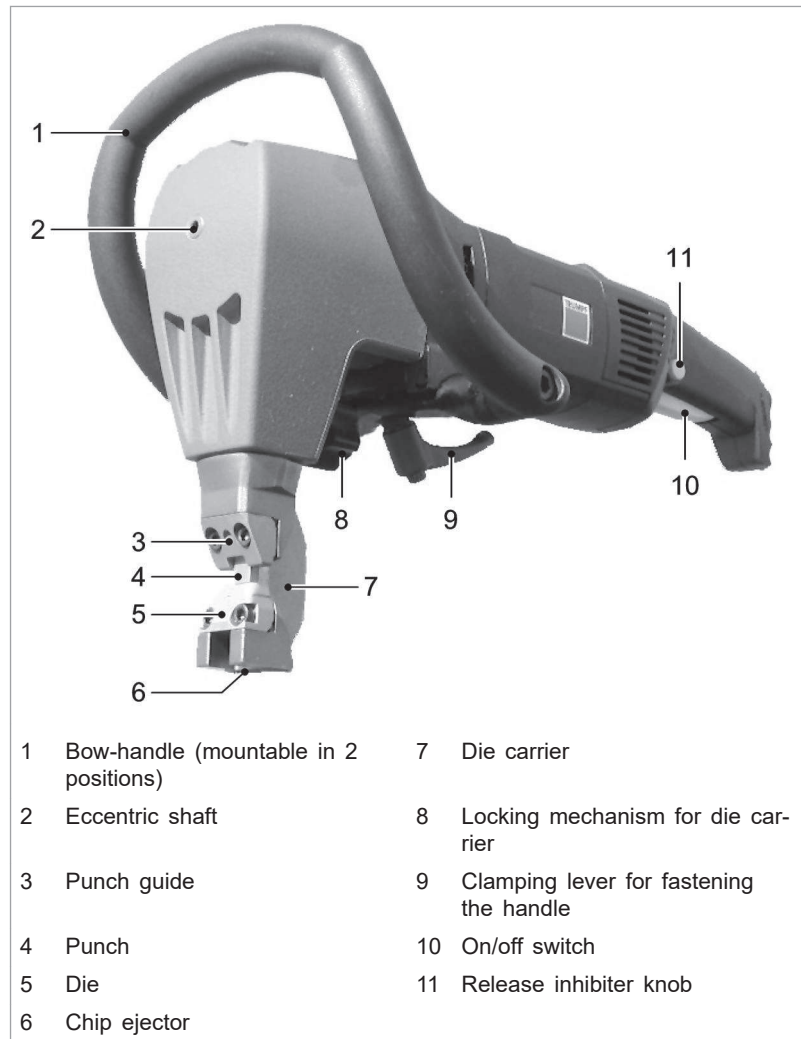

Nibbler TruTool N 700

Fig. 38379

### 2.1 Intended use





The TRUMPF Nibbler TruTool N 700 is an electric power tool for:

- The slitting of plate-shaped workpieces made of a punchable material such as steel, aluminum, non-ferrous heavy metals and plastic.
- The slitting of pipes and for machining of bent sheet profiles or bends; for example, for tanks, crash barrier, troughs, etc.
- The nibbling of straight or curved exterior and interior cut-outs.
- Nibbling along scribed lines or templates.

**Note**

The nibbling process produces cutting edges free of deformations.



**2.2 Technical data**

	Other countries			USA
<b>Voltage</b>	230 V 220 V (China)	120 V	110 V	120 V
<b>Frequency</b>	50/60 Hz	50/60 Hz	50 Hz	50/60 Hz
<b>Max. material thickness: Steel 400 N/mm<sup>2</sup></b>	7.0 mm	7.0 mm	7.0 mm	0.28 in
<b>Max. material thickness: Steel 600 N/mm<sup>2</sup></b>	5.0 mm	5.0 mm	5.0 mm	0.2 in
<b>Max. material thickness: Steel 800 N/mm<sup>2</sup></b>	3.5 mm	3.5 mm	3.5 mm	0.14 in
<b>Max. material thickness: Aluminum 250 N/mm<sup>2</sup></b>	10 mm	10 mm	10 mm	0.4 in
<b>Working Speed</b>	1.3 m/min	1.1 m/min	1.1 m/min	3.6 ft/min
<b>Nominal power consumption</b>	1600 W	1340 W	1500 W	1340 W
<b>Idle stroke rate</b>	440/min	470/min	440/min	470/min
<b>Weight</b>	8.3 kg	8.3 kg	8.3 kg	15.4 lbs
<b>Cutting track width</b>	11 mm	11 mm	11 mm	0.472 in
<b>Starting hole diameter for die</b>	60 mm	60 mm	60 mm	2.95 in
<b>Sheet profile 90° inside bending radius</b>	min. 10 mm	min. 10 mm	min. 10 mm	0.4 in
<b>Smallest radius for curved cut- outs</b>	135 mm	135 mm	135 mm	5.3 in
<b>Distance to the template</b>	11 mm	11 mm	11 mm	0.433 in
<b>Protective insulation</b>	II / 	II / 	II / 	II / 

Tab. 1

**2.3 Icons****Note**

The following symbols are important for reading and understanding the operator's manual. The correct interpretation of the symbols will help you operate the machine better and safer.

Icon	Name	Description
	Read operator's manual	Read the operator's manual and safety information in their entirety before starting up the machine. Closely follow the instructions given.
	Safety class II	Indicates a doubly insulated tool.
	Alternating current	Type or property of current
V	Volt	Voltage
A	Ampere	Current, current input
Hz	Hertz	Frequency (oscillations per second)
W	Watt	Power, power input
mm	Millimeters	Dimensions e.g.: material thickness, chamfer length
in	Inch	Dimensions e.g.: material thickness, chamfer length
$n_0$	Idle speed	Revolution speed without load
.../min	Revolutions/strokes per minute	Revolution speed, stroke rate per minute

Tab. 2

## 2.4 Noise and vibration information

### WARNING

**Noise emission value may be exceeded.**

- Wear hearing protection.

### WARNING

**The vibration emission value can be exceeded!**

- Select the right tools and exchange them in time in the event of wear.
- Have maintenance carried out by trained specialized technicians.
- Define additional safety measures for protecting the operator from the effect of vibrations (e. g. keep hands warm, organization of working procedures, machining at normal feed force).
- Depending on the operating conditions and state of the electric tool, the actual load might be higher or lower than the specified measured value.

### CAUTION

**Strong upward and downward movements (striking) due to unsuitable die.**

**Excessive tool wear and increasing strain on the machine.**

- Use a die which is as high as possible (keep clearance X in the following drawing as small as possible).

## Notes

- The specified vibration emission value was measured in accordance with a standardized testing procedure and can be used to compare one electric tool with another.
- The specified vibration emission value can also be applied for a provisional estimate of the vibration load.
- Times during which either the machine is switched off or running but not actually in use can considerably reduce the vibration load during the entire working period.
- Times during which the machine works independently and self-propelled do not have to be calculated.

Designation of measured value	Unit	Value according to EN 60745
Vibration emission value $a_h$ (vector sum of three directions)	m/s <sup>2</sup>	12
Uncertainty K for vibration emission value	m/s <sup>2</sup>	2.7
A-class acoustic pressure level $L_{pA}$ typically	dB (A)	89
A-class acoustic power level $L_{WA}$ typically	dB (A)	100
Uncertainty K for noise emission value	dB	3

Tab. 3

### 3. Setting work

#### 3.1 Selecting a die



**Strong upward and downward movements (striking) due to unsuitable die.**

**Excessive tool wear and increasing strain on the machine.**

- Use a die which is as high as possible (keep clearance X in the following drawing as small as possible).

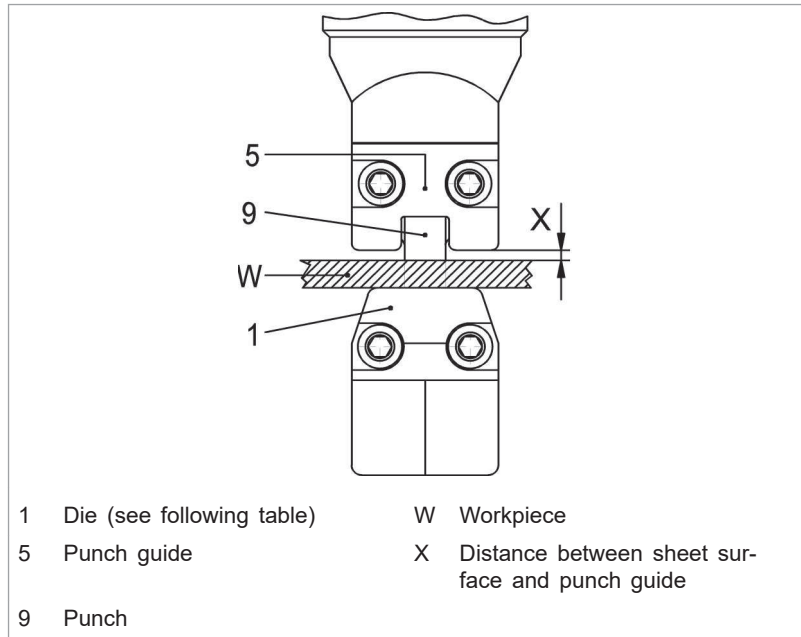

Fig. 16802

One of the following die types can be selected for processing according to the thickness, robustness and type of workpiece:

Material	Type of die 5	Type of die 7	Type of die P7
-			
	Mat. no. 0098723	Mat. no.: 0098722	Mat. no. 0098721
<b>Material thickness in mm, flat workpieces</b>			
Aluminum 250 N/mm <sup>2</sup>	-5	>5-7	>7-10

Material	Type of die 5	Type of die 7	Type of die P7
Mild steel 400 N/mm <sup>2</sup>	-5	>5-7	-
Stainless steel 600 N/mm <sup>2</sup>	-5	-	-
Stainless steel 800 N/mm <sup>2</sup>	-2.5	-	-
<b>Material thickness in mm, profiles with bends up to 90°</b>			
Aluminum 250 N/mm <sup>2</sup>	-3	>3-5	>5-7
Mild steel 400 N/mm <sup>2</sup>	-3	>3-5	>5-7
Stainless steel 600 N/mm <sup>2</sup>	-3	>3-5	-
Stainless steel 800 N/mm <sup>2</sup>	-2.5	-	-

Tab. 4

### 3.2 Select punch

There are 2 different punches available for machining sheets of various strength:

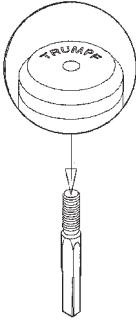
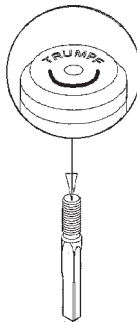
Components	Standard punch	Punch for high-tensile steels
		
Order number	104589	104590
Aluminum 250 N/mm <sup>2</sup>	x	-
Mild steel 400 N/mm <sup>2</sup>	x	-
Stainless steel 600 N/mm <sup>2</sup>	-	x
Stainless steel 800 N/mm <sup>2</sup>	-	x

Tab. 5

### 3.3 Setting the penetration depth

**Note**

A greater penetration depth causes less vibrations, but a greater effort is required when pushing the machine forward and the service life of the punch is reduced.

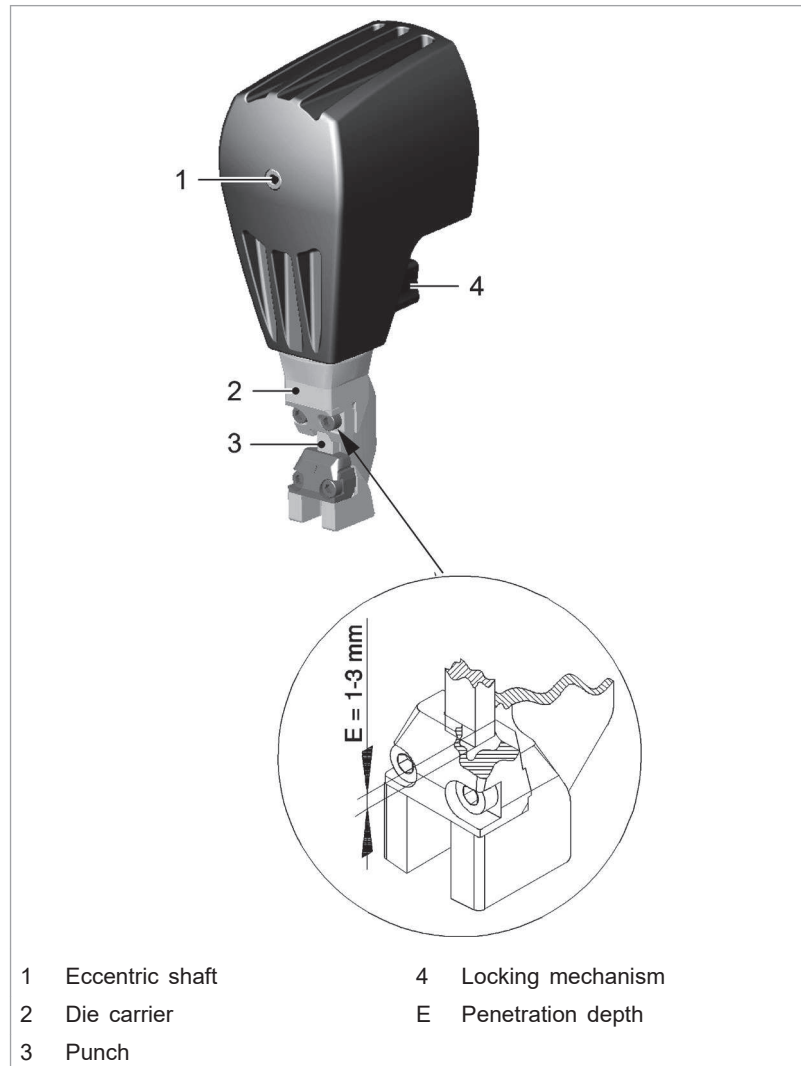

Fig. 38378

1. Rotate the eccentric shaft (1) until the punch (3) has reached its maximum penetration depth.
2. Open the locking mechanism (4).

**Note**

One rotation of 360° corresponds to a height adjustment of 1.75 mm.

3. Rotate the die carrier (2) by 360° as often as needed until the punch penetration depth of 1-3 mm has been achieved.
4. Close the locking mechanism (4).

### 3.4 Selecting and attaching a handle

The suitable handle can be chosen depending on the application.

Two types of handle are available:

- Bow-handle
- Compact handle

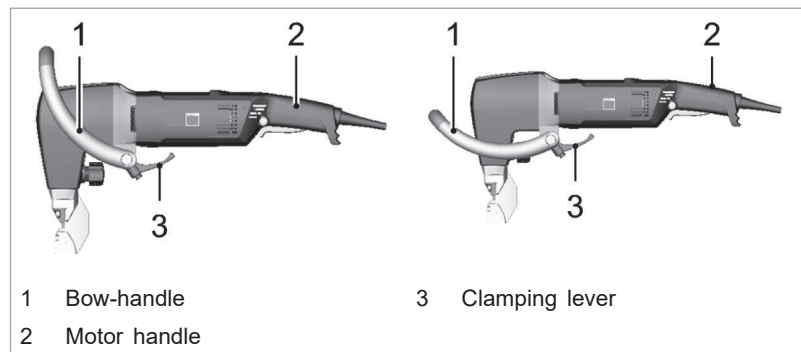

Bow-handle TruTool N 700

Fig. 54785

The bow-handle provides optimum handle positioning at all working heights. In combination with the motor handle, the weight of the machine is distributed over both handles.

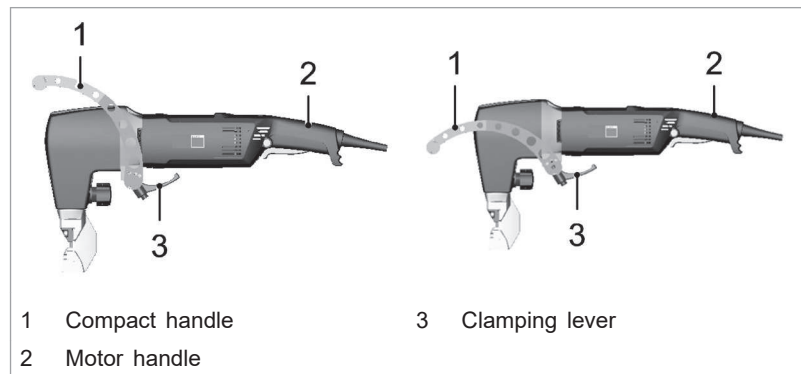

Compact handle TruTool N 700

Fig. 54786

The compact handle is developed for application in situations where space is limited (e.g. profile machining). Moreover it is made out of steel and is heat resistant.

**Attaching the handle**

1. Attach the handle to the machine without a tool, using the clamping lever (3) for assistance.

**Swiveling the handle****Note**

Each handle can be clamped in 2 positions using indexing.

2. Rotate the clamping lever (3) approx. 2 full turns.
3. Swivel the handle.
4. Fix the clamping lever (3) in place.

### 3.5 Turning the motor handle

**CAUTION****Damage to property due to dust being drawn into the ventilation slots**

- Rotate the motor handle so that no dust can be drawn in at the air suction point.

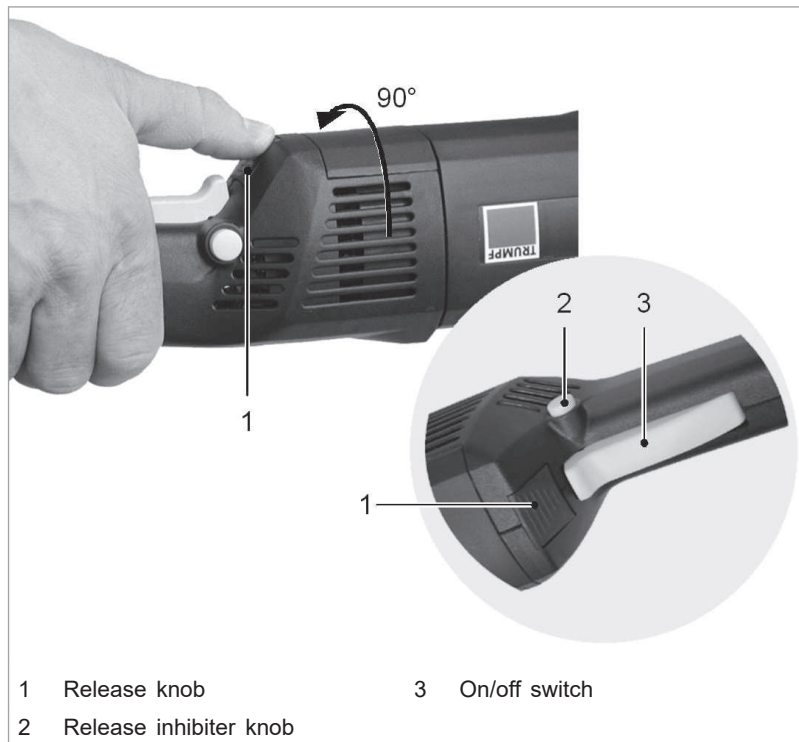

Fig. 38394

For applications where the machine is used tilted by 90°, it is favorable to rotate the handle accordingly.

1. Press the release button (1).
2. Turn the handle ( $\pm 90^\circ$ ).

- 
3. Release the release button (1).
  4. Lock the handle into place by turning it slightly.

## 4. Operation

### ⚠ WARNING

#### Damage to the machine due to improper handling.

- Make sure the machine is always in a stable position when operating it.
- Never touch the tool while the machine is running.
- Always operate the machine away from your body.
- Do not operate the machine above your head.

### ⚠ CAUTION

#### Damage to property due to excessively high line voltage!

#### Motor damage.

- Check the power supply voltage. The line voltage must correspond to the information on the nameplate of the machine.
- When using an extension cord that is longer than 5 m, it must have a conductor cross-section of at least 2.5 mm<sup>2</sup>.

In order to improve the cutting result and increase the service life of the punch, coat the cutting track with oil before machining the workpiece.

Material	Oil
Steel	Punching and nibbling oil for steel (0.5 l, order no. 0103387)
Aluminum	Punching and nibbling oil for aluminum (1 l, order no. 0125874)

Tab. 6

### 4.1 Working with TruTool N 700

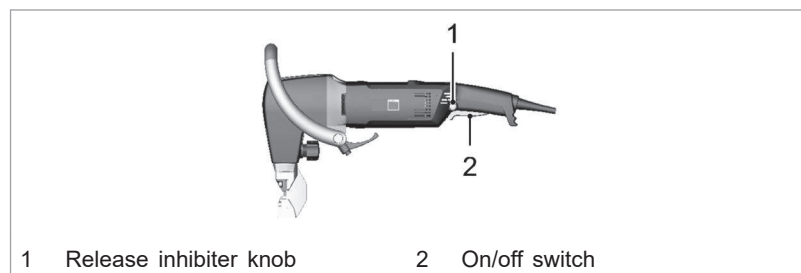

Fig. 38380

**Positioning the machine** 1. Put the machine in position in front of the tool.

**Switching on** 2. Either

- To switch the machine to continuous operation:

- Keep the release lock button (1) pressed and press the On/Off switch (2).
- Release On/Off switch (2).

The switch remains engaged. The motor is running.

**or**

- To switch the machine to instantaneous connection:
  - Keep the release lock button (1) pressed and press the On/Off switch (2).
  - Release the release lock button (1).

The motor is running.

- Processing the material**
3. Once the full speed has been reached: move the machine toward the workpiece.
  4. Process the desired cutting line.
  5. If the cutting track ends in the sheet: retract the running machine a few millimeters in the direction of the already free-cut cutting track.

- Switching off**
6. Immediately press the On/Off switch (2) and release.

## 4.2 Changing the cutting direction

The tool can be installed with an altered cutting direction in confined space conditions.

- To cut profiles: install the tool rotated by 90° to the right or left.
- To nibble to the rear: install the tool rotated by 180° to the right or left.

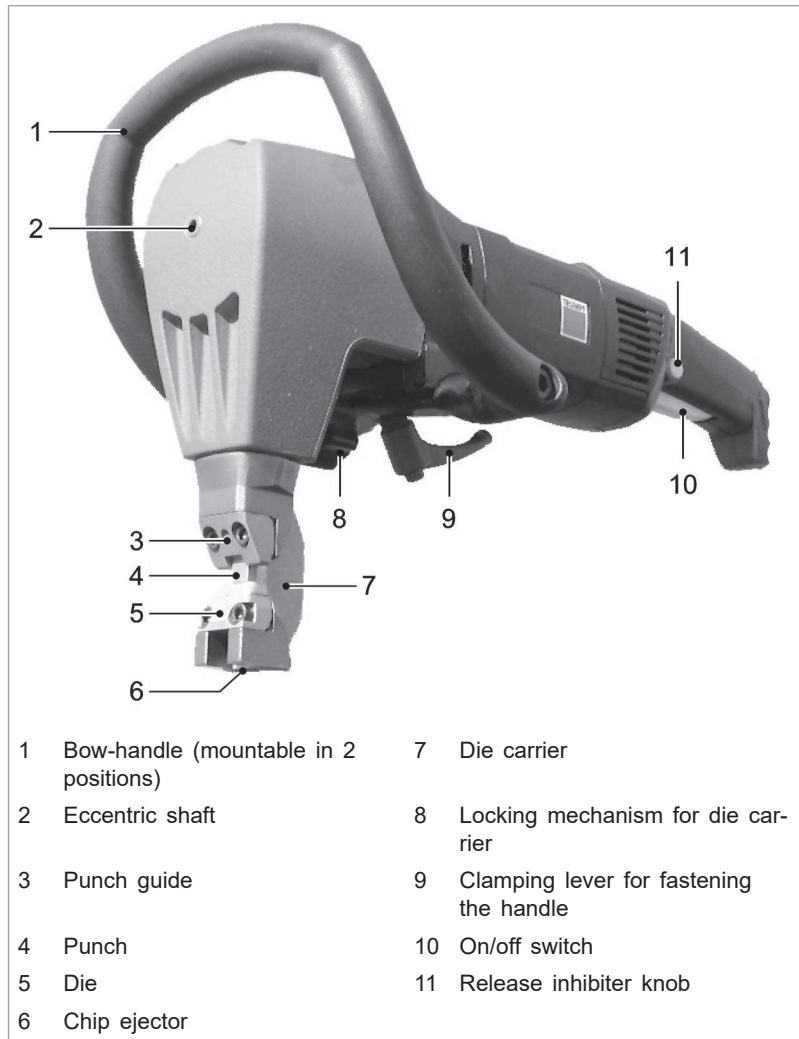

Nibbler TruTool N 700

Fig. 38379

1. Open the locking mechanism (8).
2. Rotate the die holder (7) into the desired direction.
3. Close the locking mechanism (8).
4. Check the plunging depth of the punch.

### 4.3 Nibbling with a template

The following requirements must be met when nibbling with templates:

- The template must be at least 5 mm thick.
- There must be a clearance of 11 mm between the contour of the template and the contour to be nibbled out.

- 
- The nibbler must be guided in such a way that the outer edge of the punch guide (5) always remains up against the template.
  - Observe a minimum radius of 135 mm.

#### **4.4 Producing interior cutouts**

- Produce start bore with at least a 60 mm diameter.

## 5. Maintenance

### DANGER

**Electrical voltage! Risk of fatal injury due to electric shock.**

- Remove the plug from the plug socket before undertaking any maintenance work on the machine.

### WARNING

**Risk of injury due to incorrect repair work**

**Machine does not work properly.**

- Maintenance may be carried out by trained specialist technicians only.

### CAUTION

**Damage to property caused by blunt tools!**

**Machine overload.**

- Check the cutting edge of the cutting tool every hour for wear or in the event of poor cutting behavior or poor work result. Sharp cutting tool produces good cutting performance and protects the machine.
- Change the cutting tool in a timely manner.

Maintenance point	Procedure and interval	Recommended lubricants	Lubricant order number
Punch, die and wear parts	Check every hour	-	-
Punch	Regrind/replace as needed.	-	-
Ventilation slots/grids	Clean as needed	-	-
Die	Change as needed	-	-
Wearing plate	Change as needed	-	-
Punches and die holders	For tool change	Lubricating grease "G1"	0344969
Gearbox and gear head	Every 300 operating hours, have a trained specialist relubricate or replace the lubricating grease.	Lubricating grease "G1"	0139440

Maintenance positions and maintenance intervals

Tab. 7

### 5.1 Replacing the tool

#### Note

If the punch or die is blunt or the punch cannot be reground, the tools must be replaced.

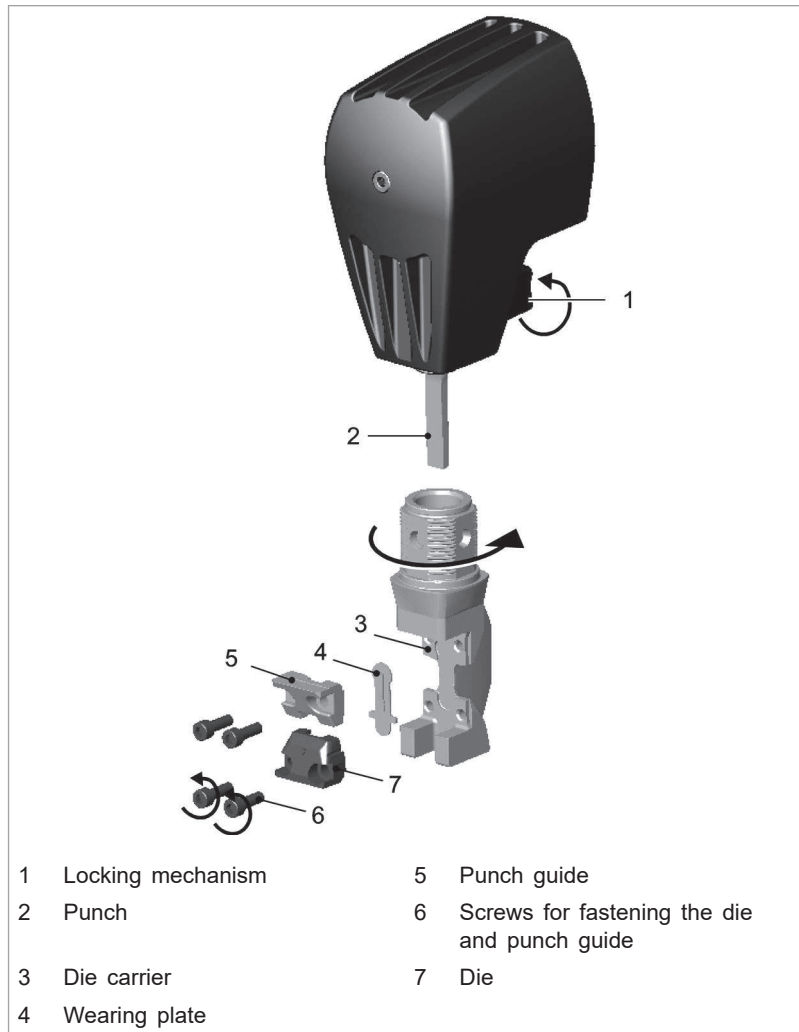

Fig. 38381

## Changing the punch

1. Release the locking mechanism (1).
2. Rotate the die holder (3) by 45°.
3. Pull the die holder (3) downward and out.
4. Screw out the punch (2).

### Note

To grease, use lubricating grease "G1" (order number 139440).

5. Apply a thin film of grease on the square part of the punch and die holder bore.
6. Screw in the punch (2).
7. Align the punch to 45°.

8. Check the penetration depth of the punch with the setting gauge (order number 1411767).
9. Close the locking mechanism (1).

## Replacing the die and punch guide

1. Unscrew screws (6).
2. Clean the support areas on the die holder (3).
3. Clean the replacement parts if necessary.

### Note

To grease, use lubricating grease "G1" (order number 139440).

4. Lubricate the guide surfaces of the punch guide.

### Note

Only use **new** original screws at every change (order number 2596792).

5. Firmly tighten screws (6) (tightening torque 20 Nm).

## 5.2 Regrinding the punch

### Notes

- Dies cannot be reground.
- Use only original spare parts from TRUMPF.
- The punch can be reground a total of approx. 10 mm. Note that the minimum length is 89 mm: shorter punches must be replaced (risk of collision).



---

The wearing plate must be replaced when:

- The raised part (1) is worn down.
- The depression (2) is no longer visible.

## 5.4 Changing cable connection

If the power cable is to be replaced, it should be procured from the manufacturer or an authorized dealer to avoid safety hazards.

### Note

For TRUMPF service addresses, see [www.trumpf-power-tools.com](http://www.trumpf-power-tools.com).

## 6. Accessories and consumables

-	Scope of delivery	Consumables	Accessories	Order number
Punch (standard)	x	x	-	0104589
Punch for high-strength sheets	-	x	x	0104590
Die5	-	x	x	0098723
Die7	x	x	-	0098722
Die P7	-	x	x	0098721
Wearing plate	x	x	-	0119173
Bow-handle cpl.	x	-	-	1279590
Compact handle cpl.	x	-	-	1279618
Case	x	-	-	1279611
Punching and nibbling oil for steel (0.5 l)	-	-	x	0103387
Punching and nibbling oil for aluminum (1 l)	-	-	x	0125874
Allen key DIN 911-5	x	-	-	2568044
Lubricating grease "G1" tube (25 g)	x	-	-	0344969
Lubricating grease "G1" can (900 g)	-	-	x	0139440
Safety information, other countries	x	-	-	0125699
Safety information (red document), USA	x	-	-	1239438
Chip bag	-	-	x	0109275

Tab. 8

### 6.1 Ordering consumables

#### Note

The following data must be specified in order to ensure that parts are delivered correctly and without delay.

1. Specify the order number.
2. Enter further order data:
  - Voltage data
  - Quantity
  - Machine type
3. Specify the complete shipping information:
  - Correct address.
  - Desired delivery type (e.g. air mail, courier, express mail, ordinary freight, parcel post).

#### Note

For TRUMPF service addresses, see [www.trumpf-powertools.com](http://www.trumpf-powertools.com).

- 
4. Send the order to the TRUMPF representative office.

---

**7. Appendix: Declaration of conformity,  
guarantee, replacement parts lists**

