



EIBENSTOCK

Elektrowerkzeuge



Original Instructions



EBS 1802.1 U



Important Safety Instructions

Important instructions and warning notices are allegorized on the machine by means of symbols:



Before you start working, read the operating instructions of the machine.



Work concentrated and carefully. Keep your work-place clean and avoid dangerous situations.



In order to protect the user, take precautions.

During work you should wear ear protectors, goggles, dust mask, protective gloves and sturdy work clothes!



Use ear protection



Wear safety goggles



Wear a dust mask



Wear protective gloves

Warning notices



Warning of general danger



Warning of dangerous voltage



Warning of hot surface



Danger of being ripped or cut

Specifications

Concrete Grinder EBS 1802.1 U

Rated voltage	120 V ~
Rated current	15 A
Order No.	06349000

Frequency:	50 / 60 Hz
Rated speed:	10 000 rpm
Max. disc diameter:	5"
Spindle:	7/8"
Protection class:	II
Degree of protection:	IP 20
Net weight:	12 lbs
Interference suppression:	EN 55014 and EN 61000

Available special accessories:

Item	Order No.
Diamond Grinding Wheel	
Type	Colour
Concrete standard	gold, sand
Concrete premium	gold, sand
Screed	yellow
Rapid K	blue
PCD	black
Brush rim (2-part)	
Floor guiding device	
Industrial Vacuum Cleaner DSS 35 M iP	

Content of Delivery

Concrete grinder with diamond grinding wheel (concrete), tool kit and operating instructions in a metal case

Application for Indented Purpose

The concrete grinder is indented for professional use.

With an appropriate grinding wheel, the tool may be used for smoothing rough concrete, removing mould seams, residual mud, joint fillers and tile adhesives.

Only use grinding wheels recommended by the manufacturer. These have a small weight and a high concentricity. Using other grinding wheels can cause an overload of the machine or damage of the bearings and danger to the user.

Safety Instructions



Safe work with the machine is only possible if you read this operating instruction and follow the instructions contained strictly.

Additionally, the general safety instructions of the leaflet supplied with the tool must be observed. Prior to the first use, the user should absolve a practical training



If the mains cable gets damaged or cut during the use, do not touch it, but instantly pull the plug out of the socket. Never use the tool with damaged mains cable.



The tool must neither be wet nor used in humid environment.

- Do not use the tool in an environment with danger of explosion.
- Do not drill into asbestos-containing materials.
- Modifications of the tool are prohibited.
- Never use the machine without dust guard.
Use machine with partly removed dust guard in corners only.
For other applications the dust guard must always be closed.
- Always check the tool, cable and plug before use and plug before use.
Have damages only repaired by specialists.
- Insert the plug into the socket only when the tool switch is off.
- When you work outside, the machine has to be used with a fault-current circuit breaker with max. 30 mA.
- The machine should only work under supervision of somebody.
Plug and switch the machine off if it is not under supervision, in case of putting up and stripping down the machine, in case of voltage drop or when fixing or mounting an accessory.
- Switch the machine off if it stops for whatever reason. You avoid that it starts suddenly and not under supervision.
- Don't use the machine if a part of the housing is damaged or in case of damages on the switch, the cable or plug.
- Pay attention that the speed indicated on the grinding wheel meets or is higher than the max. speed indicated on the machine.
- Grinding wheels have to be stored and used carefully according to the instructions of the producer.
- Check the accessories before use. Do not use any products which are broken, cracked or damaged in another way.
- Before use, make sure that the tool is correctly fixed and fastened.
Let it run idle for about 30 seconds in a safe position. If considerable vibrations occur or if other defects are recognised, switch off immediately.

- Always lead the mains and extension cable as well as the extraction hose to the back away from the machine.
- Power tools have to be inspected by a specialist in regular intervals.
- Never carry the machine at its cable.
- Do not touch rotating parts.
- Persons under 16 years of age are not allowed to use the tool.
- **During use, the operator and other persons standing nearby have to wear suitable ear protectors, a dust mask and protection goggles.**



- Make sure that persons in the work space are not endangered by particles flying around.
- Keep the handles dry, clean and free of oil and grease.
- **During operation, always hold the tool with both hands.**
- **Attention! The tool still runs for a little while after the machine was switched off.**

For further safety instructions, please refer to the enclosure!



Electrical Connection

Before starting the machine check the correspondence between voltage and frequency according to the data mentioned on the identification plate. Voltage differences from + 6 % and – 10 % are allowed.

The grinder is made in protection class II.

Only use extension cables with a sufficient cross-section. A cross-section which is too small could cause a considerable drop in performance and an overheating of machine and cable.

The tool includes a start-up speed limiter to prevent fast expulsion fuses from unintended responding.

Recommended extension cord sizes for use with portable electric tools:

Length of Cord in Feet										
110 V	25 Ft.	50 Ft.	100 Ft.	150 Ft.	200 Ft.	250 Ft.	300 Ft.	400 Ft.	500 Ft.	
Nameplate Ampere Rating	0-2	18	18	18	16	16	14	14	12	12
	2-3	18	18	16	14	14	12	12	10	10
	3-4	18	18	16	14	12	12	10	10	8
	4-5	18	18	14	12	12	10	10	8	8
	5-6	18	16	14	12	10	10	8	8	6
	6-8	18	16	12	10	10	8	6	6	6
	8-10	18	14	12	10	8	8	6	6	4
	10-12	16	14	10	8	8	6	6	4	4
	12-14	16	12	10	8	6	6	6	4	2
	14-16	16	12	10	8	6	6	4	4	2
	16-18	14	12	8	8	6	4	4	2	2
	18-20	14	12	8	6	6	4	4	2	2

Switching on and off

Short-Time Operation

Switching-on: press the on/off switch

Switching-off: release the on/off switch

Permanent Operation

Switching-on: press the on/off switch and, keeping it pressed, engage the lock-on button

Switching-off: press the on/off switch and release it again

Attention!



In case of every stop of the machine or a power cut, the lock-on button has to be released immediately by pressing the ON/OFF switch. So you can avoid an unintentional restart of the machine (physical hazard).

Overload Protection

In order to protect the motor, the **EBS 1802.1 U** is equipped with an overload protection. This one is positioned on the bag side of the motor housing (left).

In case of an overload due to a too high grinding pressure, the machine reacts by cutting off.

After the cut-off, when having pressed the overcurrent switch and having switched the machine on again, you can continue working.

Changing the Diamond Grinding Wheel



Attention!

The grinding wheel might heat up enormously during operation. You could burn your hands or get cut or ripped by the segments. Therefore, always use protective gloves when changing the grinding wheel.

Before any work on the tool, disconnect the plug from the mains!

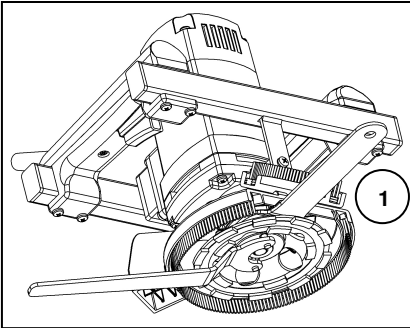

First of all, the hood segment has to be opened.

Now you can hold up the driving disc between gearbox and grinding wheel by using a jaw wrench 32 (1). Use the face spanner (2) to unscrew the driving nut. Then remove the mounted grinding wheel respectively mount the new one. The assembly works the other way round!

Let the machine run for a short period of time and in a safe position. If the machine does not run easily, stop working immediately.

Use only original accessory!

Application of Grinding Wheels

Type	Max. Rated Speed	Colour	Application
Diamond Grinding Wheel			
Concrete	10,000 rpm	gold, sand	for finishing and facing concrete, brick, limesandstone, basalt, sandstone
Screed	10,000 rpm	yellow	for finishing fresh and green concrete, screed, lime mortar plaster, mortar, plaster, soft limestone
Rapid K	10,000 rpm	blue	for removing epoxy resin and two-component coatings

PCD	10,000 rpm	black	universal applicable - for example: concrete, screed, adhesive remnants and coatings - grinding wheel with monobloc diamonds
-----	------------	-------	--

Dust Extraction

Dust which occurs during your work is hazardous to health. That is why the concrete grinder must be used with a vacuum cleaner, and a dust mask has to be worn. The suitable Wet/Dry Vacuum Cleaner DSS 35 M iP are available as accessory. It can directly be attached to the connection on the dust hood.

Changing the brush rim

If the length of the brushes is – due to wear - smaller than 5 mm (extreme formation of dust during grinding), the brush rim has to be replaced completely.

Therefore, remove the three fixing screws of the firm part of the dust guard and the two fixing screws of the detachable part. Pull out the worn brush rim and replace it by a new one. Pay attention that the fastening holes in the brush rim and the holes of the dust hood have the same same position. Screw both parts together.

Instruction for Use

Switch the machine on and put it carefully on the surface you want to work on. Hold the tool with both hands and work with circular or linear movements.

For best working results: Don't put too much pressure on the surface you want to work on.

For grinding works right into edges of the wall one segment of the dust guard can be opened. This allows grinding on surfaces which are usually hard to reach.

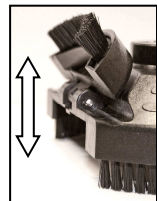

Attention!

All other grinding works have to be done with the complete dust guard.

Function and Assembly of the Floor Guiding Device



Attention!

Before any work on the tool, disconnect the plug from the mains!

For grinding works on larger floors, a floor guiding device is available as accessory. It allows a more comfortable handling of the concrete grinder.

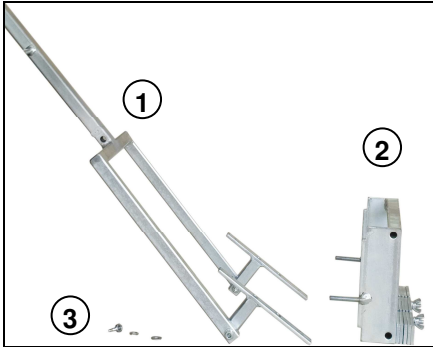

- ① device with holder
- ② top frame with weights
- ③ disc, spring ring, wing nut

Assembly

Lock the ON/OFF switch of the concrete grinder.

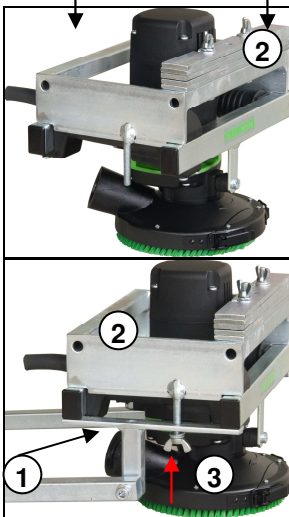

Put the top frame with the weights ② on the frame handle of the machine.

Then put the device with the holder ① under the frame handle and fix it with disc, spring ring and wing nut ③ on the top frame ②.



Wind the line cord of the tool on the holder meant for this purpose. **Make sure that the switch of the floor guiding device is not pressed or locked.** Plug the grinder in the socket of the floor guiding device. Lead the hose of the vacuum cleaner above the floor guiding device, connect it with the grinder. The clamp will avoid a slipping of the hose.

Care and Maintenance



Before the beginning of maintenance or repair works you have to disconnect the plug from the mains.

Repairs may be executed only by appropriately qualified and experienced personnel. After every repair the machine has to be inspected by an electric specialist. Due to its design, the machine needs a minimum of care and maintenance. However, the following points always have to be observed:

- Always keep the power tool and the ventilation slots clean.
- During work, please pay attention that no particles get inside the machine.
- In case of failure, a repair has to be carried out by an authorised service workshop.

Environmental Protection



Raw material recycling instead of waste disposal

To avoid damages on transportation, the power tool has to be delivered in a sturdy packing. Packaging as well as unit and accessories are made of recyclable materials and can be disposed accordingly.

The tool's plastic components are marked according to their material, which makes it possible to remove environmental friendly and differentiated because of available collection facilities.

Only for EU countries

Do not dispose of electric tools together with household waste material!

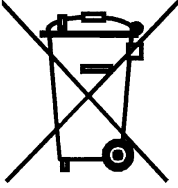

In observance of the European Directive 2012/19/EU on waste electrical and electronic equipment and its implementation in accordance with national law, electric tools that have reached the end of their life must be collected separately and returned to an environmentally compatible recycling facility.

Noise Emission / Vibration

The indication of noise emission is measured according to DIN 45 635, part 21. The level of acoustic pressure on the work place could exceed 85 dB (A); in this case protection measures must be taken.



Wear ear protectors!

The typical hand-arm vibration is below 2.5 m/s².
Measured values determined according to EN 60 745.

The declared vibration emission level represents the main applications of the tool. However if the tool is used for different applications, with different accessories or poorly maintained, the vibration emission may differ. This may significantly increase the exposure level over the total working period.

An estimation of the level of exposure to vibration should also take into account the times when the tool is switched off or when it is running but not actually doing the job. This may significantly reduce the exposure level over the total working period.

Identify additional safety measures to protect the operator from the effects of vibration such as: maintain the tool and the accessories, keep the hands warm, organisation of work patterns.

Dust protection

Dust from material such as paint containing lead, some wood species, minerals and metal may be harmful. Contact with or inhalation of the dust may cause allergic reactions and/or respiratory diseases to the operator or bystanders.

Certain kinds of dust are classified as carcinogenic such as oak and beech dust especially in conjunction with additives for wood conditioning (chromate, wood preservative). Material containing asbestos must only be treated by specialists.

- Where the use of a dust extraction device is possible it shall be used.
- To achieve a high level of dust collection, use industrial vacuum cleaner DSS 35 M iP for wood and/or minerals together with this tool.
- The work place must be well ventilated.
- The use of a dust mask of filter class P2 is recommended.

Warranty

According to our general terms of delivery for business dealings, suppliers have to provide to companies a warranty period of 12 months for redhibitory defects (to be documented by invoice or delivery note).

Damages due to natural wear, oversteering or improper handling are excluded from this warranty.

Damages due to material defects or production faults shall be eliminated free of charge by either repair or replacement.

Complaints will be accepted only if the tool is returned in non-dismantled condition to the manufacturer or an authorized Eibenstock service centre.

EU - Declaration of Conformity

We declare under our sole responsibility that the product described under "Technical Data" is in conformity with the following standards or standardization documents:

EN 60 745

according to the provisions of the directives 2011/65/EU, 2014/30/EU, 2006/42/EG

Technical file (2006/42/EC) at:

Elektrowerkzeuge GmbH Eibenstock
Auersbergstraße 10
D – 08309 Eibenstock



Lothar Lässig
General Manager



Frank Markert
Head of Engineering

13.07.2022

GB - Declaration of Conformity

We declare under our sole responsibility that the product described under "Technical Data" is in conformity with the following standards or standardization documents:

BS EN 60 745

according to the provisions of the directives 2011/65/EU, 2014/30/EU, 2006/42/EG

Technical file (2006/42/EC) at:

Elektrowerkzeuge GmbH Eibenstock
Auersbergstraße 10
D – 08309 Eibenstock



Lothar Lässig
General Manager

13.07.2022



Frank Markert
Head of Engineering

Your distributor

Elektrowerkzeuge GmbH Eibenstock
Auersbergstraße 10
D – 08309 Eibenstock
www.eibenstock.com