

Clamp | Part No. 2 1330 8500

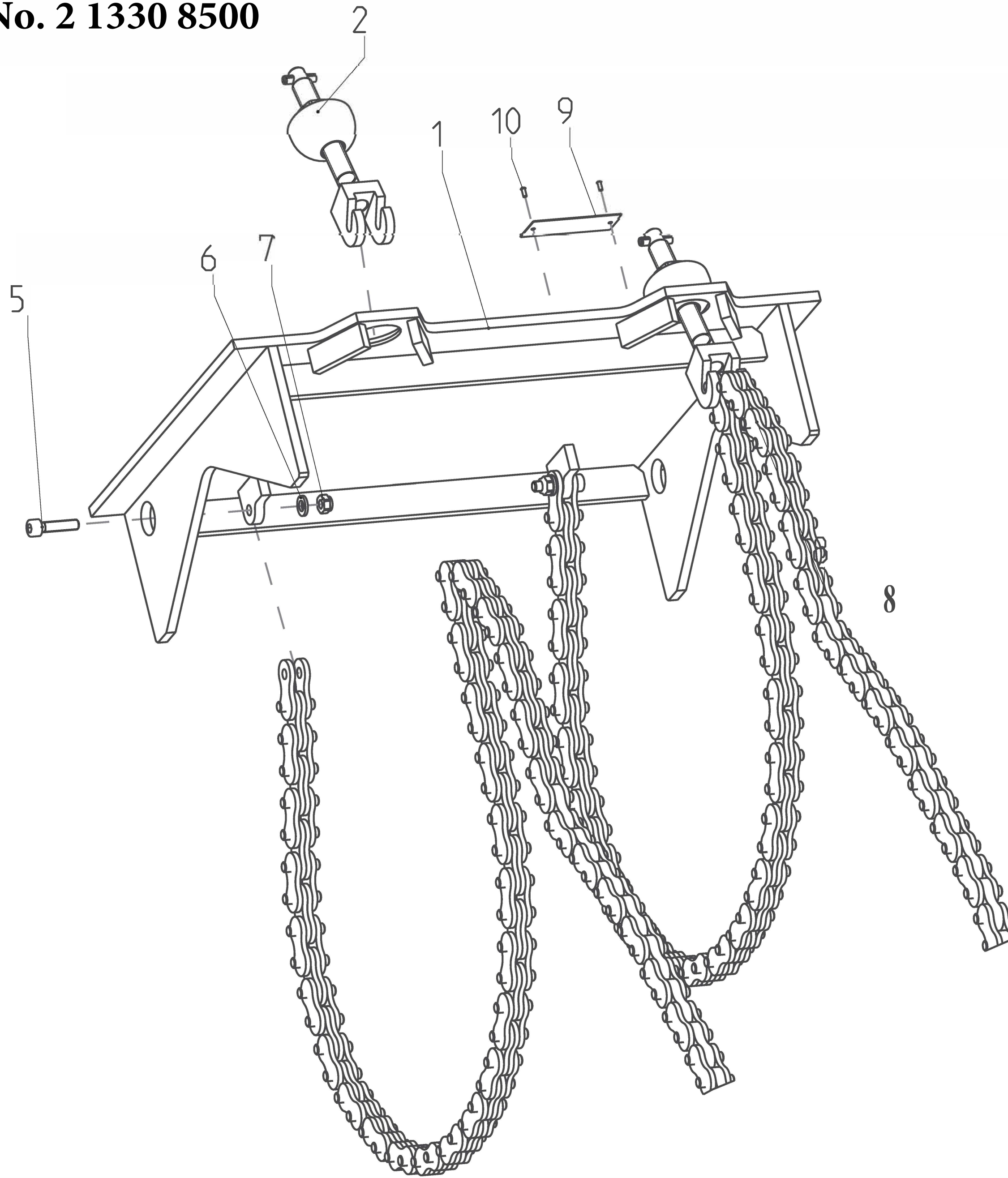

SPITZNAS
CUSTOMIZED POWER SOLUTIONS



Copying of this document, and giving it to others, and the communication of the contents hereof, are forbidden without express authority. Offenders are liable to the payment of damages. All rights are reserved in the event of the grant of a patent or the registration of a utility model or design.

„Weitergabe sowie Vervielfältigung dieser Unterlage, Verwertung und Mitteilung ihres Inhalts sind gestattet, soweit nicht ausdrücklich zugestanden. Zuwiderhandlungen verpflichten zu Schadenersatz. Alle Rechte für den Fall der Patenterteilung oder Gebrauchsmuster-Eintragung vorbehalten.“

Werkstoffdickeiten ohne Angabe nach DIN 5784
 Außenkante ± 0.5
 Innenkante ± 0.3
 Außenkante ± 0.5
 Innenkante ± 0.3

Oberflächen nach ISO 1302		Gewicht in kg		12,676		
Gußgüte		Güteklasse		GTA 15/5		
Allgemeintoleranzen für Schweißkonstruktion		DIN EN ISO 13920-B		brüniert		
ISO-Passung DIN 7157	Abmaße in µm	Toler.-klass.				Werkstoff/Rohteil:
		Abmaße in mm				
		0,5	6	30	120	ISO/128 Methode E
		6	30	120	400	
		mittel $\pm 0,1$ $\pm 0,2$ $\pm 0,3$ $\pm 0,5$				Ersatzwerkstoff:
		Datum Name				
		Bearb. 22.05.24 Forchert				Benennung:
		Gepr. 22.05.24 Witt				
		Norm.				Sach- und Zchn.-Nr.
		2 035/24 22.05. Forch				
		1 027/16 22.08. Forch				Blatt 3/3
		Änderungs- Tag Name Serien- mittelung -Nr.				
SPITZNAS CUSTOMIZED POWER SOLUTIONS		2 1330 8500		Format		Massstab 1:2
Nachschneidwerkzeuge GmbH - Fellnerstr. 4 - 42555 Rülberl-Germany		A2				



Note	Position	St.	Part No.	Designation
Parts list for Part No. 2 1330 8500				
	1	1	2 1330 8510	Base plate complete
	2	2	9 1150 9490	Fork Screw cpl.
	5	2	9 1110 4040	Cylinder Screw M6x25 DIN 912 8.8
	6	2	9 3302 0020	Disc A 6. DIN-125
	7	2	9 1210 0030	Hexagon nut M6 DIN 985-8
	8	2	51201 9020	Tension chain
	9	1	9 3101 0080	Stainless steel nameplate
	10	2	9 1628 0040	Half-round notch nail 2x5 DIN 1476 stainless steel

Distributed By:



22 Harbor Ave, Norwalk CT 06850

4330 Center St, Deer Park, TX 77536

Phone 800-700-5919 • 203-853-9522

info@csunitec.com • www.csunitec.com