



SPITZNAS
CUSTOMIZED POWER SOLUTIONS

Pneumatic Sabre Saw

Type 5 1217 0020

ATEX Tool



Illustration can differ from the original

Repair Manual and Spare Parts List

Repair

Disassembly

Disassembly and re-assembly should be done according to the sectional drawing only. Observe the safety instructions of the operation and maintenance manual.

Gearbox head

Remove protective cover item 1. Loosen socket head screws item 2 and remove gear part 2 item 9. Pull out of gear part 1 item 28 inner parts such as: roller guide item 120 with bearings, roller holder item 124 with bearings, bevel gear item 24, axial thrust bearing item 25 and axial disc item 26. Remove supporting shoe item 15 from gear part 2 item 9. Undo screws item 6 and take out gate item 7 and sealing item 8. Screw out spring pressure piece item 14, pull out lift rod item 5, remove cylinder pin item 10, needle bearing item 11 and sliding roller item 17.

Motor

Undo screws item 31 and draw off complete handle. Screw out motor cover item 17 and take out o-ring item 16. Knock out inner motor parts. Press out all inner parts of the motor. By tapping with a rubber mallet on end plate item 3, cylinder bushing item 7 can be removed. Draw off end plate item 3 with bearing item 4 and spacer item 6 from rotor item 10, remove cylinder bushing item 7, as well as vanes item 11. Separate pinion item 20 from rotor and remove end plate item 12 with bearing from rotor. Remove spacer item 15 from the bearing seat. Pull sound absorber item 2 out of motor housing item 1.

Handle

Screw out nipple item 29 with reducing nipple. Take out compression spring item 28, steel ball item 27, pin item 25 and sealing ring item 26. Knock out double notched taper pin item 24 and remove valve trigger item 23. Replace bushing item 32, guide sleeve item 33, pressure spring item 34 and locking slide item 35 only when defective. Bushing item 32 and guide sleeve item 33 are glued in and can be loosened only after heating.

Re-assembly

Re-assembly is performed basically the same as disassembly, but in reverse order. Mind especially the following items!

Handle

Control function after assembly. Look out for leaks and correct pin guide on the valve trigger. Check the locking bolt.

Motor

If bearings items 4 and 13 in the end plates items 3 and 12 were replaced, the spacing of the motor has to be redone. For that, new spacers items 6 and 15 are used. Press bearings in the end plates backlash-free in direction to snap ring in order to find out dimension of spacer. The end play between rotor and end plates should be approx. 0.04 mm per side, to ensure free running of the rotor.

Make functional gauging of motor with handle by checking free speed (approx. 15,000 rpm at an operating pressure of 6 bar).

Gearbox head

Build-in lift rod item 5 in correct position. Check the complete assembled bevel gear item 24 with bearings and bolts for easy running. Attach roller holder item 124 completely.

Test roller guide for easy movement. Screw together gear part 1 and gear part 2 and pull over protective cover. Screw components „Motor with Handle “ and „ Gearbox head“.

Fill the gear with grease, e.g. Calypsol-D8024 (approx. 80 g).

After completion of re-assembly make following functional gauging: Cutting capacity, Power, start reaction

Replacement of Vanes

For replacing the main wear parts (the vanes) proceed as follows:
Disconnect air hose from handle. After loosening screws item 27 of gearbox, take off motor with handle. Remove pinion item 20 from rotor journal. Screw out motor cover item 17. Draw out rotor item 10 with end plate item 12 and vanes item 11. Tapping with a rubber mallet onto edge of the motor housing item 1 is helpful. Doing that, also cylinder bushing item 7 with rear end plate item 3 can be drawn out.

CAUTION! Do not cant/ Never use force!

Change vanes item 11, clean rotor slots, check surfaces and smooth them, if necessary. Push cylinder bushing item 7 into housing. Take care for correct position. Put in spacers item 6 again, looking for that the inner chamfer as well as spacer item 15 point to the rotor. Insert rotor item 10 with the new vanes item 11 and spacer item 15. Install end plate item 12 with bearing. Put in O-ring item 16 and fasten motor cover with screws. Now rotor has to be turned easily. If not, light tapping with a rubber mallet straight or lateral on motor housing is helpful to put the rotor in free-wheel position. Thereupon mount the pinion item 20 and screw on gearbox. Connect air hose and perform functional gauging.

Replace wear parts – in particular the vanes – when necessary.
Vanes are considered worn, if their width is less than 9.5 mm.

Vane 5 1216 1050

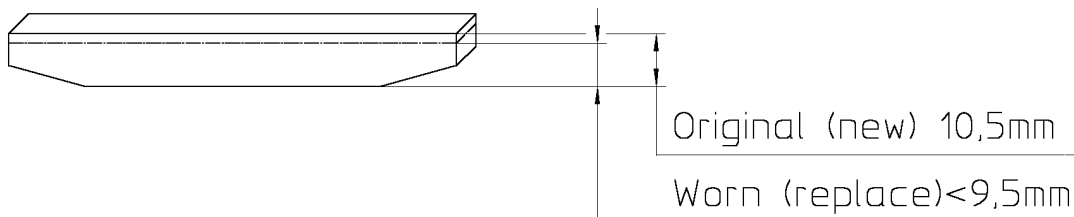

Spare Parts

Only original spare parts may be used. There is no warranty for damages and liability is disclaimed, if non-original spare parts and accessories are used.



Spare Parts List				
Description:			Part and drawing number:	
Pneumatic Sabre Saw			5 1217 0020	
Item	Qty.	Description	Part and drawing number	Remarks
	1	Motor, assy.	5 1217 1000	see extra list from serial no. 231016
	1	Handle, assy.	5 1216 6000	see extra list
	1	Gearbox head	5 1216 4000	see extra list
	1	Performance Kit	5 1217 9990	**
	4	Socket head screw	9 1110 2240	from serial no. 231016
	4	Washer	9 3302 0150	from serial no. 231016
	1	Nipple	9 2205 2360	
	1	Protective cap	9 3401 0970	
	1	Quick-change chuck assy.	5 1217 9300	see extra list from serial no. 231016
	1	Type sign	9 3101 0630	
	2	Round head grooved pin	9 1628 0040	
	1	Warning label	9 3102 0300	
	2	Spitznas logo	9 3107 0080	
	1	Cardboard box	9 9910 0300	
		** Performance Kit 2300	5 1217 9400	

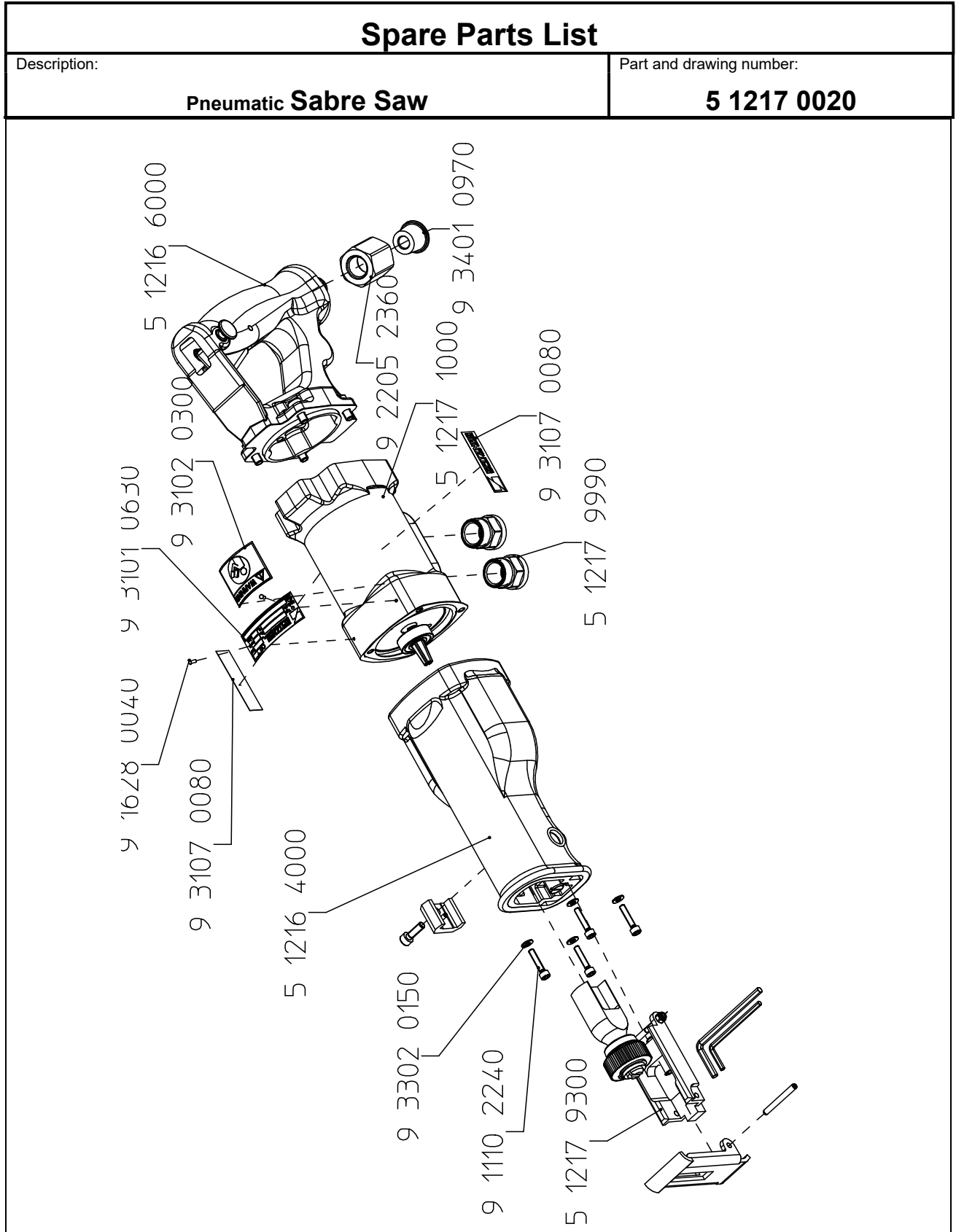

Spare Parts List				
Description:			Part and drawing number:	
Motor			5 1217 1000	
Item	Qty.	Description	Part and drawing number	Remarks
1	1	Motor housing	5 1216 1010	
2	1	Sound absorber pipe	5 1216 1710	from serial no. 231016**
3	1	End plate	1 1430 1110	*
4	1	Grooved ball bearing	9 1003 0010	*
5	1	Snap ring	9 1703 0050	
6	1	Spacer ring	1 1430 1080	*
7	1	Cylinder bushing	5 6030 1020	
8	1	Brace	9 1630 1060	
9	1	Brace	9 1630 1060	
10	1	Rotor	5 1217 1030	up to serial no. 231016
10	1	Rotor	5 1218 1630	from serial no. 231016**
11	3	Vane	5 1216 1050	* **
12	1	End plate	5 6030 1100	*
13	1	Grooved ball bearing	9 1003 0370	*
14	1	Snap ring	9 1703 0070	
15	1	Spacer ring	5 1202 1080	
16	1	O-ring	9 1901 4950	*
17	1	Motor cover	5 1216 1120	
19	1	Sealing	5 1218 4190	*
20	1	Pinion	5 1216 4170	
21	1	Grooved ball bearing	9 1003 0470	*
		* Wear parts to be stored in case of continuous use		
		** Performance Kit 2300	5 1217 9400	

Spare Parts List

Description:

Motor

Part and drawing number:

5 1217 1000

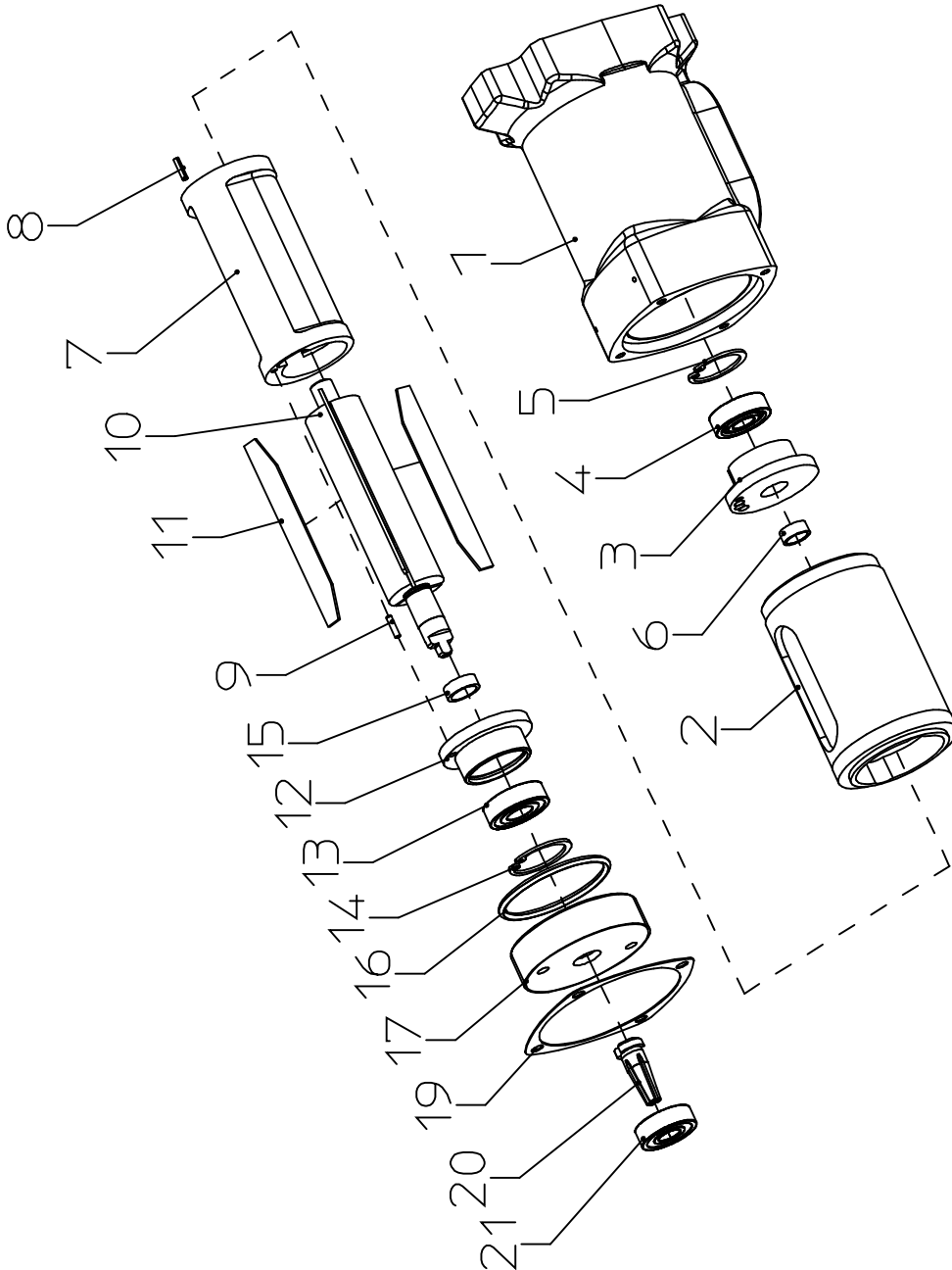



Spare Parts List

Description: Handle			Part and drawing number: 5 1216 6000		
Item	Qty.	Description	Part and drawing number		Remarks
22	1	Handle	5 1216 6010		
23	1	Valve trigger	5 6003 3040		
24	1	Double notched taper pin	9 1641 0020		
25	1	Cylinder pin	5 1216 3190		
26	1	Gasket	9 1903 0160	*	
27	1	Steel ball	9 1017 0080		
28	1	Pressure spring	9 1803 0250		
29	1	Nipple with screen	9 2205 1190		
30	1	O-Ring	9 1901 3230	*	
31	4	Socket head screw	9 1110 4360		
32	1	Bushing	5 1216 3160		
33	1	Guide sleeve	5 1216 3170		
34	1	Pressure spring	9 1803 3360		
35	1	Locking slide	5 1216 3150		
36	1	Lens head screw with cross slot	9 1166 0170		
37	1	Release button	5 1128 3180		
38	1	Threaded pin	9 1140 7700		
39	1	Drill bushing	2 2404 6520		
40	1	Sealing	5 1216 6030		
41	1	Circlip	9 1717 0140		
		* Wear parts to be stored in case of continuous use			

Spare Parts List	
Description:	Part and drawing number:
Handle	5 1216 6000

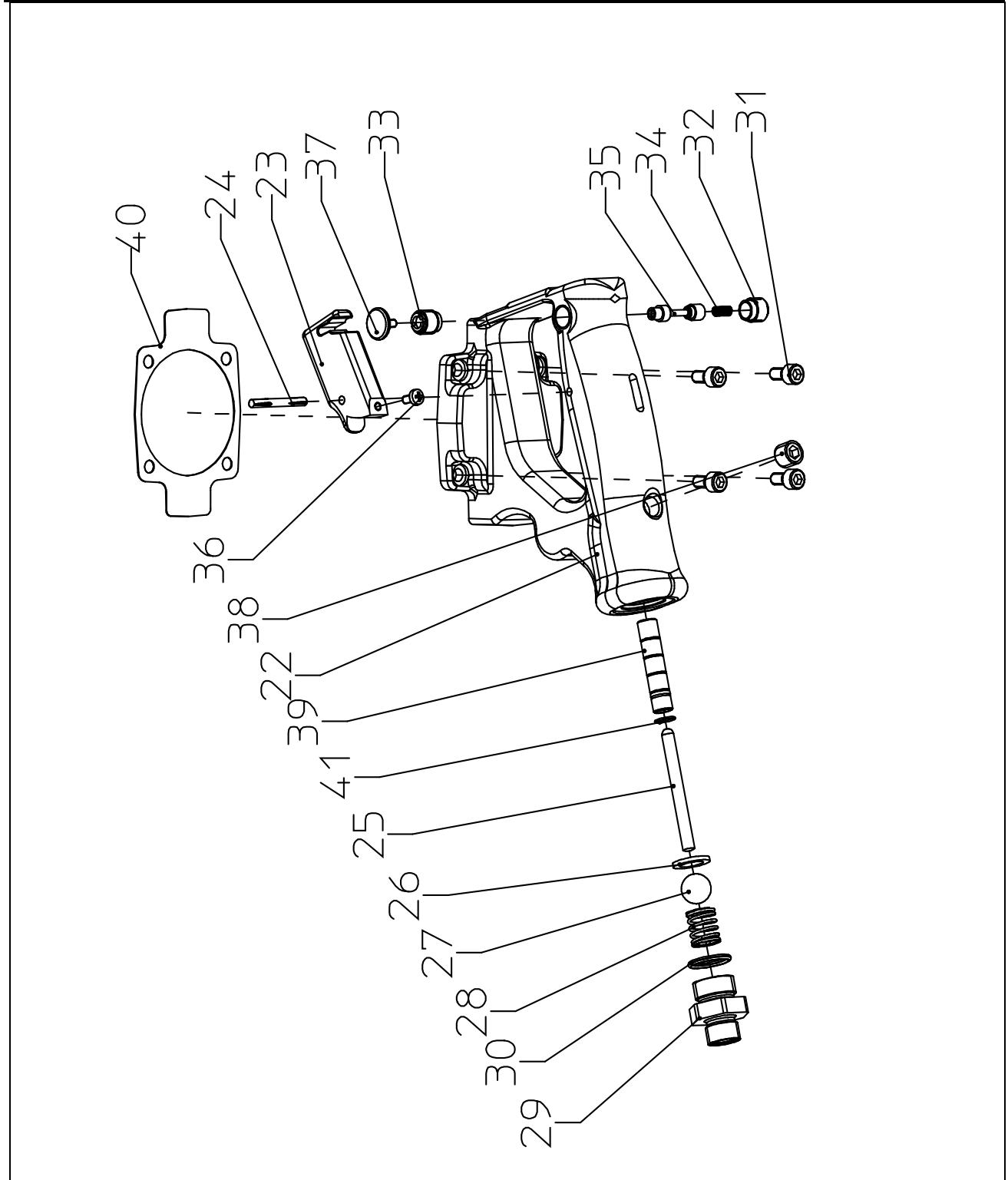

Spare Parts List						
Description:				Part and drawing number:		
Gearbox head				5 1216 4000		
Item	Qty.	Description	Part and drawing number		Remarks	
1	1	Protective cover	5 1216 9010	*		
2	5	Socket head screw	9 1110 3120			
3	1	Saw blade pressure piece, assy.	5 1216 7920		with item 4	
4	1	Spiral pin (centring pin)	9 1642 0220		shorten to 7 mm	
5	1	Lift rod	5 1216 4260			
6	3	Socket head screw	9 1110 1040			
7	1	Gate	5 1216 4310			
8	1	Sealing	5 1216 4320	*		
9	1	Gear part 2	5 1216 4010			
10	2	Cylinder pin	9 1631 0150			
11	1	Needle bearing	9 1013 0450			
13	1	Socket head screw	9 1110 3080			
14	1	Spring pressure piece	9 1810 0080			
15	1	Supporting shoe	5 1216 7070			
16	1	Brace	9 1642 0270			
17	1	Sliding roller	5 1216 4180			
18	1	Pressure spring	9 1803 4360			
19	1	Steel ball	9 1017 0050			
22	1	Bevel gear wheel, assy.	5 1216 4930		with items 23, 24	
23	1	Needle sleeve	9 1014 0230			
25	1	Axial thrust bearing	9 1024 0420			
26	1	Axial disc	9 1024 0410			
27	4	Socket head screw	9 1110 3100			
28	1	Gear part 1	5 1216 4920		with item 30	
29	1	O-ring	9 1921 1430	*		
120	1	Roller guide	5 1216 4370			
122	2	Needle bearing with axle and shaft	5 1216 4970		with items 121, 123	
124	1	Roller holder, assy.	5 1216 4410		Items 121-123	
125	1	External ring	5 1216 4480			
126	1	Needle sleeve	9 1014 0120			
		* Wear parts to be stored in case of continuous use				

Spare Parts List

Description:

Gearbox head

Part and drawing number:

5 1216 4000

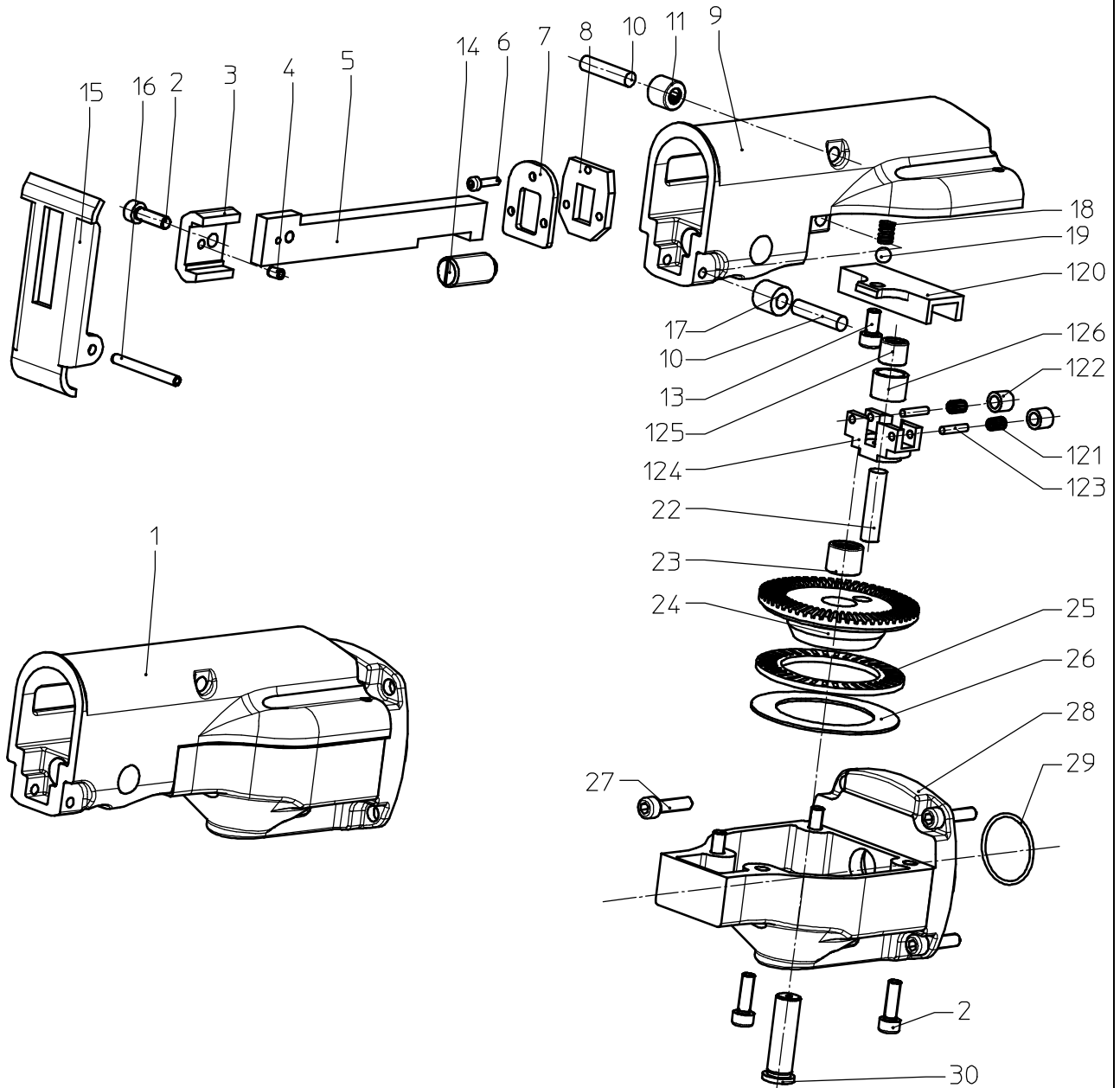

Spare Parts List					
Description:				Part and drawing number:	
Adapter, assy.				5 1217 9300	
Item	Qty.	Description	Part and drawing number		Remarks
	1	Adapter	5 1217 9310		
	1	Threaded pin	9 1140 5050		
	1	Hexagonal nut	9 1209 0150		
	1	Socket head screw	9 1110 2220		
	1	Hexagonal nut	9 1210 0190		
	1	Screw driver hexagonal	9 1314 0090		
	1	Screw driver hexagonal	9 1314 0040		
	1	Adapter	5 1217 9330		
	1	Spring washer	5 1217 9340		
	1	Sleeve	5 1217 9350		
	1	Ring	5 1217 9360		
	1	Bolt	5 1217 9370		
	1	Adjusting ring	5 1217 9380		
	1	Snap ring	9 1702 0110		
	1	Leg spring	9 1807 0360		

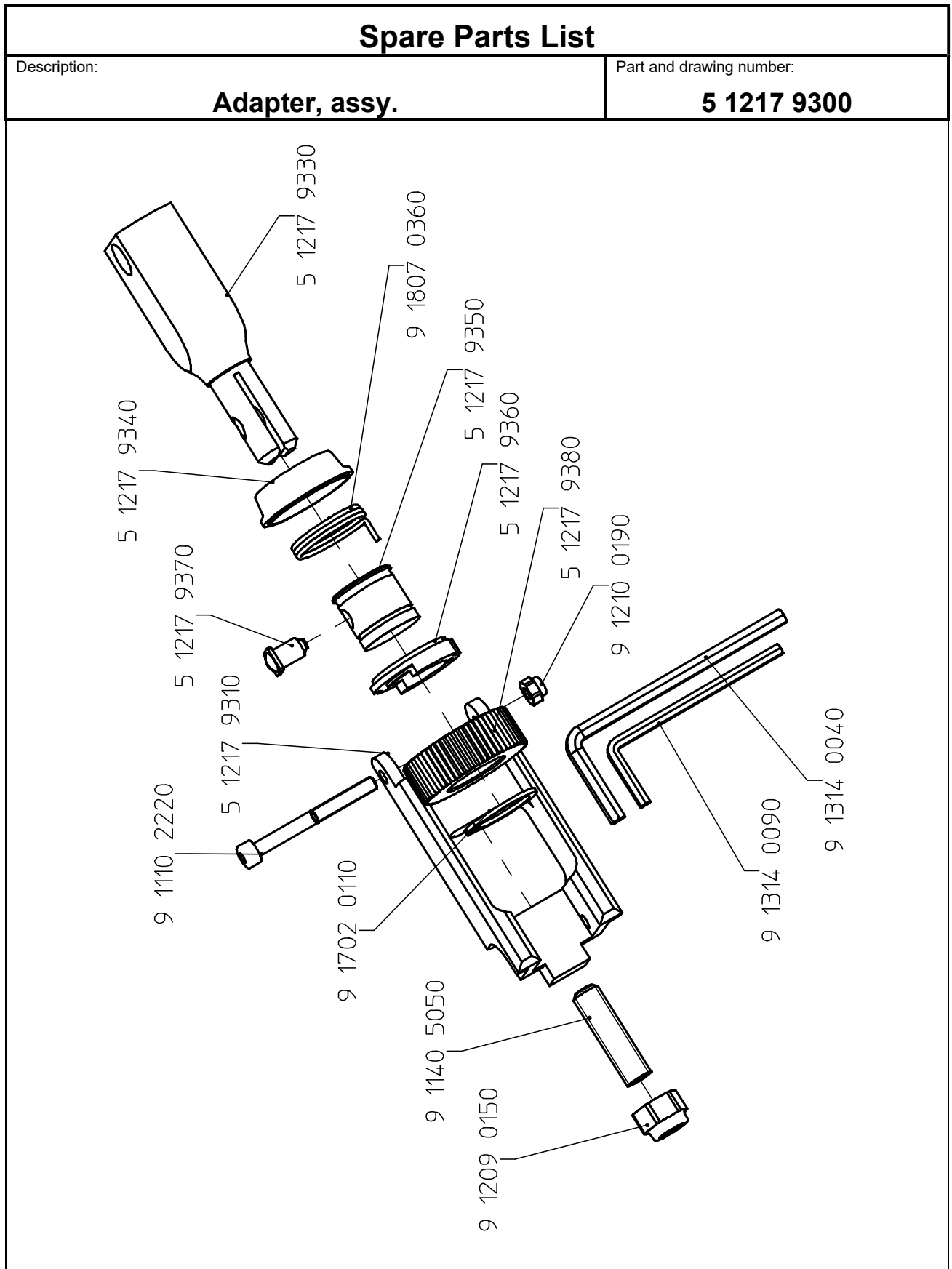

Pneumatic Sabre Saw
5 1217 0020



Note:

Pneumatic Sabre Saw
5 1217 0020



Sketch:



CS Unitec, Inc.
22 Harbor Ave, Norwalk, CT
06850
USA

Toll-free: 1-800-700-5919
(USA & Canada)
Phone: 203-853-9522
(outside USA & Canada)
Fax: 203-853-9921
E-Mail: info@csunitec.com
Internet: www.csunitec.com



Maschinenfabrik GmbH
Fellerstraße 4, 42555 Velbert
Germany

Tel.: +49 2052 605 0
Fax: +49 2052 605 29
E-Mail: spitznas@spitznas.de
www.spitznas.de