

## ESD 162 Dry Core Drill

### NEW Powerful Innovation in Drilling Reinforced Concrete!

- IHT soft impact technology provides faster drilling, reduced heat, extended bit life, & excellent dust extraction.



- Dry drilling up to 8" in brick/ block, 6-3/8" in reinforced concrete.
- New technology to replace the need for water in reinforced concrete; no slurry!
- Can be used for hand or rig-guided drilling .
- Dust extraction system for increased user safety.

*Ergonomic design & anti-vibration handles*



*The ESD 162 comes with the EDMC Pro digital motor control with a service and overload indicator, soft start, & over current cut-off.*

*Kits Available:*

*Anchor Stand Kit: Part No. ESD 162 POSA*



### Specifications

|                    |                                 |
|--------------------|---------------------------------|
| Motor Power        | 19.5 Amp, 110 V                 |
| Load Speeds (RPM)  | 0-1000 RPM                      |
| Drilling Diameter  | 6-3/8" / 8"                     |
| Spindle Connection | 1-1/4" x 7 UNC<br>5/8" x 11 UNC |
| Collar Diameter    | 60 mm                           |
| Weight             | 15 lbs (motor only)             |

## ESD 162 Accessories

Core Bits are a Truly Unique Product, Specially Designed for the ESD 162 Dry Core Drill.

**PB core bits MUST be used when in hammer mode.**

- Optimal results in rebar reinforced concrete, brick, block, & more.
- Maintain high working speeds during extended drilling periods.
- Highly durable diamond segments.
- Extremely cool cutting & superior dust collection.



**BST 162 H Stand**

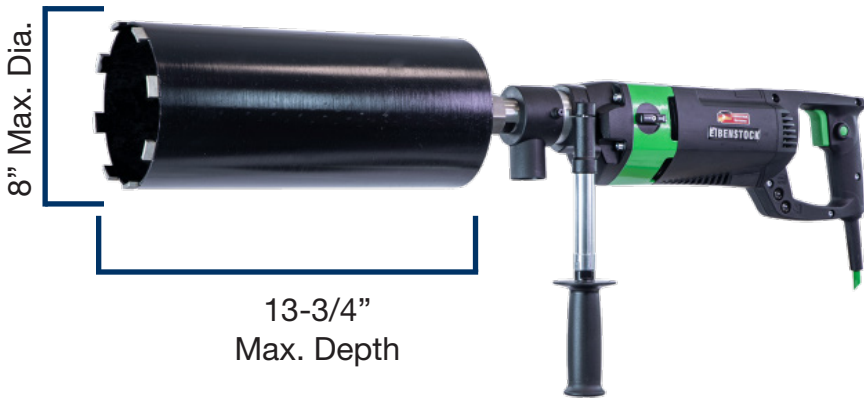

8" Max. Dia.

13-3/4" Max. Depth



*Centering Rod for starting the holes free hand - part no. 36394000*



**Use with CS 1445 H HEPA Vacuum**



*ESD 162 & BST 162 H Stand Kit:  
Part # ESD 162 POSA*

| Part No.  | Diameter |
|-----------|----------|
| PB1341334 | 1-3/4"   |
| PB2001334 | 2"       |
| PB2121334 | 2-1/2"   |
| PB3001334 | 3"       |
| PB3121334 | 3-1/2"   |
| PB4001334 | 4"       |
| PB4121334 | 4-1/2"   |
| PB5001334 | 5"       |
| PB6001334 | 6"       |
| PB6381334 | 6-3/8"   |
| PB7001334 | 7"       |
| PB8001334 | 8"       |

**Distributed By:**



22 Harbor Ave, Norwalk, CT 06850  
 4330 Center St, Deer Park, TX 77536  
 Phone 800-700-5919 • 203-853-9522  
 info@csunitec.com • [www.csunitec.com](http://www.csunitec.com)