

AXIAL PISTON PUMPS

PLASTIC DOSING PUMPS

DRIVES FOR THE SPECIALIST

HYDRAULIC



SYSTEM CONCEPT



Key or spline shaft

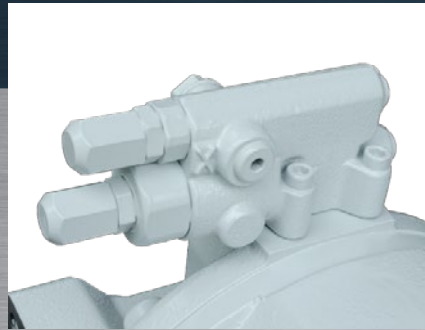

Pressure control valve or
pressure flow control valve



Suction port

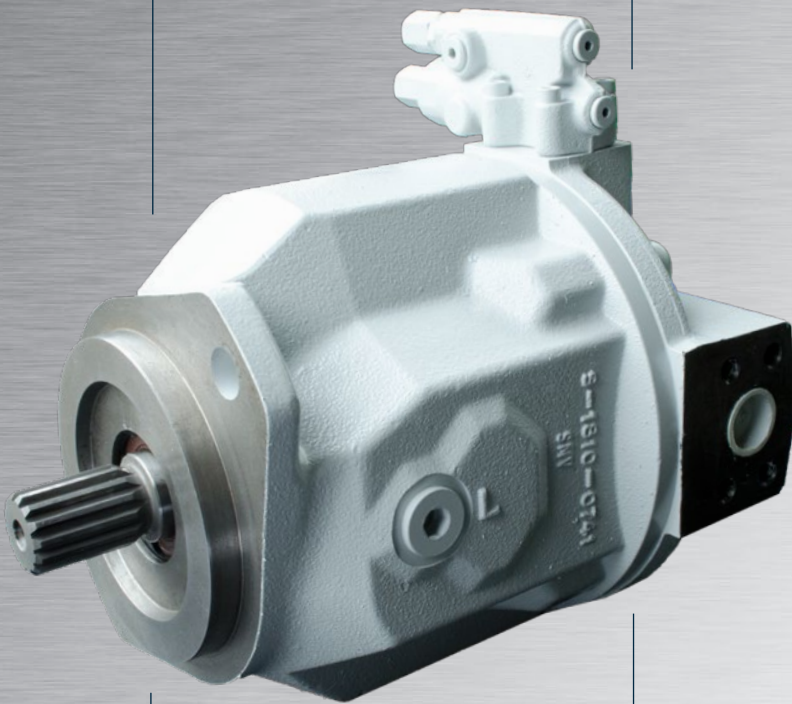

SAE 2-holes mounting flange



1-800-700-5919 (US/CA)

Pressure port



www.csunitec.com
info@csunitec.com

Lecakage port



+1-203-853-9522 (Intl.)

TYPE SVP - SERIES 2

Our hydraulic **axial piston pumps** type **SVP** series 2 for open circuit and an operating pressure up to 280 bar are mainly used in **mobile hydraulic** applications. There are two sizes with 45 ccm and 74 ccm displacement capacity with different types available.



HYDRAULIC



OPERATING PRESSURE 280 Bar

ORDER NO.	Displacement flow	Operating pressure	Max. pressure	Max. Speed at Vg max., 1 bar*	Max. power at delta p=280 bar, at n0 max.	Rotation direction	Shaft type	Mounting thread -at side position-	Control type	Weight (w/o oil filling)
	Vg max. ccm/U	p oper. bar	p max. bar	n0 max. rpm	P max. kW					kg
S-2A11-045R	45	280	350	2,600	55.0	right	SAE 1"	metric	DR ¹⁾	23.0
S-2A12-045R	45	280	350	2,600	55.0	right	SAE 1"	metric	DFR ²⁾	23.0
S-2B11-045R	45	280	350	2,600	55.0	right	SAE 1"	UNC	DR ¹⁾	23.0
S-2B12-045R	45	280	350	2,600	55.0	right	SAE 1"	UNC	DFR ²⁾	23.0
S-2A11-045L	45	280	350	2,600	55.0	left	SAE 1"	metric	DR ¹⁾	23.0
S-2A12-045L	45	280	350	2,600	55.0	left	SAE 1"	metric	DFR ²⁾	23.0
S-2B11-045L	45	280	350	2,600	55.0	left	SAE 1"	UNC	DR ¹⁾	23.0
S-2B12-045L	45	280	350	2,600	55.0	left	SAE 1"	UNC	DFR ²⁾	23.0
S-2A11-074R	74	280	350	2,200	76.0	right	SAE 1 1/4"	metric	DR ¹⁾	34.0
S-2A12-074R	74	280	350	2,200	76.0	right	SAE 1 1/4"	metric	DFR ²⁾	34.0
S-2B11-074R	74	280	350	2,200	76.0	right	SAE 1 1/4"	UNC	DR ¹⁾	34.0
S-2B12-074R	74	280	350	2,200	76.0	right	SAE 1 1/4"	UNC	DFR ²⁾	34.0
S-2A11-074L	74	280	350	2,200	76.0	left	SAE 1 1/4"	metric	DR ¹⁾	34.0
S-2A12-074L	74	280	350	2,200	76.0	left	SAE 1 1/4"	metric	DFR ²⁾	34.0
S-2B11-074L	74	280	350	2,200	76.0	left	SAE 1 1/4"	UNC	DR ¹⁾	34.0
S-2B12-074L	74	280	350	2,200	76.0	left	SAE 1 1/4"	UNC	DFR ²⁾	34.0

Subject to technical change.

*absolute pressure at suction port, min. 0,85 bar

¹⁾DR-pressure control

²⁾DFR-pressure flow control

DISPLACEMENT		45 ccm	74 ccm
Min. inlet pressure (absolut)	Pabs., min.	bar	0.85
Max. inlet pressure (absolut)	Pabs., max.	bar	5.0
Max. drain line pressure (absolut)	PLeck	bar	2,0
Operating temperature	T	°C	-10 bis +90
Operating viscosity	vopt.	mm ² /s	16-32
Viscosity limits, short-time	Vmin./max.	mm ² /s	10-1000
Contamination class			18/45 according to ISO/DIS 4406 9 according to NAS 1638

Subject to technical change.

More types on request.

TECHNICAL DATA

SYSTEM CONCEPT



Key shaft



Leakage port



Hydraulic connection ports

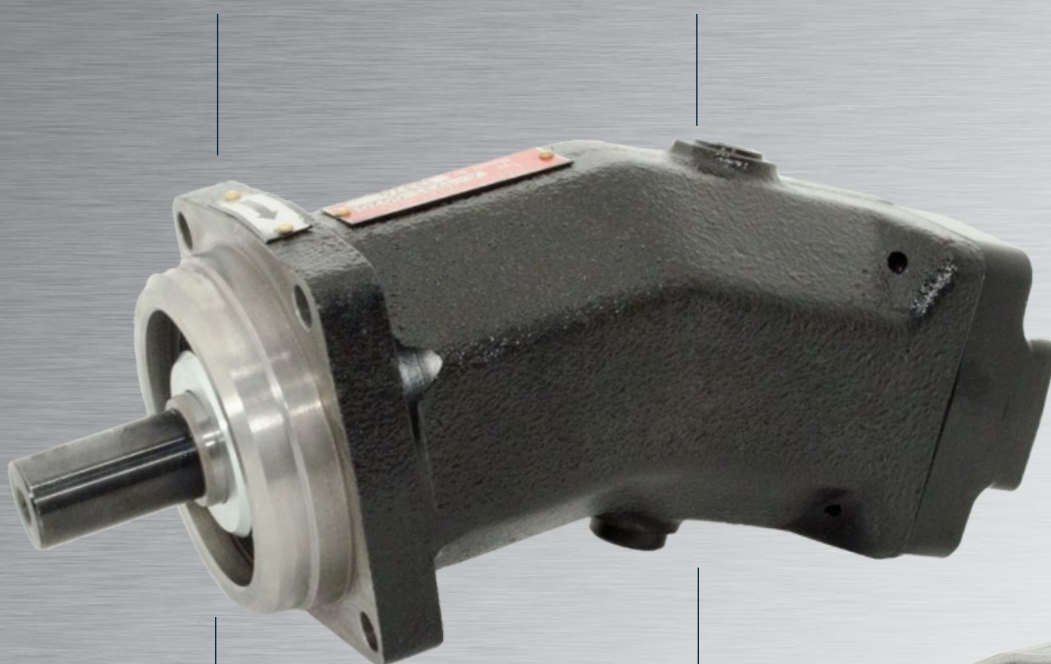

Centering and mounting flange

12,5 or 28,5 ccm/rev. available

Rotation direction right



1-800-700-5919 (US/CA)



www.csunitec.com
info@csunitec.com



+1-203-853-9522 (Intl.)

TYPE KDP - BENT-AXIS TYPE



Our hydraulic **axial piston pumps** type **KDP** for open circuit, are based on bent-axis design. Used as **plastic dosing pumps** they are used up to max. 1,000 mm²/s of material viscosity. Recommended filtration is 100 µm.

HYDRAULIC



OPERATING PRESSURE

250 Bar

ORDER NO.	Displacement flow	Operating pressure	Max. pressure	Operating speed	Max. speed	Power at p oper./ n oper. P oper.	Rotation direction ¹⁾	Min. preload pressure ²⁾ at n max.	Seal material	Type	Weight (w/o Ölfüllung)
	Vg max. ccm/U	p oper. bar	p max. bar	n nenn 1/min	n max. 1/min	kW		bar			kg
A-1931-0020	12.5	250	300	1,450	2,500	8.4	right	1.2-1.5	Viton	brass free	6.8
A-1931-0040*	12.5	250	300	1,450	2,500	8.4	right	1.2-1.5	Viton	brass free	6.8
A-1961-0020	28.5	250	300	1,450	2,500	19.1	right	1.2-1.5	Viton	brass free	12.5

Subject to technical change.

*with double shaft sealing

¹⁾looking at the shaft end, clockwise

²⁾absolute pressure at suction port

DIMENSIONS

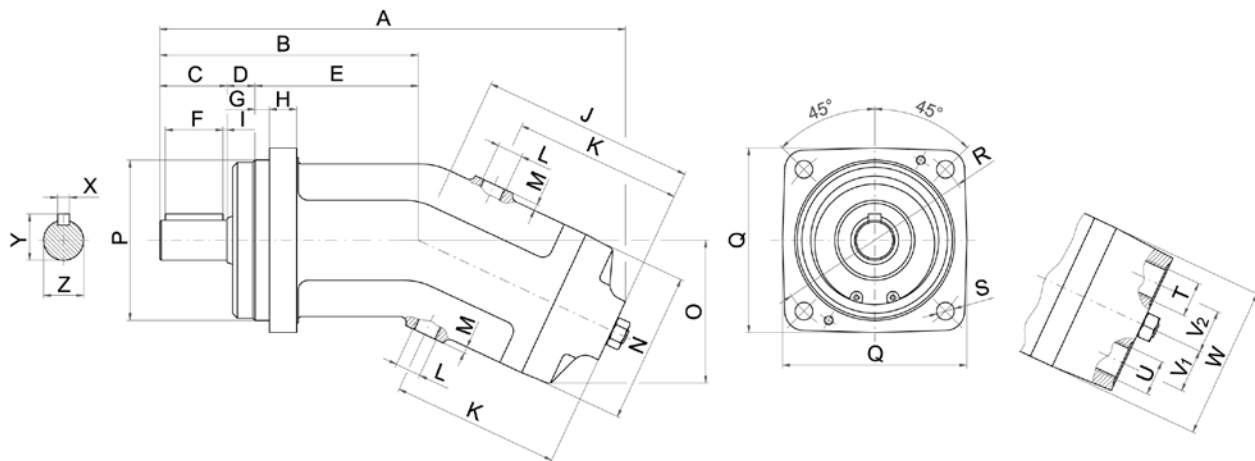

ORDER NO.	A	B	C	D	E	G	H	I	J	K	L	M	N
	mm	mm	mm	mm	mm	mm	mm	mm	mm	mm	mm	mm	mm
A-1931-0020	238	135	36	20	79	7	14	3.0	105	82	M14x1.5	3	80
A-1931-0040	243	140	36	25	79	7	14	3.0	105	82	M14x1.5	3	80
A-1961-0020	300	160	42	25	93	9	17	2.5	133	105	M16x1.5	3	95
ORDER NO.	O	Dia. P f8	Q	Dia. R +/0.2	ØS	T	U	V1	V2	W	X h9	Y	Dia. Z h6
	mm	mm	mm	mm	mm	mm	mm	mm	mm	mm	mm	mm	mm
A-1931-0020	75	80	95	103	9	M22x1.5	M22x1.5	24	24.0	80	6	22.5	20
A-1931-0040	75	80	95	103	9	M22x1.5	M22x1.5	24	24.0	80	6	22.5	20
A-1961-0020	90	100	118	125	11	M27x2	M22x1.5	27	29.5	95	8	27.9	25

More types on request.

TECHNICAL DATA

SYSTEM CONCEPT



Key shaft



Leakage port



Hydraulic connection ports

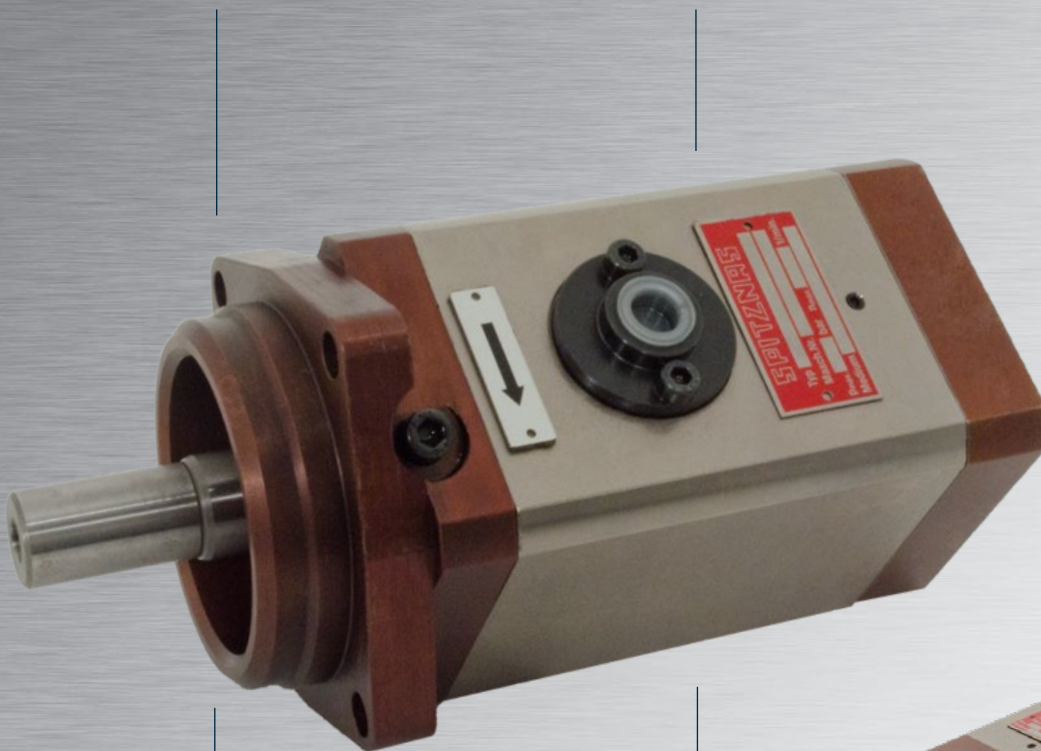

Centering and mounting flange

6,0 , 10,0 or 16,0 ccm/rev available

Rotation direction right



1-800-700-5919 (US/CA)



www.csunitec.com
info@csunitec.com

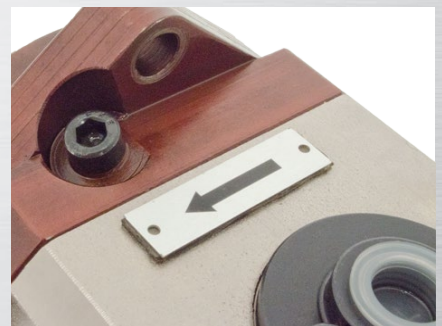

+1-203-853-9522 (Intl.)

TYPE KDP - SWASH PLATE TYPE



Our **hydraulic axial piston pumps** type **KDP** for open circuit, are based on swash plate design. Used as **plastic dosing pumps** they are used up to max. 100 mm²/s of material viscosity. Recommended filtration is 20 µm.

HYDRAULIC



OPERATING PRESSURE 200 Bar

ORDER NO.	Displacement flow	Operating pressure	Max. pressure	Operating speed	Max. speed	Power at p oper./n oper.	Rotation direction ¹⁾	Min. preload pressure ²⁾ at n max.	Seal material	Type	Weight (w/o oil filling)
	Vg max. ccm/U	p oper. bar	p max. bar	n oper. rpm	n max. rpm	P oper. kW		bar			kg
A-1941-6620	6.0	200	250	1,450	2,000	3.2	right	1.2-1.5	Viton	brass free	7.1
A-1941-6060	6.0	200	250	1,450	2,000	3.2	right	1.2-1.5	Viton	brass free	7.4
A-1941-6710	10.0	200	250	1,450	2,000	5.4	right	1.2-1.5	Viton	brass free	7.2
A-1941-7260	16.0	200	250	1,450	2,000	8.6	right	1.2-1.5	Viton	brass free	13.2

Subject to technical change. *with double shaft seal^{ing} ¹⁾looking at the shaft end, clockwise ²⁾absolute pressure at suction port

DIMENSIONS

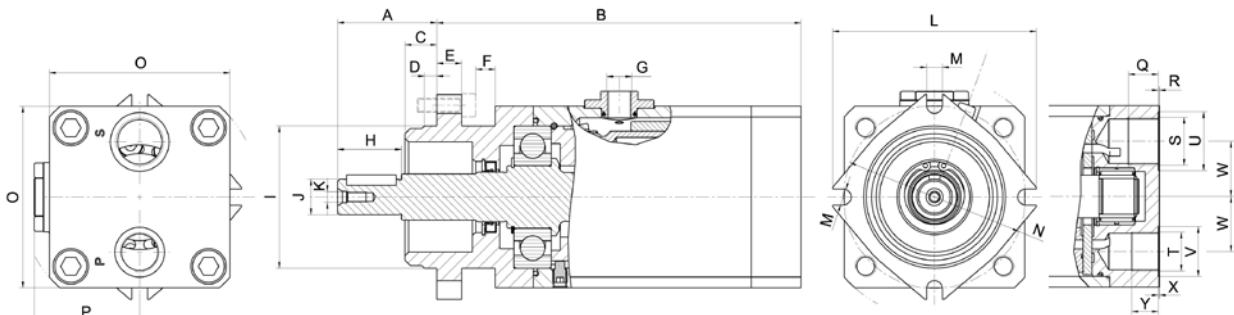

ORDER NO.	A	B	C	D	E	F	G	H	Dia. I f7	Dia. J k6	K	L	Dia. M
	mm	mm	mm	mm	mm	mm	mm	mm	mm	mm	mm	mm	mm
A-1941-6620	56	158.0	18	7	14	-	M14x1.5	36	80	20	M6	119.1	9
A-1941-6060	56	158.0	18	7	14	-	M14x1.5	36	80	20	M6	119.1	9
A-1941-6710	56	158.0	18	7	14	-	M14x1.5	36	80	20	M6	119.1	9
A-1941-7260	56	205.5	18	7	14	11	M14x1.5	36	80	20	M6	115.0	9

ORDER NO.	N	O	P	Q	R	S	T	U	V	W	X	Y
	mm	mm	mm	mm	mm	mm	mm	mm	mm	mm	mm	mm
A-1941-6620	103	80	48.5	15	0.5	M22x1.5	M22x1.5	28	28	25	0.5	15
A-1941-6060	104	80	48.5	15	0.5	M22x1.5	M22x1.5	28	28	25	0.5	15
A-1941-6710	103	80	48.5	15	0.5	M22x1.5	M22x1.5	28	28	25	0.5	15
A-1941-7260	103	102	59.5	17	0.5	M27x2	M22x1.5	33	28	31	0.5	15

More types on request.

TECHNICAL DATA

DESIGN AND FEATURES

DESIGN AND FEATURES - SVP-PUMPS

Our hydraulic **axial piston pumps** of type **SVP** are based on a swash plate design and are made for open circuit.
The oil flow is proportional to speed and displacement which can be adjusted continuously.



- FOR OPEN CIRCUIT
- OPERATING PRESSURE 280 BAR
- ROTATION DIRECTION RIGHT
- FOR MOBILE APPLICATIONS
- MOUNTING FLANGES ACCORDING TO SAE
- VARIABLE DISPLACEMENT
- SHORT RESPONSE TIME
- LONG LIFETIME
- WIDE SPEED RANGE
- LOW NOISE LEVEL

DESIGN AND FEATURES - KDP-PUMPS

Our hydraulic **axial piston pumps** of type **KDP** are based on swash plate design or bent-axis design and are made for open circuit.
The pumps are used for mixing and dosing machines in plastics-processing plants. The oil flow is proportional to speed.



- FOR OPEN CIRCUIT
- OPERATING PRESSURE 200/250 BAR
- FIXED DISPLACEMENT
- ROTATION DIRECTION RIGHT
(looking at the shaft end, clockwise)
- MINIMUM SPEED FROM 20 rpm (swash plate type)
MINIMUM SPEED FROM 80 1/min (bent-axis type)
(depending on viscosity of medium)
- LOW FLOW PULSATION
- MEDIUM-COMPATIBILITY
(based on specially selected materials)
- LOW FLOW PULSATION
- LOW NOISE LEVEL
- OPTIMAL VOLUMETRICAL EFFICIENCY
- OPTIMIZED FOR SERVICE

APPLICATION AREAS:

- Wind energy
- Ship building
- Aircraft construction
- Reconstruction
- Surface protection
- Wear protection
- Insulation
- Pipe coating

CAN BE USED FOR (f.e.):

- Mineral oil
- Epoxy resin
- Polyurethane
- Hybrid plastics
- Polyurea with drop time of less than 15 seconds (reaction time)

HYDRAULIC DRIVES RANGE

HYDRAULIC AXIAL PISTON PUMPS



HYDRAULIC RADIAL PISTON MOTORS



HYDROSTATIC COMPACT DRIVES

