

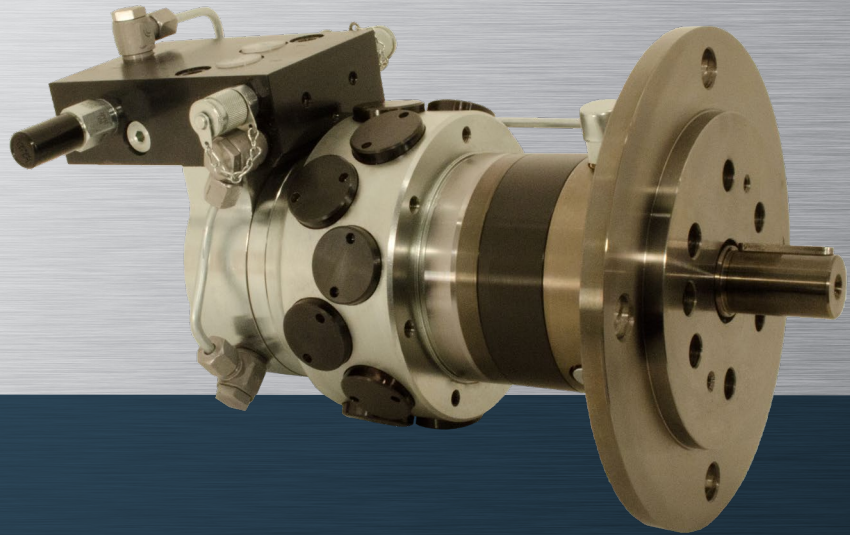

POWERED BY

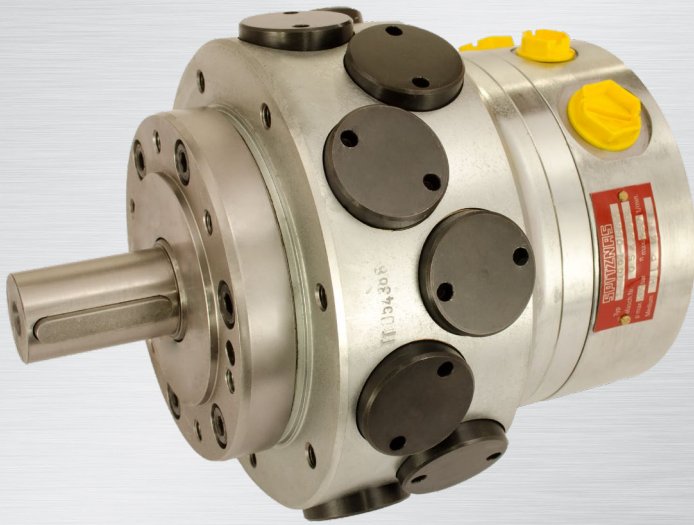

SPITZNAS
CUSTOMIZED POWER SOLUTIONS



RADIAL PISTON MOTORS

DRIVES FOR THE SPECIALIST

HYDRAULIC



ATEX



SYSTEM CONCEPT



Key shaft, spline shaft, or special shaft design on request



Radial or axial hydraulic connection



Optional with control and integrated pressure protection

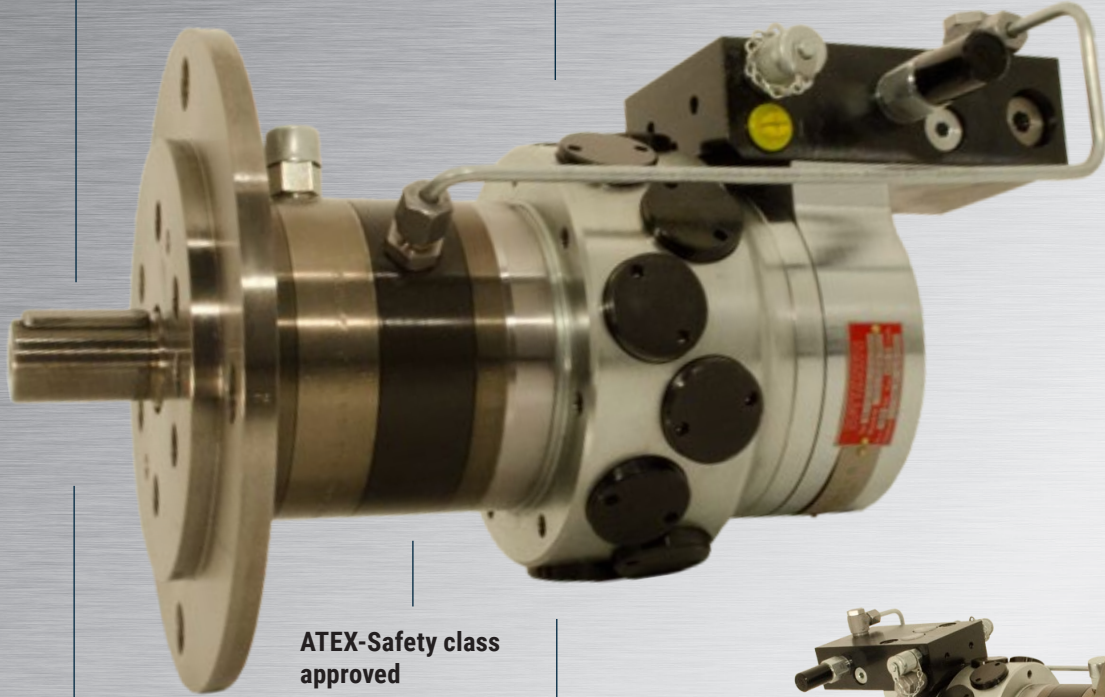

ATEX-Safety class approved

Optional with mit spring preloaded multi-disc brake and/or planetary gear



1-800-700-5919 (US/CA)

Spotface connection or optional mounting flange connection



www.csunitec.com
info@csunitec.com

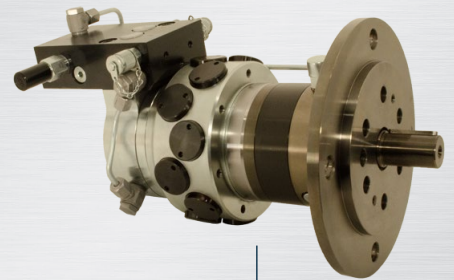

Customer designs

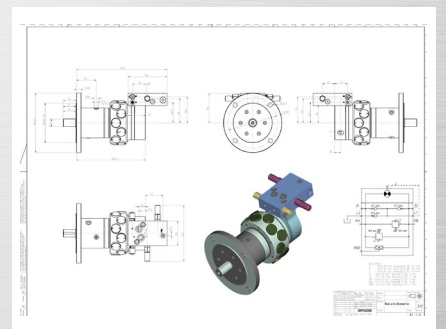

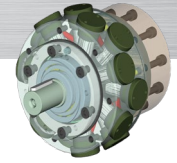

+1-203-853-9522 (Intl.)

TYPE SFM - SERIES 1



Our solid hydraulic radial piston motors of type SFM series 1 are from 12 ccm up to 110 ccm volume flow available. Different types are available.



ORDER NO.	ATEX Specification	Geometrical capacity ccm/U	HYDRAULIC 			OPERATING PRESSURE 160/140 Bar		Sealing material	Shaft type	ATEX 	Connection	Weight kg
			Operating pressure bar	Max. pressure bar	Max. speed rpm	Specific torque Nm/bar						
R-1001-0120	IM2ExhIMbT6	12	160	315	850/1,300*	0.20	NBR	key shaft	G 1/2" female radial	12.5		
R-1A42-0120	IM2ExhIMbT6	12	160	315	850/1,300*	0.20	VITON	spline shaft	G 3/4" female axial	12.5		
R-1001-0220	IM2ExhIMbT6	22	160	315	850/1,500*	0.35	NBR	key shaft	G 1/2" female radial	17.8		
R-1A42-0220	IM2ExhIMbT6	22	160	315	850/1,500*	0.35	VITON	spline shaft	G 3/4" female axial	17.8		
R-1001-0330	IM2ExhIMbT6	33	160	315	850/1,500*	0.52	NBR	key shaft	G 1/2" female radial	18.0		
R-1A42-0330	IM2ExhIMbT6	33	160	315	850/1,500*	0.52	VITON	spline shaft	G 3/4" female axial	18.0		
R-1001-0440	IM2ExhIMbT6	44	160	315	850/1,200*	0.69	NBR	key shaft	G 1/2" female radial	19.0		
R-1A42-0440	IM2ExhIMbT6	44	160	315	850/1,200*	0.69	VITON	spline shaft	G 3/4" female axial	19.0		
R-1001-0660	IM2ExhIMbT6	66	160	315	850/1,200*	1.00	NBR	key shaft	G 1/2" female radial	19.2		
R-1A42-0660	IM2ExhIMbT6	66	160	315	850/1,200*	1.00	VITON	spline shaft	G 3/4" female axial	19.2		
R-1001-0890	IM2ExhIMbT6	89	140	250	550/900*	1.40	NBR	key shaft	G 1/2" female radial	22.0		
R-1A42-0890	IM2ExhIMbT6	89	140	250	550/900*	1.40	VITON	spline shaft	G 3/4" female axial	22.0		
R-1001-1100	IM2ExhIMbT6	110	140	250	450/750*	1.80	NBR	key shaft	G 1/2" female radial	22.2		
R-1A42-1100	IM2ExhIMbT6	110	140	250	450/750*	1.80	VITON	spline shaft	G 3/4" female axial	22.2		

Subject to technical change. * high speed type Performance data at an operating pressure of 140/160 bar.

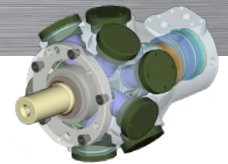
TYPE SFM - SERIES 2



Our solid hydraulic radial piston motors of type SFM series 2 are from 85 ccm up to 255 ccm volume flow available. Different types are available.

ORDER NO.	ATEX Specification	Geometrical capacity ccm/U	HYDRAULIC 			OPERATING PRESSURE 200/250 Bar		Sealing material	Shaft type	ATEX 	Connection	Weight kg
			Operating pressure bar	Max. pressure bar	Max. speed rpm	Spezific torque Nm/bar						
R-2001-0850	IM2ExhIMbT6	85	250	400	800	1.30	NBR	key shaft	flange	42.0		
R-2A43-0850	IM2ExhIMbT6	85	250	400	800	1.30	VITON	spline shaft	internal thread	42.0		
R-2001-1300	IM2ExhIMbT6	130	200	350	600	2.00	NBR	key shaft	flange	42.0		
R-2A43-1300	IM2ExhIMbT6	130	200	350	600	2.00	VITON	spline shaft	internal thread	42.0		
R-2001-1650	IM2ExhIMbT6	165	250	400	800	2.60	NBR	key shaft	flange	60.0		
R-2A43-1650	IM2ExhIMbT6	165	250	400	800	2.60	VITON	spline shaft	internal thread	60.0		
R-2001-2550	IM2ExhIMbT6	255	200	350	600	4.00	NBR	key shaft	flange	60.0		
R-2A43-2550	IM2ExhIMbT6	255	200	350	600	4.00	VITON	spline shaft	internal thread	60.0		

Subject to technical change. Performance data at an operating pressure of 200/250 bar.

TECHNICAL DATA

DESIGN AND FEATURES

DESIGN AND FEATURES

Our hydraulic radial piston motors Type SFM Series 1 and 2 are based on the principle of externally pressured motors with revolving valve and are used in stationary and mobile applications.

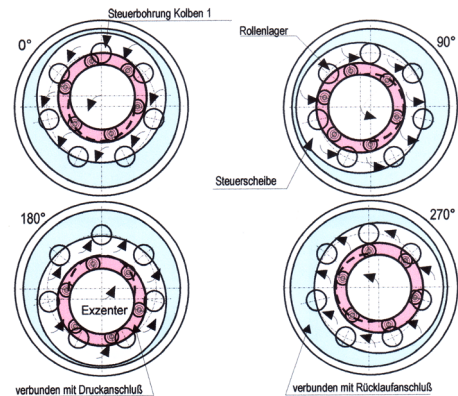
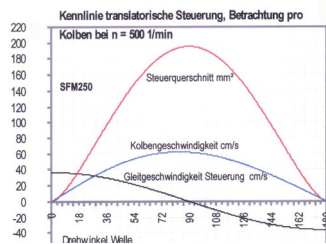

● HIGH ACCURACY CONTROL SYSTEM

The control cross sections are opened and closed within a rotation angle of 180°. Thus, the control cross section refers clearly to the rotation angle of the motor shaft. High spots of compression and decompression are reduced.

● LONG SERVICE LIFE

Service life is optimized by constant internal wear of the translational control (same speed at all points of the control disc surface).

● SELF CLEANING EFFECT

Particles are not sucked into the sealing gap of the sliding surfaces, but they are repelled by the sealing edges.

● HIGH UNIFORMITY

Maximum uniformity based on optimum control adjustments up to 97,5%.

● HIGH TEMPERATURE SHOCK RESISTANT

Automatic balance of pressure and temperature influences, which is controlled by spring preloaded pressure of the pressure regulating device.

● ROTARY GROUP BEARINGS

High quality preloaded roller bearings for heavy duty applications in X-setup allow high axial and radial forces.

● HIGH EFFICIENCY

Volumetric efficiency up to 99% and mechanical efficiency up to 95%.

● HYDROSTATIC BALANCE

Hydrostatic discharge of the pistons ensures optimal protection against wear of the radial piston motor.

● PRESSURE LIQUID MEDIUMS

The motors can be modified for HF-emulsions (on request).

● OPTIONS

Models incl. measuring shaft, rev. transmitter, modular control valve block, brakes, gear boxes and more.

HYDRAULIC DRIVES PROGRAM

HYDRAULIC AXIAL PISTON PUMPS



HYDRAULIC RADIAL PISTON MOTORS



HYDROSTATIC COMPACT DRIVES



CS Unitec | 22 Harbor Ave, Norwalk CT, 06850 | 4330 Center St.
Deer Park, TX 77536 Tel: 203-853-9522 | TF 800-700-5919
E-Mail: info@csunitec.com | www.csunitec.com